



# STAR WARS



9675



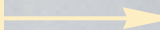
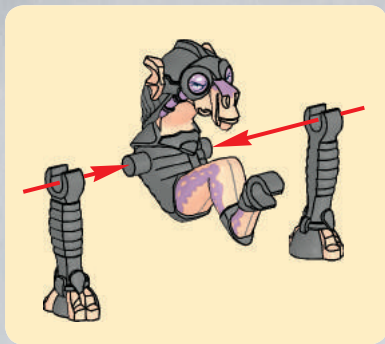

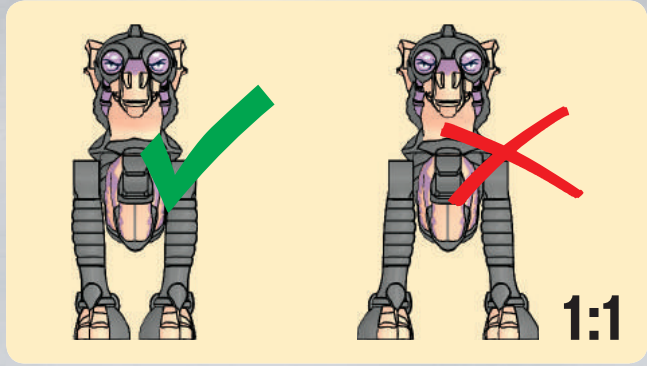

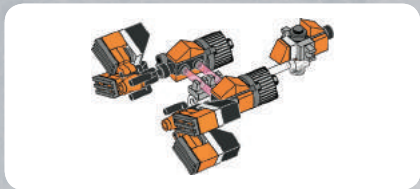

1

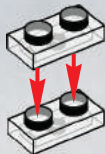

4

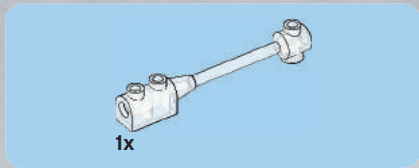

2

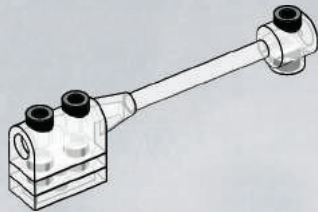

2x

3

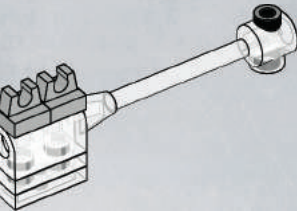

5

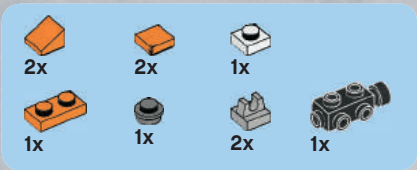

4

1

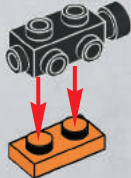

2

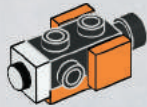

3

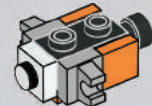

4

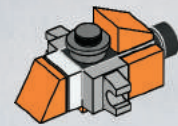

6

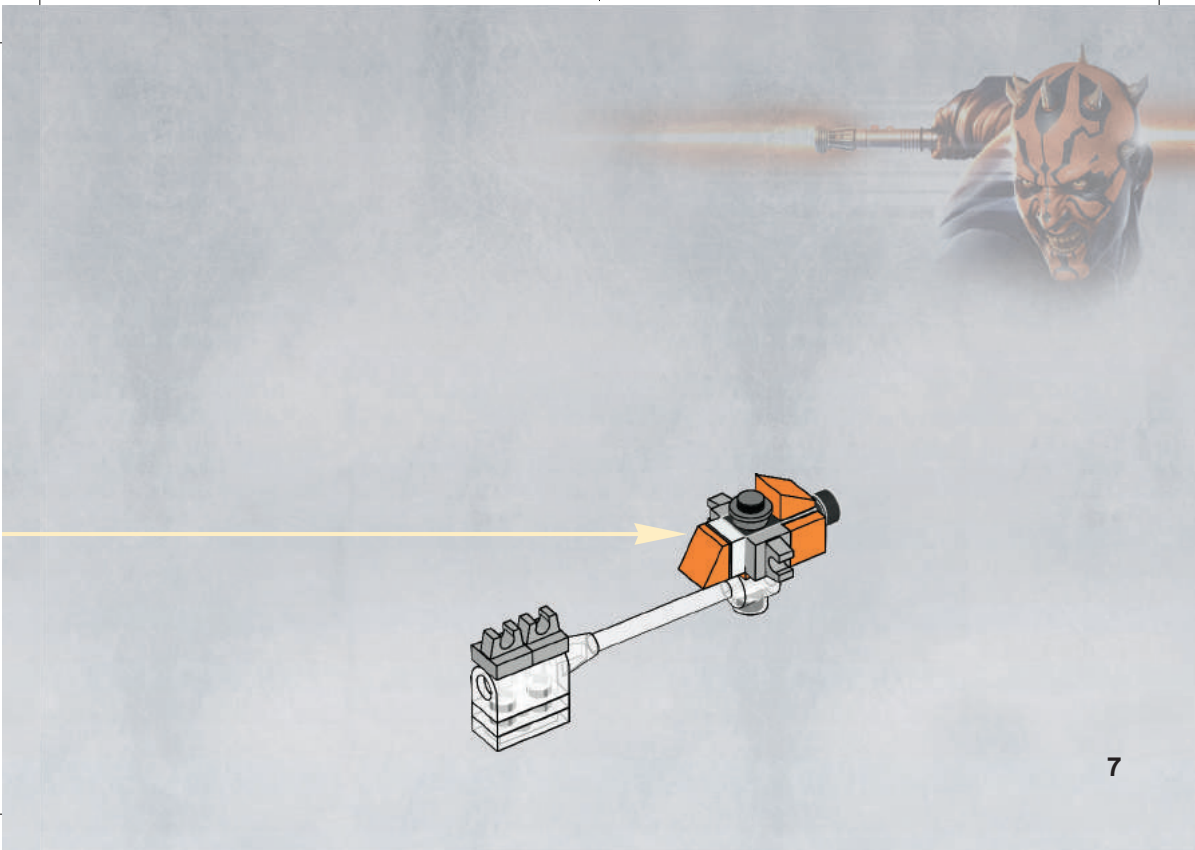

7





1x



1x

1

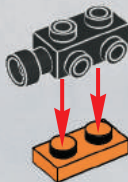

8



2x

2

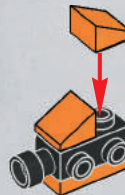



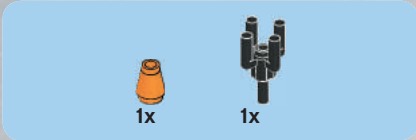

3

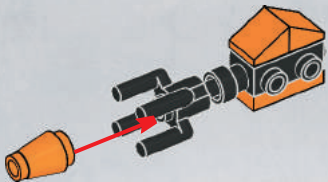

2x

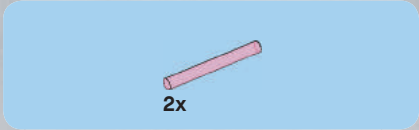

4

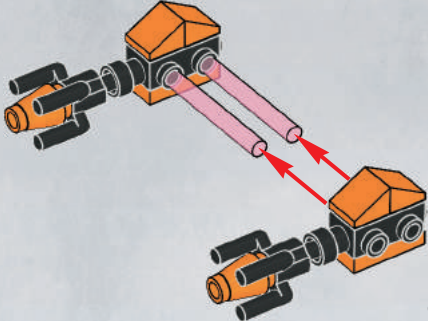

9



5

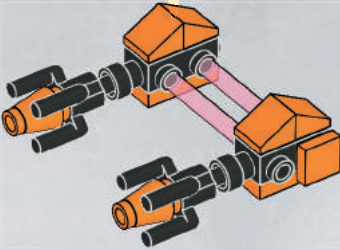

10



6

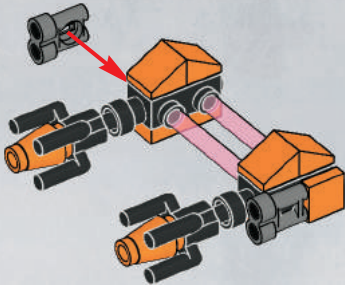

7

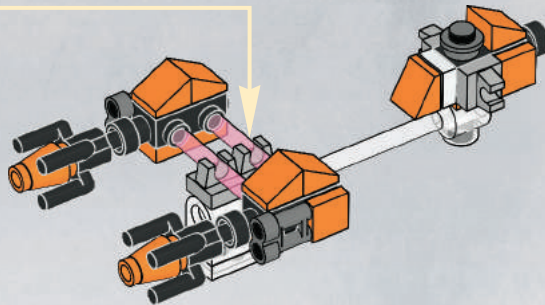

12



1x



1x

1

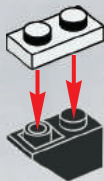

1x



1x

2



13



2x

3

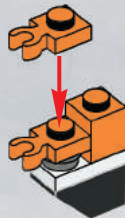

14



1x

4



4x

8

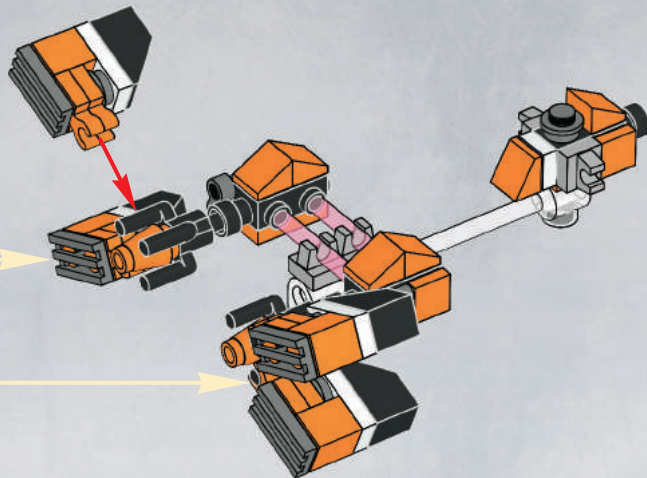

15



2x



2x

# 9

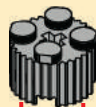

2x

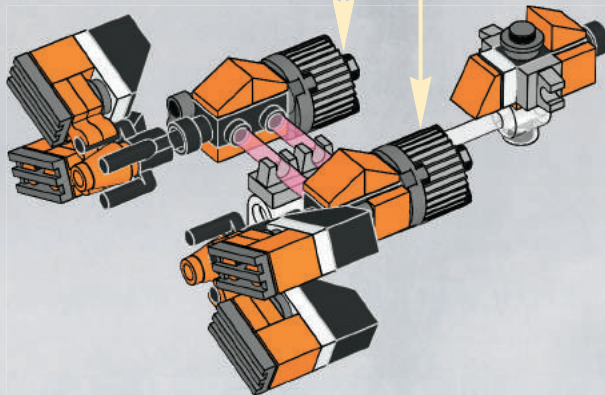

16



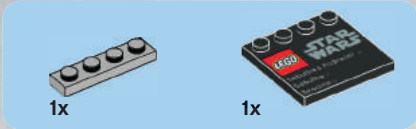

1

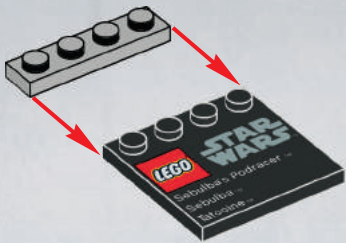

2



17

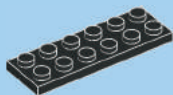

1x

3



18



4

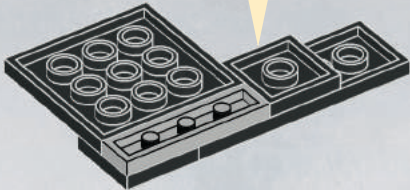
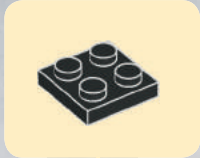

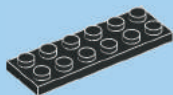

1x

5



20



6

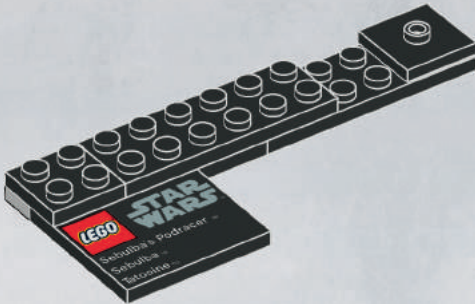



1x

7

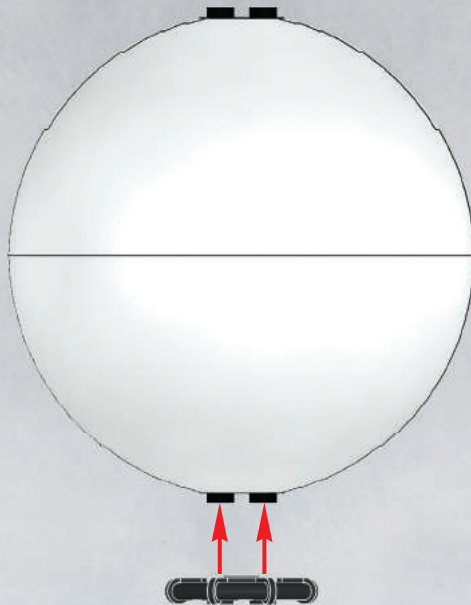

22

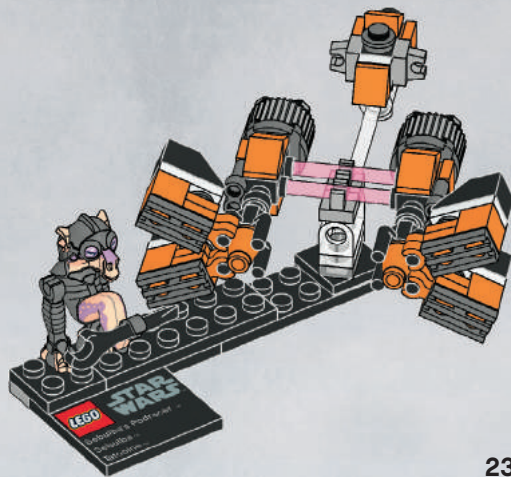

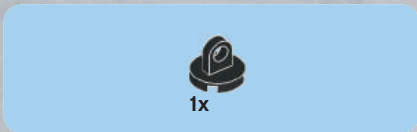

8

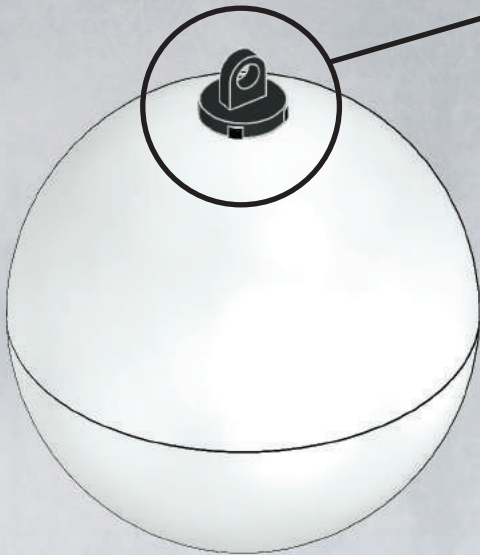

24





1x  
302401



4x  
302301



4x  
4210631



5x  
4210633



2x  
4211042



1x  
4622289



2x  
4622290



2x  
4211051



8x  
4587052



2x  
4655286



2x  
4167842



1x  
4164065



2x  
4650645



1x  
4211445



4x  
4211369



1x  
400626



2x  
4532220



4x  
4173805



2x  
4518029



6x  
4504371



3x  
4177932



4x  
4558595



1x  
4514342



1x  
237626



2x  
379526



1x  
4655294



3x  
4523339



4x  
366526



1x  
4565323



2x  
302226



**Customer Service**

**Kundenservice**

**Service Consommateurs**

**Servicio Al Consumidor**

**www.lego.com/service or dial**



**: 00800 5346 5555**

**: 1-800-422-5346**



9493



9492



9491



9490



9489



9488





9488



9489



9490



9491



9492



9493



9488



9489



9490



9491



9492



9493



9488



9489



9490



9491



9492



9493



9488



9489



9490



9491



9492



9493

# ACE ASSAULT II

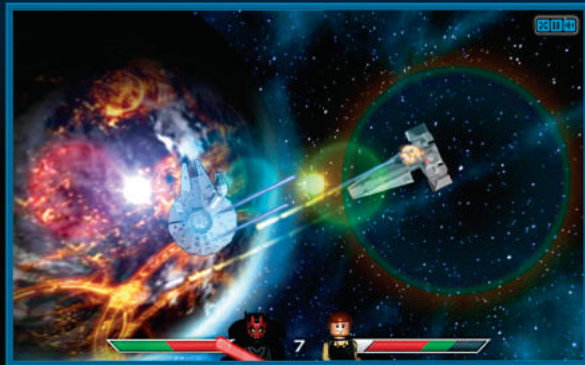

[starwars.LEGO.com](http://starwars.LEGO.com)



# STAR WARS III

THE CLONE WARS™



www.legogames.com  
www.LucasArts.com



LucasArts and the LucasArts logo are registered trademarks of Lucasfilm Ltd. © 2005-2010 Lucasfilm Entertainment Company Ltd. or Lucasfilm Ltd. & ® or TM as indicated.  
All rights reserved. LEGO, the LEGO logo and the Minifigure are trademarks of The LEGO Group. © 2005-2010 The LEGO Group. All rights reserved.



# STAR WARS™

## BATTLE OF HOTH™



© 2012 Lucasfilm Ltd. & TM. All rights reserved.



3866  
Star Wars  
**8+** 2/4 ⏳ 10-20





www.LEGOclub.com



LEGO® Club Email

**LEGO club**™

**FREE! GRATIS! GRATUIT!**



**LEGO® Club Magazine**

**SIGN UP ONLINE!**

**www.LEGOclub.com**

**00800 5346 5555\***



**1-866-534-6258 • 1-877-518-5346**

US & Canada only

Canada seulement

BI110

- \* Freephone. Mobile charges may apply.
- \* Numéro sans frais. Des frais peuvent s'appliquer avec les téléphones cellulaires.
- \* Gebührenfrei, Kosten für Anrufe aus Mobilfunknetzen können abweichen.
- \* Gratis telefoonnummer vanaf vaste lijn.
- \* Det er et gratis nummer, når du ringer fra fasttelefon.
- \* Det är gratis, när du ringer från en fast telefon.
- \* Numéro sans frais. Des frais peuvent s'appliquer avec les téléphones portables.





# WIN!

Go to [www.LEGOsurvey.com/product](http://www.LEGOsurvey.com/product) to fill out a survey for a chance to win a cool LEGO® Product. No purchase necessary. Open to all residents where not prohibited.



[www.LEGO.com](http://www.LEGO.com)

## [www.LEGOsurvey.com/product](http://www.LEGOsurvey.com/product)

### GEWINNE!

Nimm an der Umfrage auf [www.LEGOsurvey.com/product](http://www.LEGOsurvey.com/product) teil und hab die Chance ein cooles LEGO® Produkt zu gewinnen! Die Teilnahme am Gewinnspiel führt zu keinerlei Kaufverpflichtungen. Teilnahme in allen nicht ausgeschlossenen Ländern möglich.

### WIN!

Ga naar [www.LEGOsurvey.com/product](http://www.LEGOsurvey.com/product), vul een enquêteformulier in en maak kans op een cool LEGO® product. Geen aankoopverplichting, iedereen mag deelnemen, uitgezonderd ingezetenden van landen waar een enquêteverbod geldt.

### GAGNE!

Visite [www.LEGOsurvey.com/product](http://www.LEGOsurvey.com/product) pour répondre à un questionnaire et avoir une chance de gagner un produit LEGO® très cool ! Aucune obligation d'achat. Ouvert à tous les résidents des pays autorisés.

### 当てよう!

[www.LEGOsurvey.com/product](http://www.LEGOsurvey.com/product) にアクセスして、アンケートにご記入ください。当選者にはレゴ製品を差し上げます。お買い上げの必要はありません。禁止されていない限り、すべての皆様にご利用いただけます。

6003447

LEGO and the LEGO logo are trademarks of the LEGO Group. ©2012 The LEGO Group. © 2012 Lucasfilm Ltd. & TM. All rights reserved.

