



STAR WARS

ULTIMATE COLLECTOR SERIES



75181

Booklet available in English on
Heft in deutscher Sprache erhältlich auf
Livret disponible en français sur
Libretto disponibile in Italiano su
Folleto disponible en español en
Folheto disponível em português em
A füzet magyarul ezen a honlapon olvasható:
Buklets latviešu valodā pieejams vietnē
如需中文版手册, 请访问

LEGO.com/starwars



“WE’RE STARTING OUR ATTACK RUN!”



Design Director: Jens Kronvold Frederiksen / Model Designer: Jordan David Scott / Graphic Designer: Madison O'Neil

ABOUT THE LEGO® STAR WARS DESIGN TEAM

LEGO® *Star Wars* started in 1999 and we have made new models for the product line every year since then. The LEGO *Star Wars* design team consists of eleven model designers and four graphic designers. The team is a mix of brand new designers with new fresh ideas, and experienced LEGO *Star Wars* designers with many models under their belts.

This is an ideal team for creating new, innovative LEGO *Star Wars* models, as well as revising and improving previous LEGO versions of classic and iconic *Star Wars* ships. The focus of our main LEGO *Star Wars* product line is to make cool, fun and inspiring LEGO *Star Wars* models for children.

For LEGO Direct, we have the opportunity to make even bigger, more challenging models with special attention to accuracy and details. These models are fun and exciting to develop, but also a huge challenge! We always do our very best, and hope you will enjoy building it.

Happy building!



Jens Kronvold Frederiksen
Design Director, LEGO® *Star Wars*™

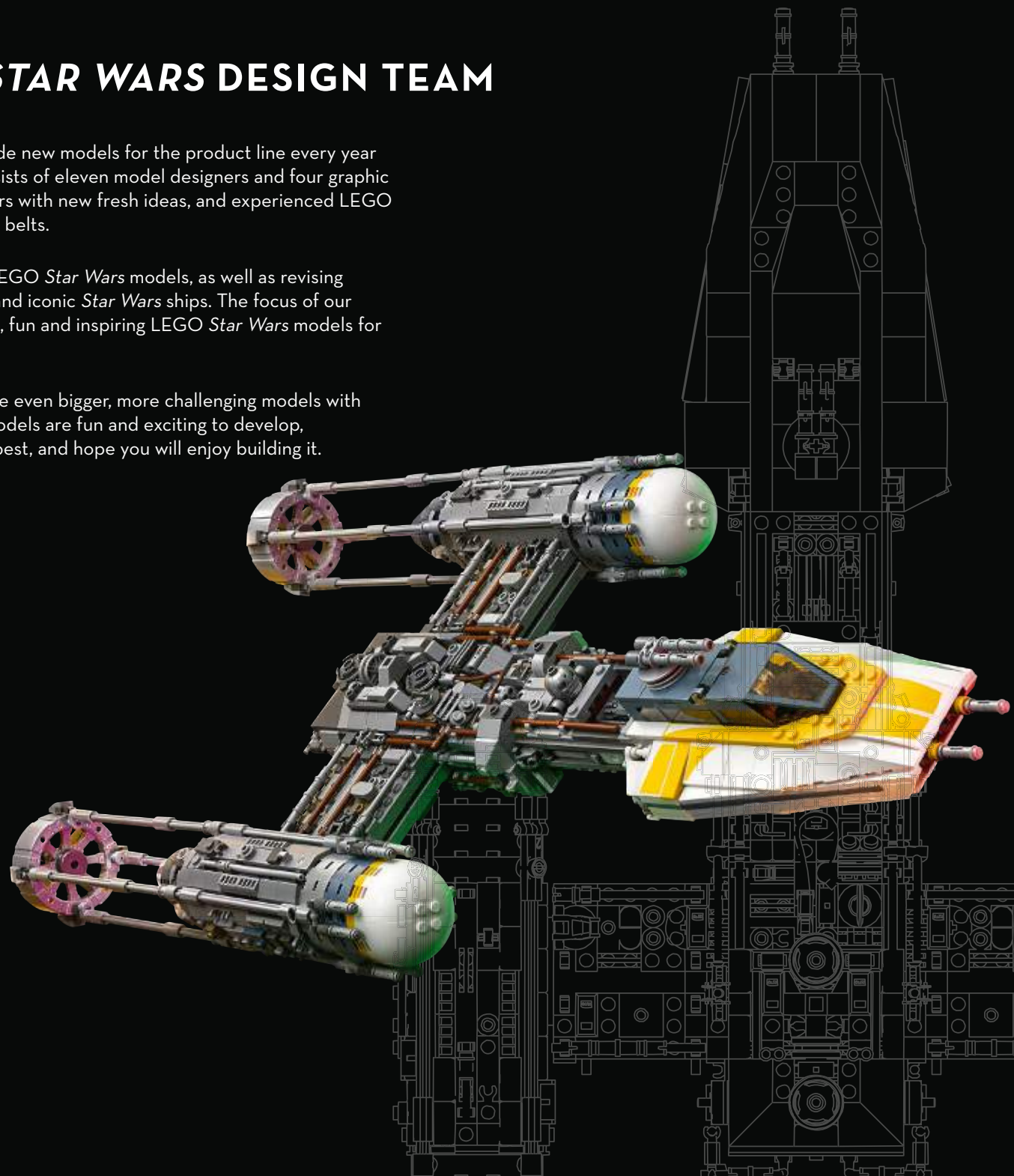

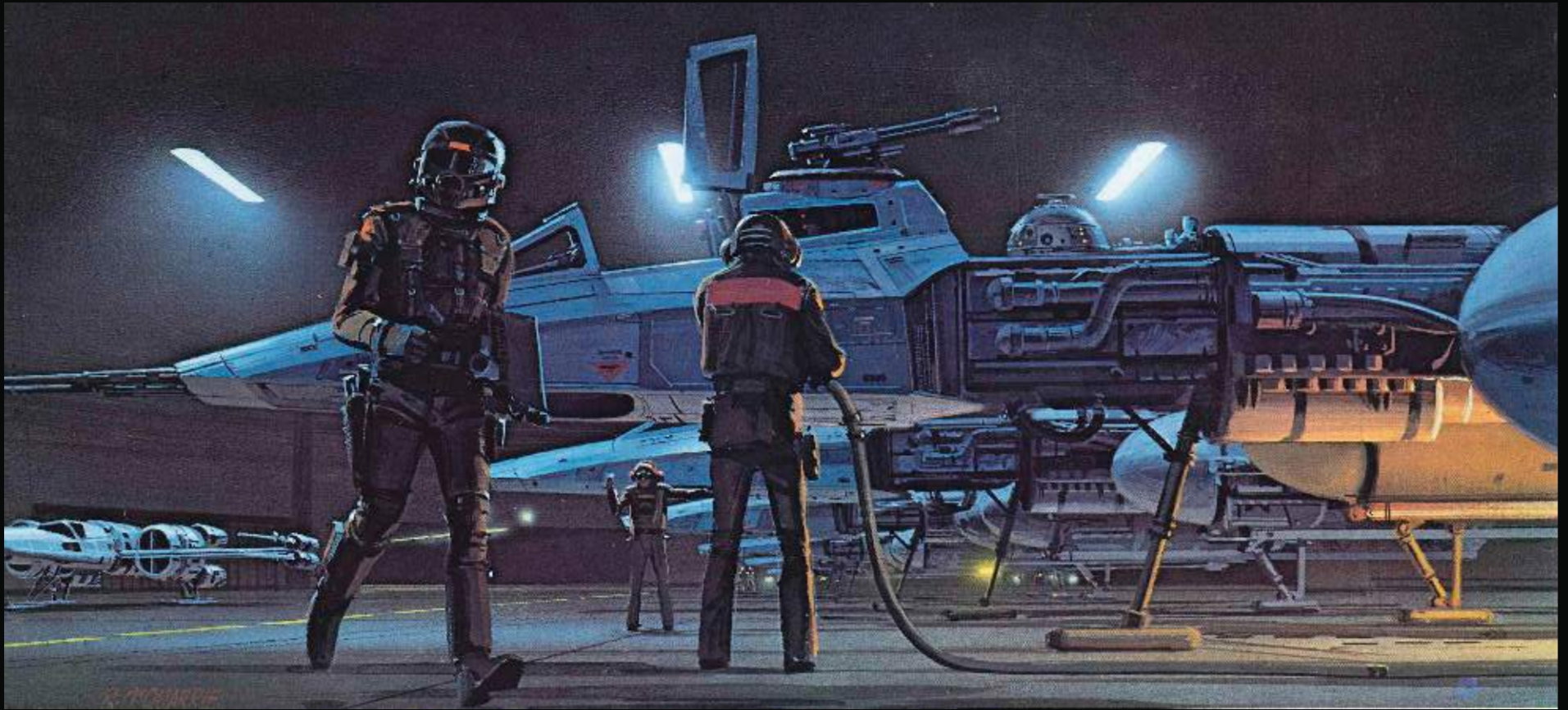

Ralph McQuarrie © & ™ Lucasfilm Ltd.

ABOUT THE Y-WING STARFIGHTER™

Glistening with stardust and laden with heavy proton bomb payloads, the Y-wing was a robust fighter-bomber originally designed for use in the Clone Wars. This long-range bomber was eventually superseded by capital ships in the Imperial Starfleet however; so surplus ships were sold, reclaimed, or stolen for use in the Rebellion. Nicknamed “wishbone” by the rebels who used this spacecraft, due to its shape, the Y-wing became an invaluable resource in the fight against the Galactic Empire.

The Y-wing’s design was well-shielded and included aesthetically pleasing fuselage plating when first introduced during the Clone Wars, but the superficial hull plating required continued maintenance, and had to be removed each time work was needed on the interior of the ship. Thus, when the Y-wing was enlisted

into service for the Rebel Alliance, many maintenance crews left off the plating entirely, leaving the main hull exposed. This change lightened the weight of the spaceframe and also served to cool the engines faster, which boosted the performance of the Y-wing.

With a powerful ordnance and reliable hyperdrive, the Y-wing was used in numerous conflicts. The sturdy hull and defensive shields allowed the ship to survive flak hits during bombing runs, but due to its speed, the Y-wing was vulnerable in dog fights with the much faster TIE fighters. As a testament to the Y-wing’s utility, the rebel group on Yavin 4 stocked its Gold Squadron entirely with powerful Y-wings.

FACTS/SPECIFICATIONS

BTL Y-wing Facts

Manufacturer.....Koensayr Manufacturing
Model.....BTL Y-Wing Starfighter
Affiliation.....Rebel Alliance

Technical Specifications - BTL Y-wing

Length.....16.24 meters
Height.....2.44 meters
Maximum atmospheric speed.....1,000 km/h
Hyperdrive rating.....Class 1.0
Armament.....Taim & Bak IX4 laser cannons (2)
SW-5 ion cannons (2)
ordnance launcher
Engine unit.....Turbo-modified R200 starboard ion engine
Crew.....1 pilot
Astromech droid

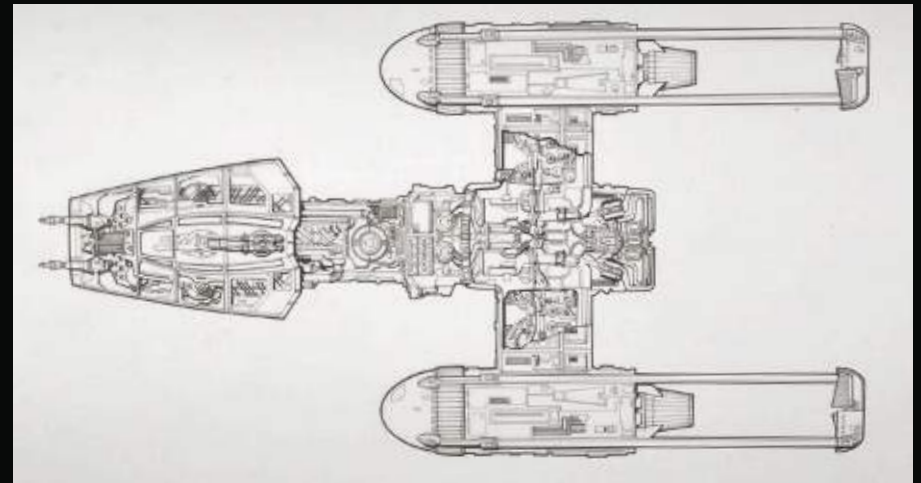
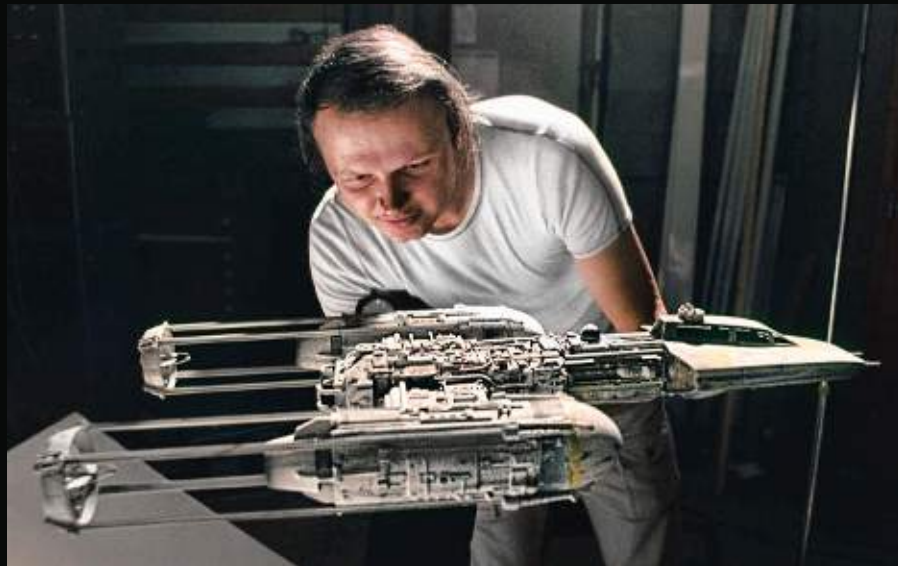
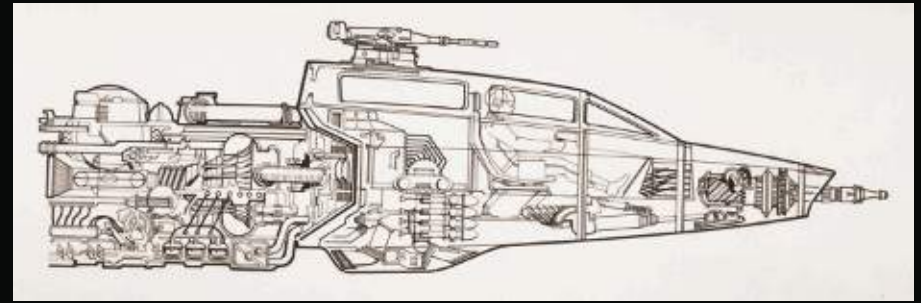

MEET THE MODEL DESIGNER

Jordan David Scott

Q: There are many unique and storied vehicles in the *Star Wars* universe. What is the process behind choosing the next amazing LEGO® *Star Wars* vehicle the team will create?

A: Deciding the next model is a long process with many factors in play! First, we look at our fans' feedback and requests for new potential models. We also look at earlier versions of a potential new model; how long ago was it launched and how can we improve it in a new version? Finally, if there is a new *Star Wars* movie out, or other relevant content, this can also influence our choice for a new model.

Q: There are several different versions of the Y-wing; the BTL-S3 two-man strike fighter, the BTL-A4 with a front-facing ion cannon, the "Longprobe" model and of course, the very first version, the BTL-B. How did you decide which Y-wing version would be built in LEGO brick form?

A: We wanted to make the most iconic depiction of the Y-wing from the *Star Wars* universe. The BTL-A4 Y-Wing Starfighter appears in *Star Wars* Episode IV: *A New Hope* in the trench run scene. It is one of the most iconic *Star Wars* scenes, so we had to go with this version.

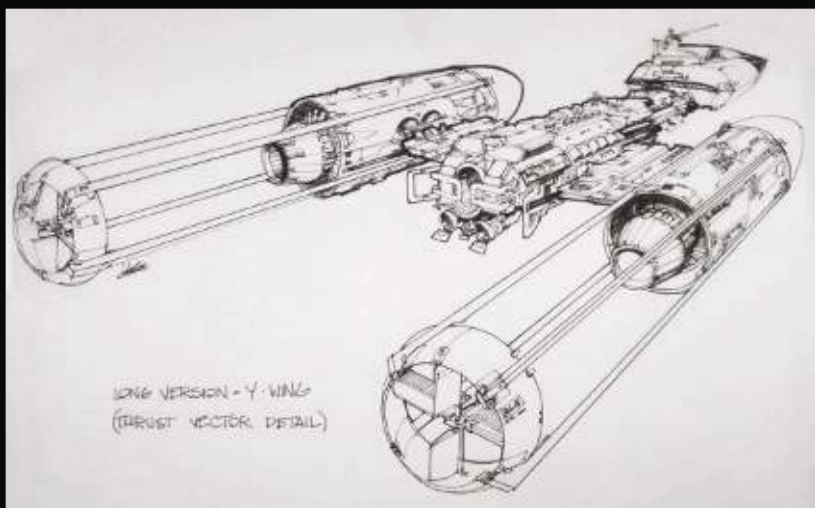

© & ™ Lucasfilm Ltd.



Jordan David Scott

Q: The Y-wing was known for having removable hull plating that was often left off. What techniques did you use to ensure the model would be robust enough with so much fuselage exposed?

A: When I started to build the Y-wing, I knew that the engines on the sides were going to be my biggest problem. They are very long and very thin. This also affected the balance point and made locking these engines quite tricky. I tried a few different designs, but in the end it turned out that a simple Technic frame and some very stable cross axles were all I needed to make it strong and easy to build. This allowed me to hide the entire construction in the amazing details of the Y-wing's exposed fuselage.

Q: What sets the Y-wing apart from other LEGO *Star Wars* sets?

A: I think this is one of the few UCS *Star Wars* sets that has so much greebling, literally every part of the model is packed with intricate small details and builds.

Q: Was any part of the Y-wing particularly challenging to recreate with LEGO® bricks? How did you solve the problem?

A: Most definitely. The engines on the sides as I mentioned were very tricky to make stable, but the most challenging part was that they are cylinders. The previous version of the UCS Y-wing was more square in its construction, so I wanted to try and improve this, but it led to a lot of building challenges. The support pylons that run all the way down the engines are built on 4 sides, which is easy to build. However, the challenge was then attaching the whole engine to the chassis of the model. My connection points were on the same angle as the support pylons, which isn't accurate. I had to use some very weird builds with turntables to get this 45-degree angle connection point. After that, I still had to build in the details and make it look round. It was a big challenge but I am glad it paid off in the end, and I think it looks pretty accurate... I hope fans do, too.

Q: How accurate is the LEGO Y-wing, compared to the real in-universe vehicle?

A: In my eyes, it's pretty accurate. I had a lot of great reference from Lucasfilm and model kits around the office. However, like the studio-scale models, several were used for filming different scenes, so it was very difficult to pinpoint exactly which Y-wing I was building from. In the end, I would say the LEGO® Y-wing is a combination of a few different models.

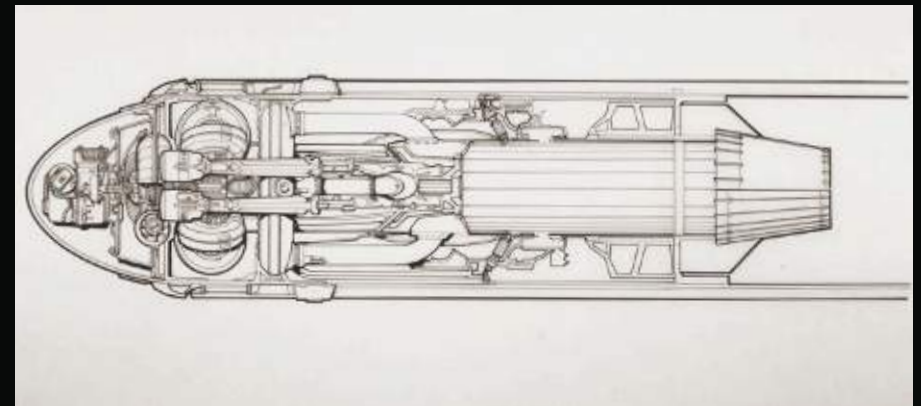
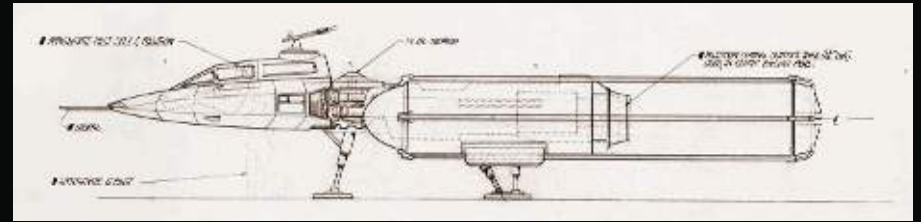

© & ™ Lucasfilm Ltd.

Q: What features of the Y-wing were important for you to include in the final design?

A: When looking at the reference images, I particularly liked the sand blue stripe running down the side of the cockpit. The stripe made for an interesting build but I think it worked out, and a similar technique was used on the smaller retail product from *Rogue One*. Another detail I wanted to keep, like in the UCS Snowspeeder I worked on, was the detailed underside of the model. I feel it is very important to make sure that no matter which part of the model you look at, there are accurate details from the movie.

Q: What goes into the colour selection of the LEGO bricks used to create the model? Do you try to match the colours of the vehicle from the film, or are there other elements taken into consideration?

A: For the exterior of the model, we definitely have to match it as closely as possible. Luckily, the Y-wing is quite muted in colour but with some nice accents. For this, I used lot of grey and dark grey but then added in some splashes of brown and dark red for piping and dark tan for some more rusty, worn details. Inside, the model is quite colourful to make the building experience easier. I am from Scotland so I always try to hide a blue and white brick in the build somewhere. The cockpit is all white, so that wasn't too difficult!

MEET THE GRAPHIC DESIGNER

Madison O'Neil

Q: How do you begin the graphic design process for a new set and new minifigures?

A: When the graphic design process begins, we usually have a solid idea of which characters we want to include. From that point, I move to reference-gathering and graphic design exploration. Exploration usually involves creating several different versions of the same design, playing with the colour choices and sizes of elements. I will occasionally sketch by hand, but most of the time I start directly in Adobe Illustrator. We then have several rounds of discussions and reviews within the *Star Wars* graphic design team to make refinements, and of course Lucasfilm approval is the final step where revisions may be required.

Q: What challenges do you face when creating designs that need to be recognisable and sufficiently detailed, but also small enough to fit on a minifigure?

A: The greatest challenge comes from *Star Wars* characters that are overloaded on detail. A standard minifigure is tiny, and very differently proportioned from an actual human. Fitting in all the important details can sometimes feel like a jigsaw puzzle. But, part of the LEGO® DNA is simplification. We determine the most important details to prioritise in our characters, perhaps eliminating small things that add little value to a design at this scale.



Madison O'Neil



© & ™ Lucasfilm Ltd.

Q: Are there any memorable details from the movie versions of the minifigures that were important for you to incorporate in the final design?

A: Most important in this set was of course the helmet of Gold Leader, a.k.a. Jon "Dutch" Vander. The olive green colour and the symbols on its sides make it quite unique.

Q: What do you find enjoyable about the minifigure design process?

A: I have the good fortune of being both a huge *Star Wars* fan and a huge LEGO fan, so being able to translate characters from one beloved universe to another is a truly special experience for me. If I had to pick a favorite part of the process, it would have to be the full completion of a design, which to me is when I receive the printed elements for the first time and can hold the character in my hands.

Q: What do you use as reference material for designing the minifigure decos? Film stills? Licensed art?

A: This can depend largely on which film the character is from. If the film hasn't been released yet, we will receive concept art and turn-around images of the character to work from. If the character is from the original trilogy or prequels, I prefer to go back and collect stills directly from the films. I feel that this provides the best representation of how the audience will have experienced a given character, and also provides a good excuse for me to watch *Star Wars* at work! For Gold Leader, I collected images from *A New Hope* and even referenced his brief cameo appearance in *Rogue One*.

Q: Characters from the *Star Wars* universe are very detailed. How do you pick and choose which details to bring to life, and which are ultimately not as important in the final design?

A: I think it comes down to scale and impact. We have many design requirements when it comes to ensuring quality graphics, like minimum stroke thicknesses and dot size. Some details on characters are too small to include simply due to our guidelines. Other small details might be weeded out because they are not as impactful... they are not the things a fan will remember about the character. The most interesting and memorable features are always accentuated.

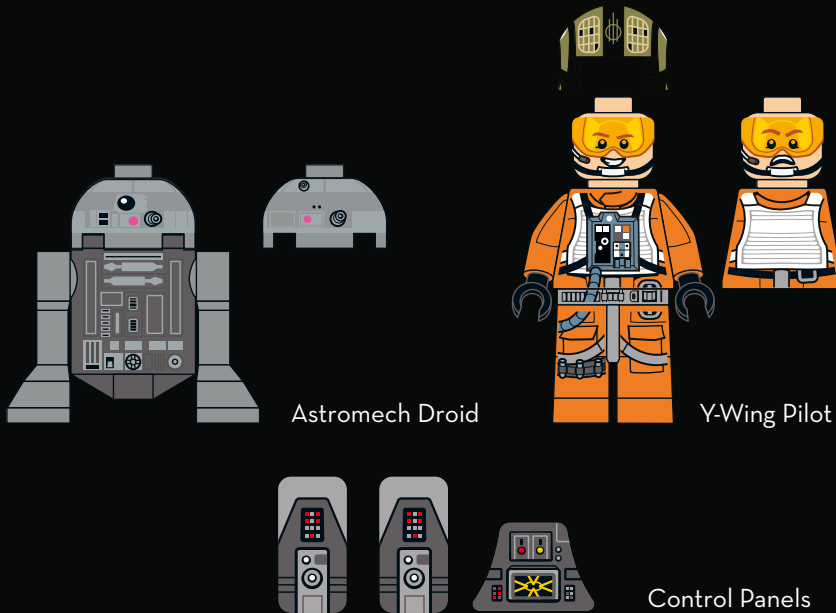

Astromech Droid

Y-Wing Pilot

Control Panels

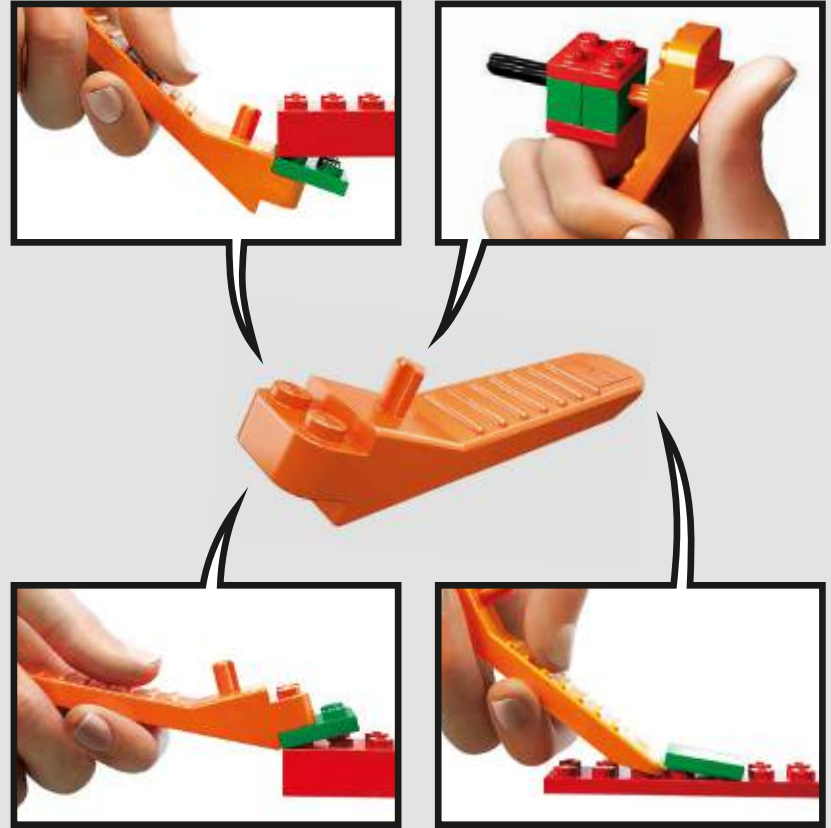

LEGO.com/brickseparator

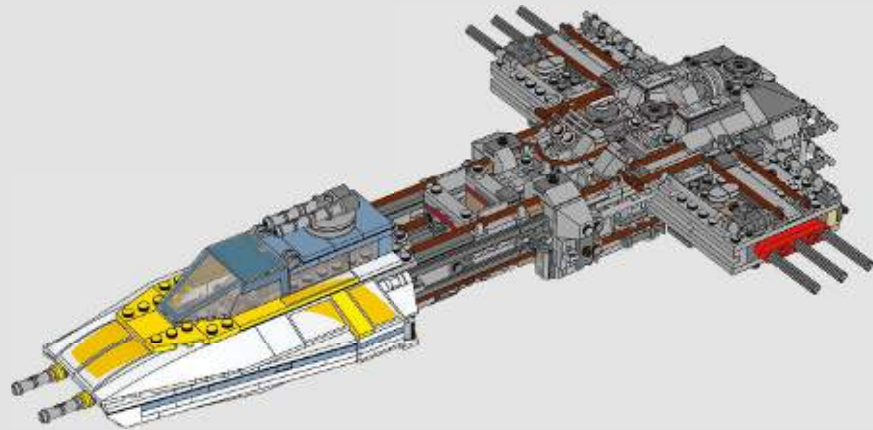
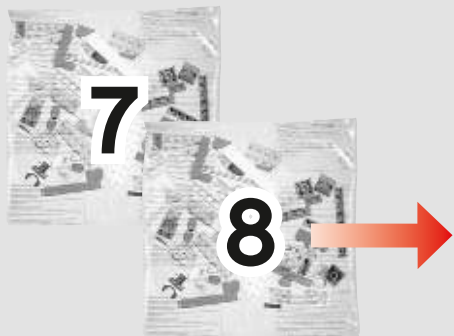
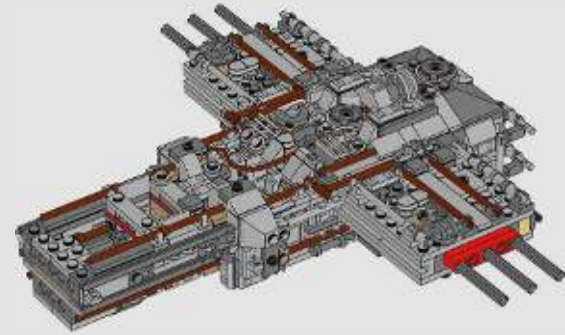
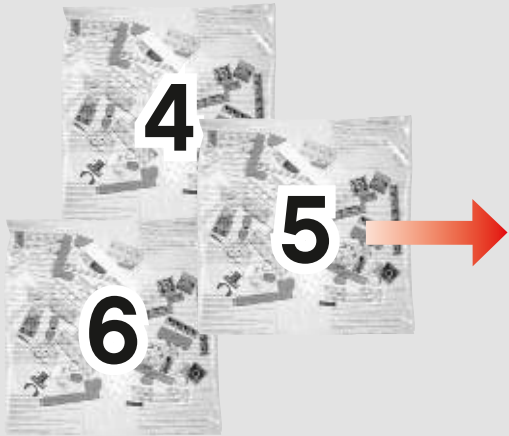
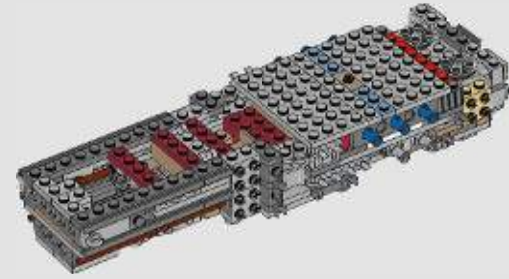
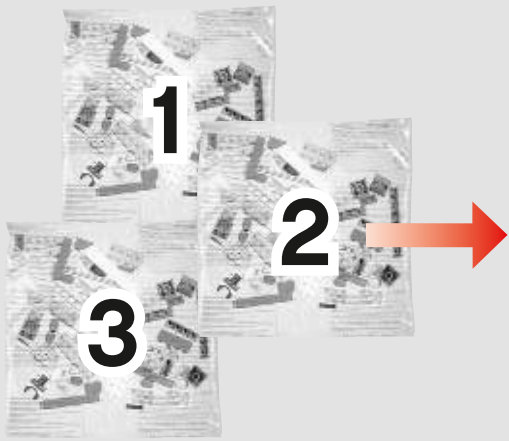

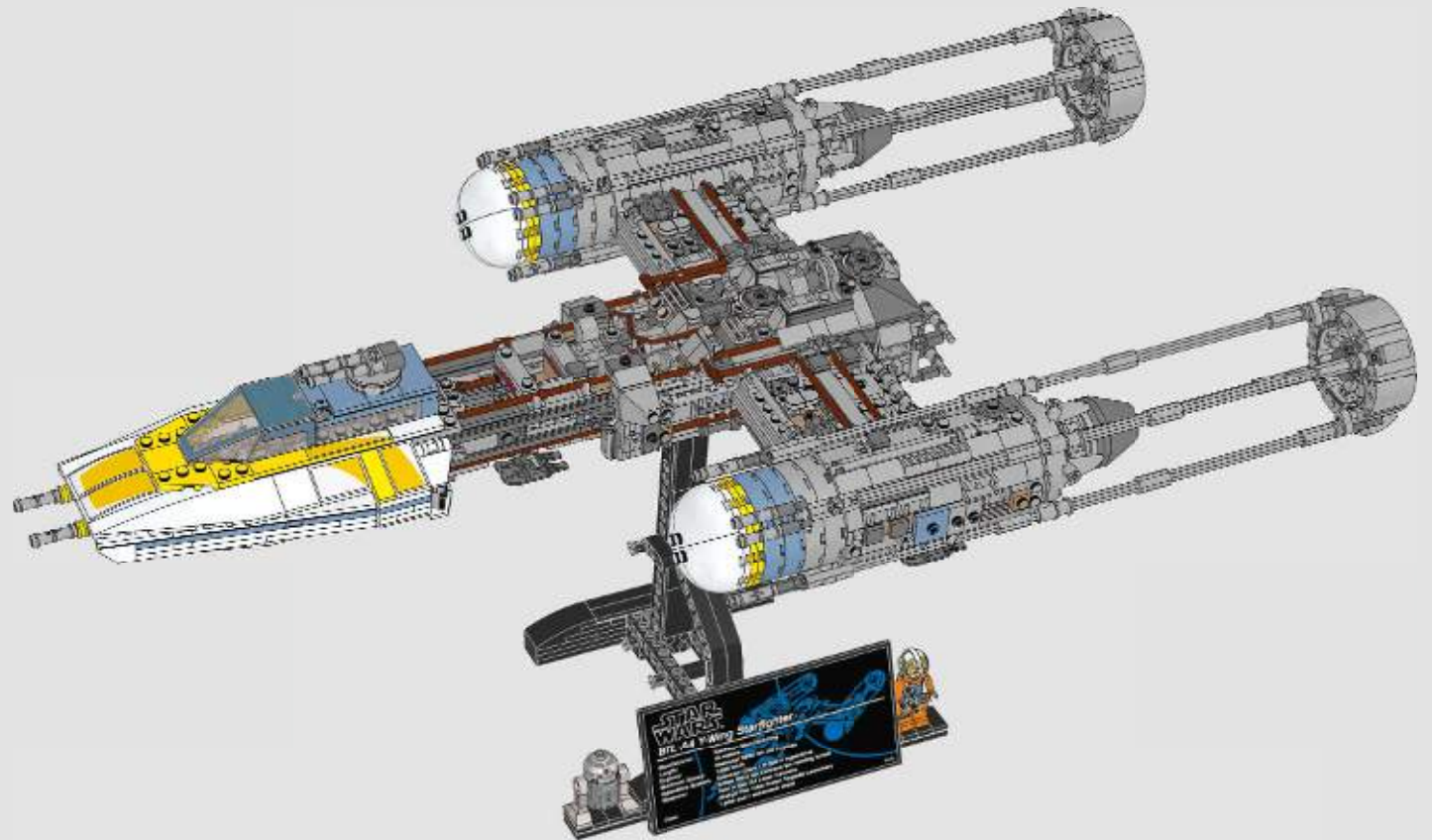
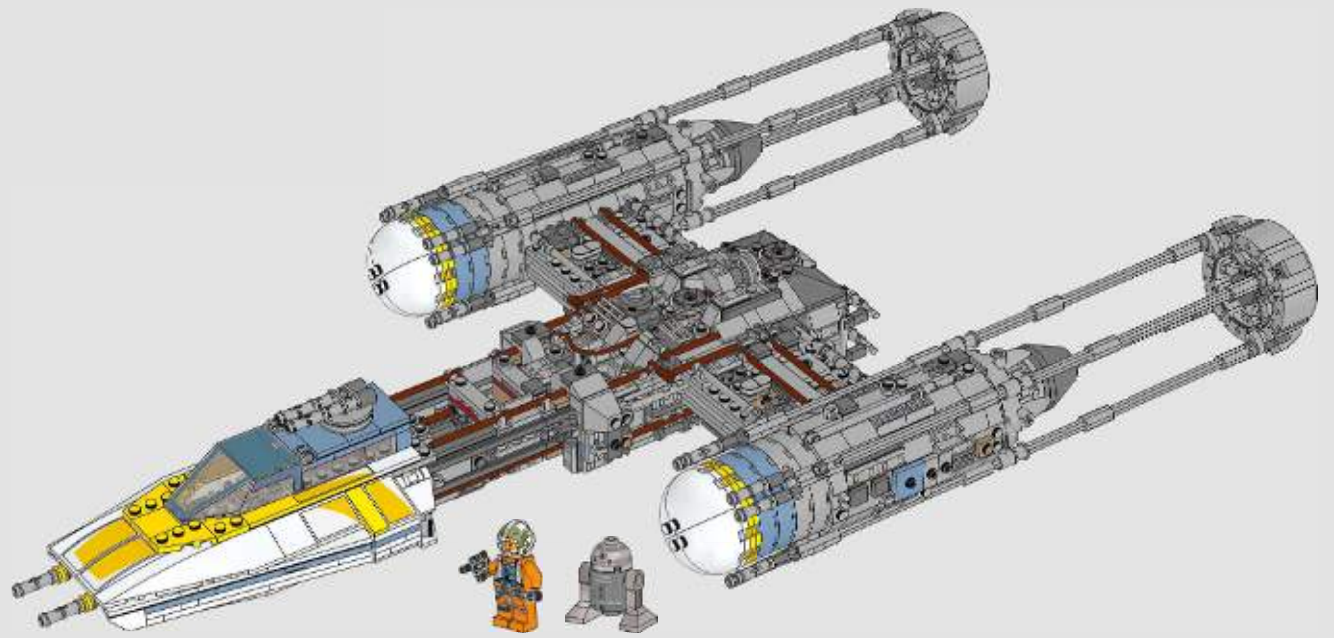
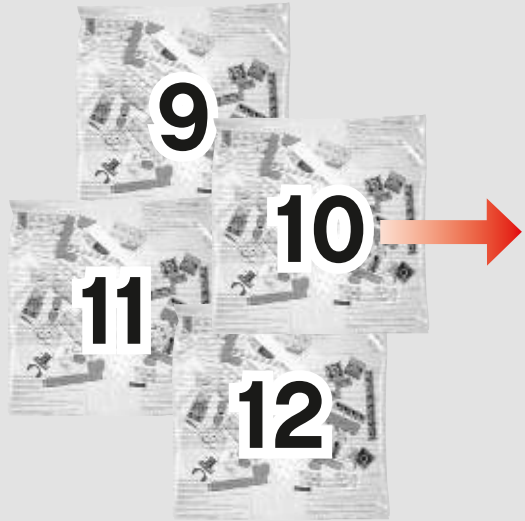

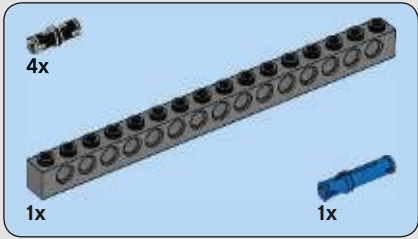
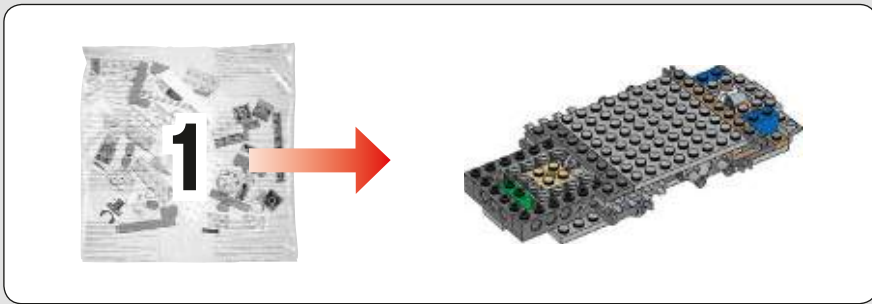

1

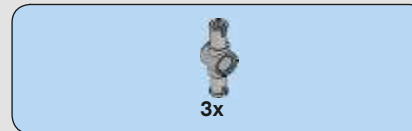
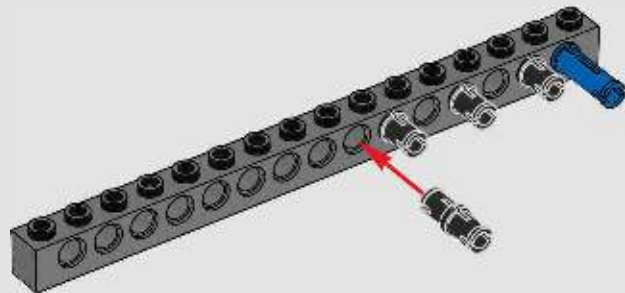

2

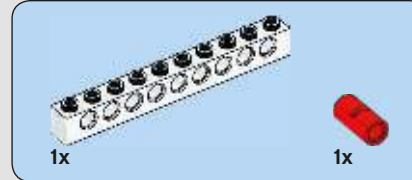
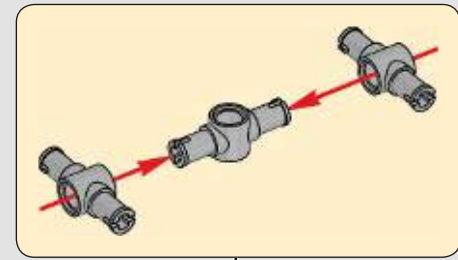

3

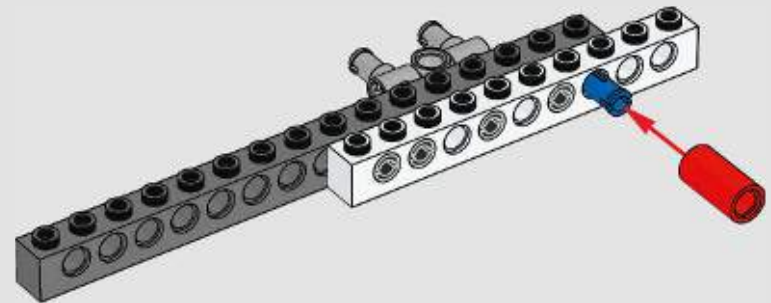

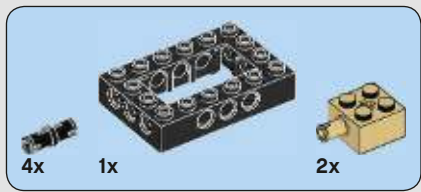

4

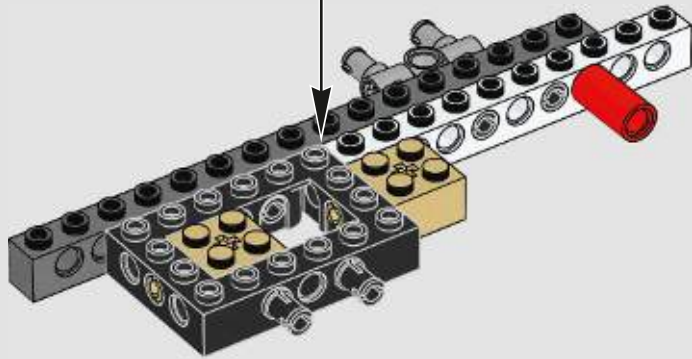
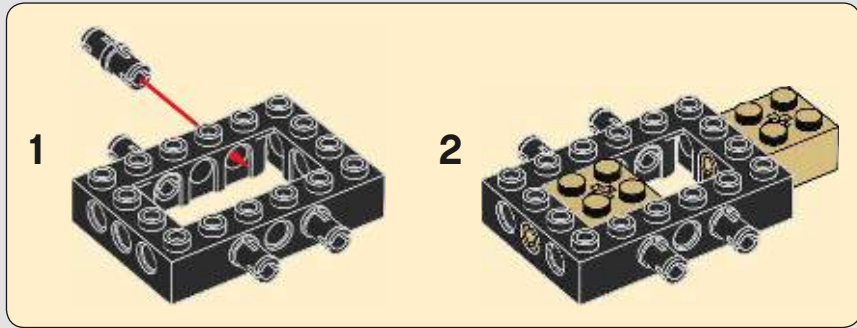

5



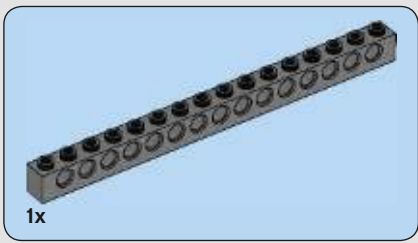

6

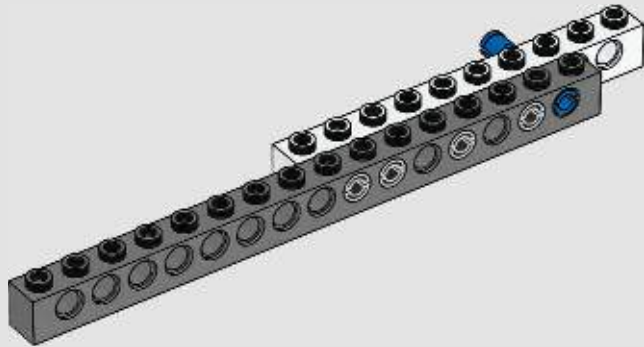

7

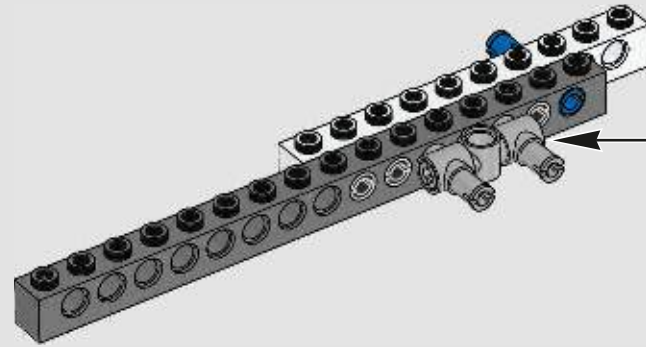
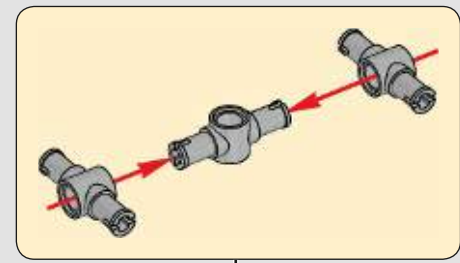

8

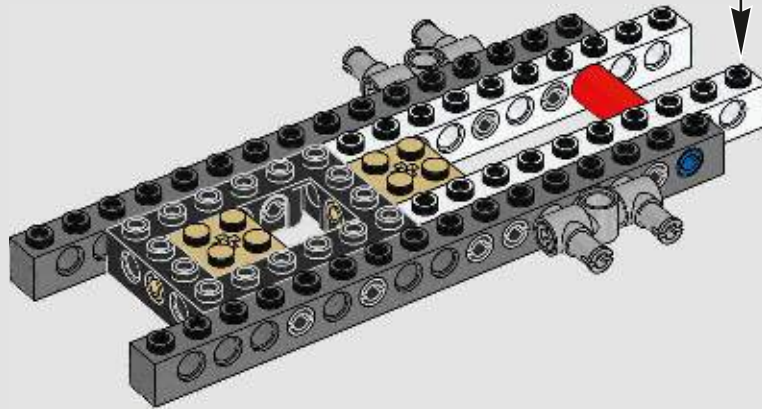

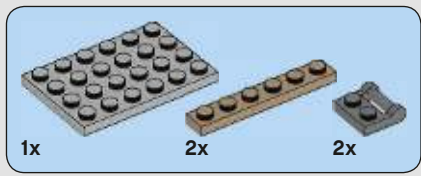

9

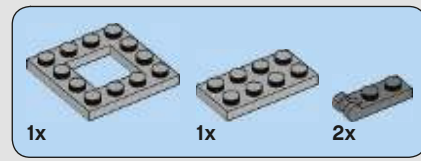
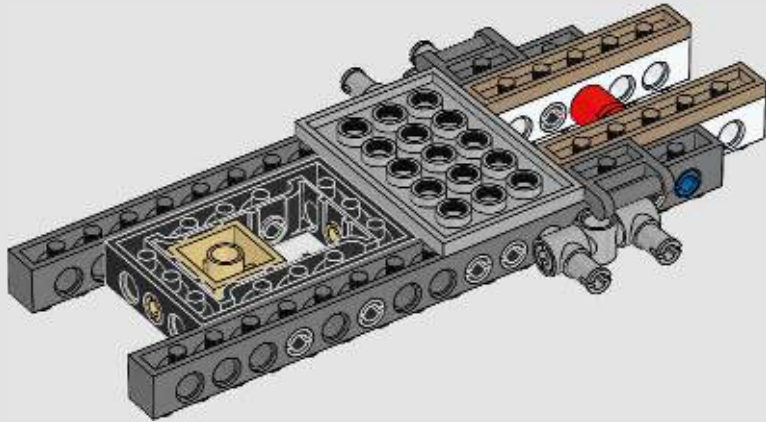

10

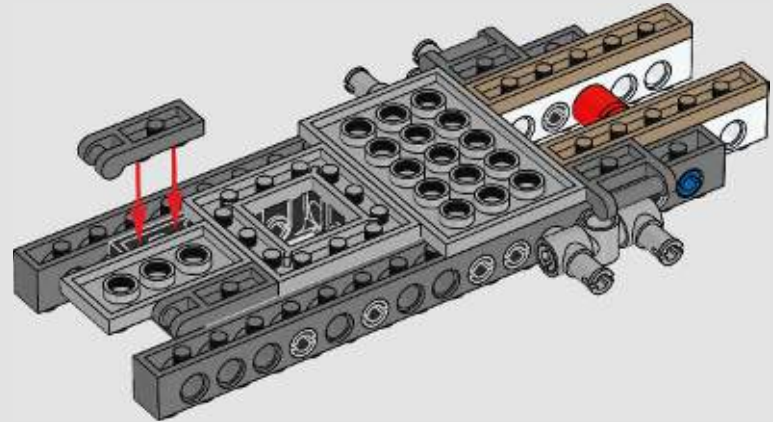

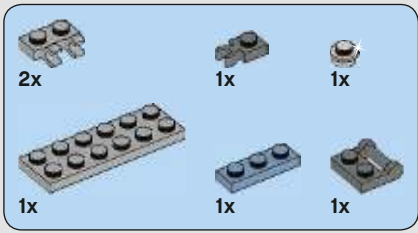

11

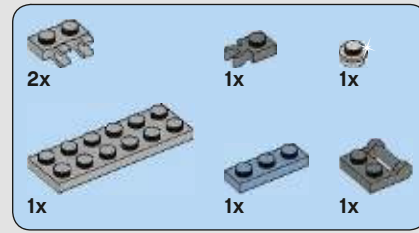
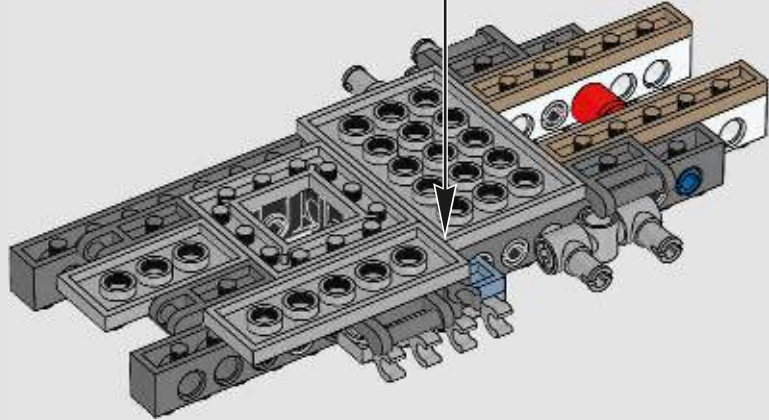
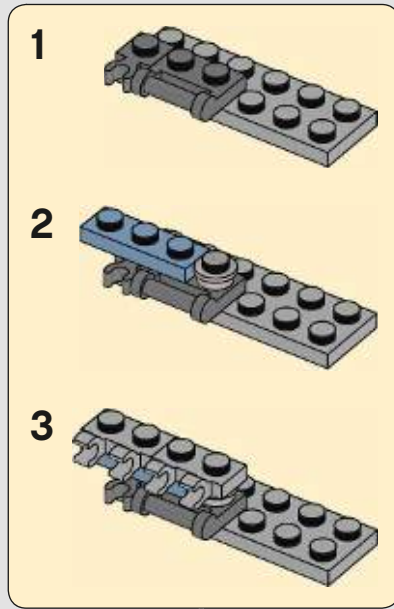

12

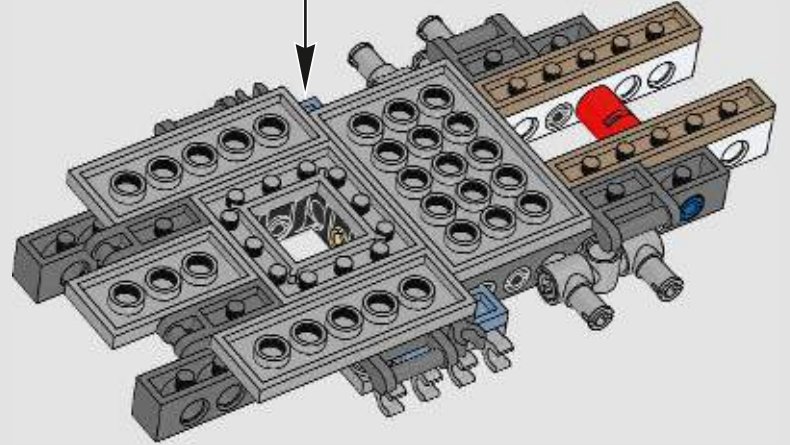
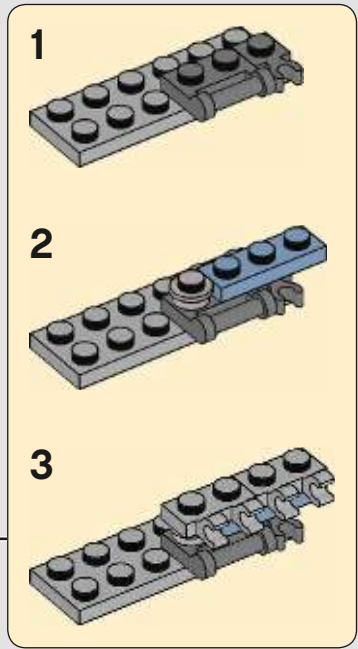



13

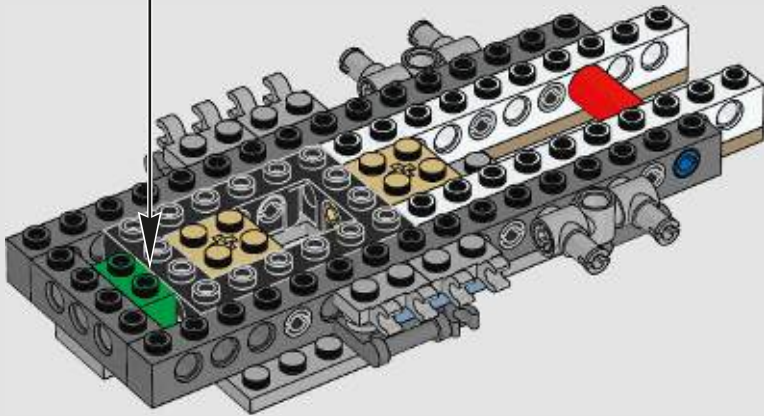

14

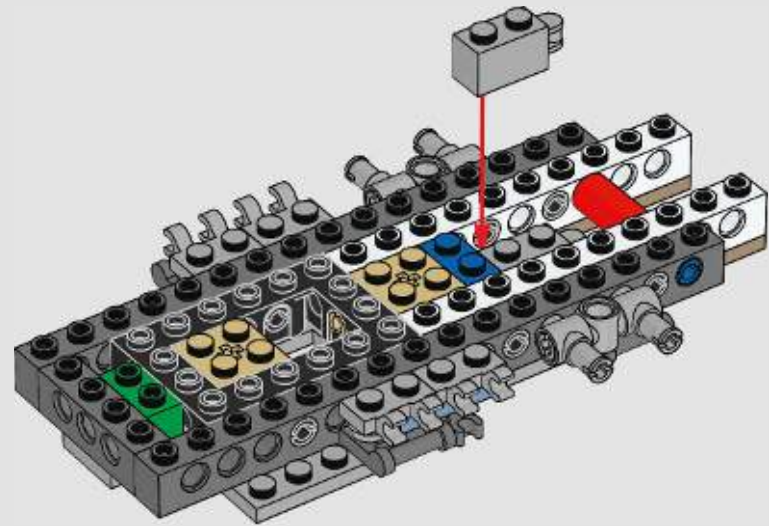

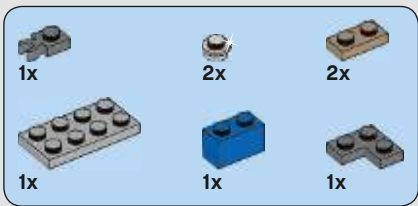

15

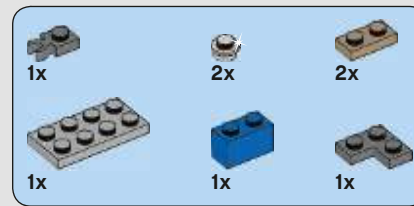
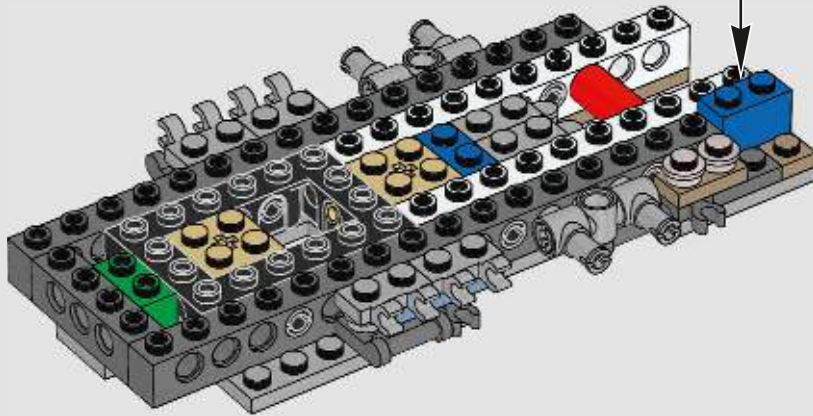
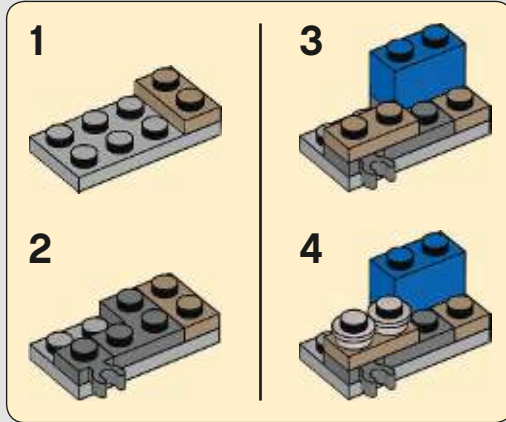

16

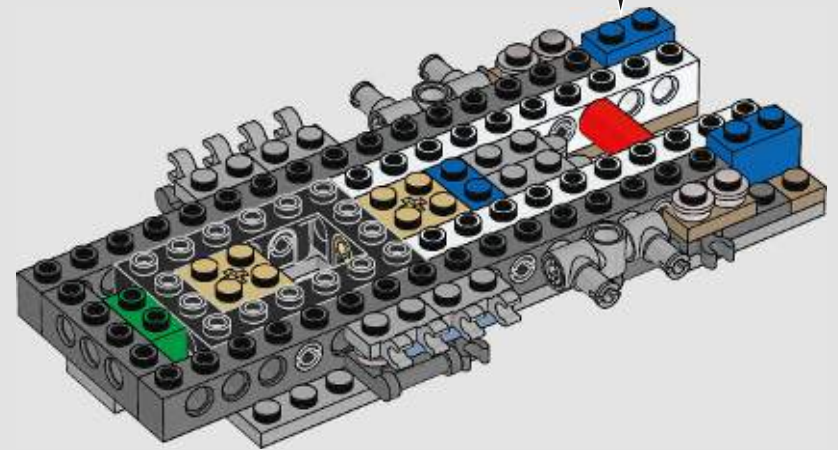
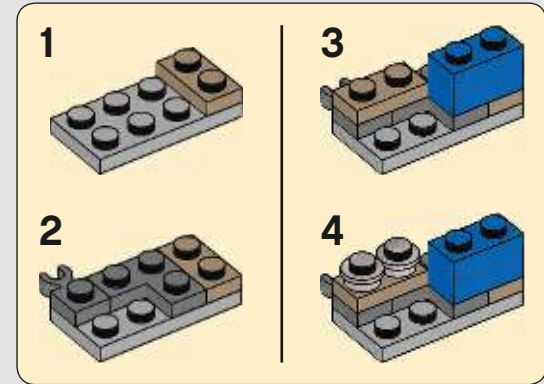

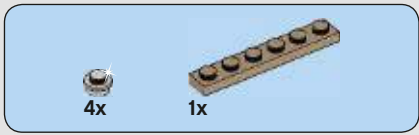

17

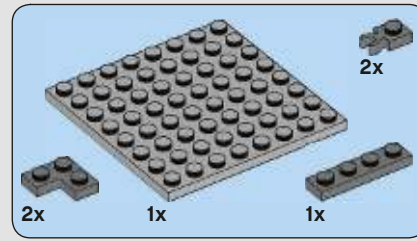
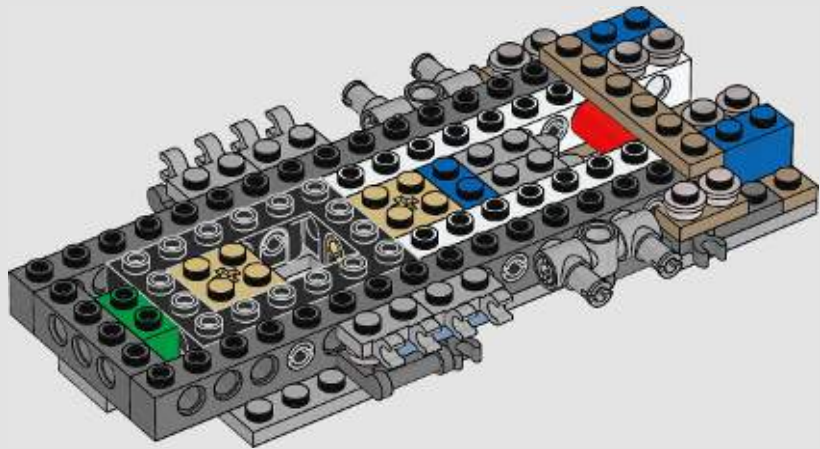

18

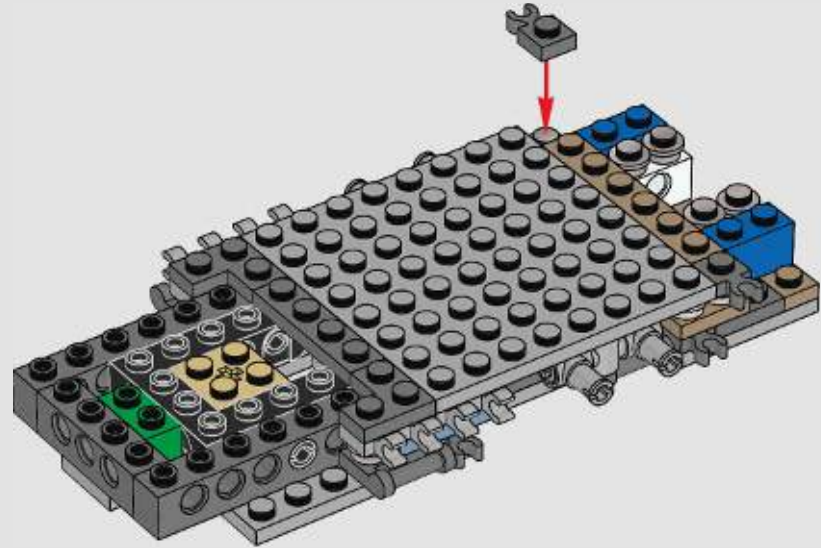

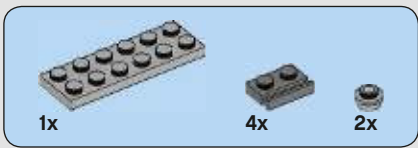

19

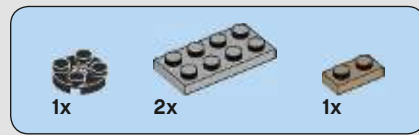
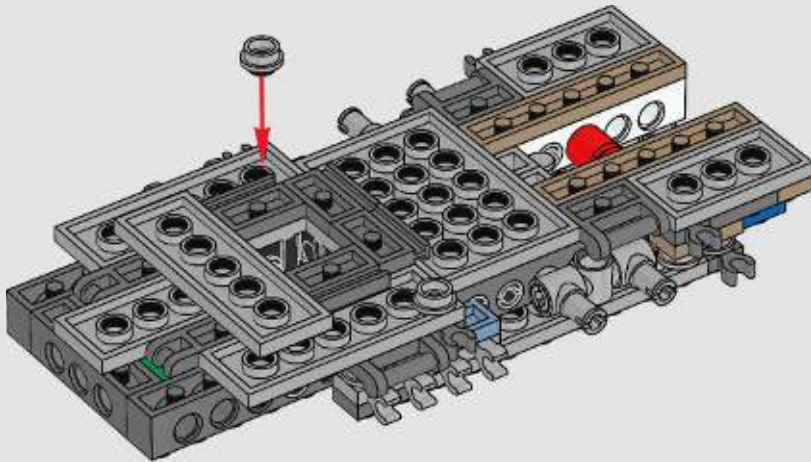

20

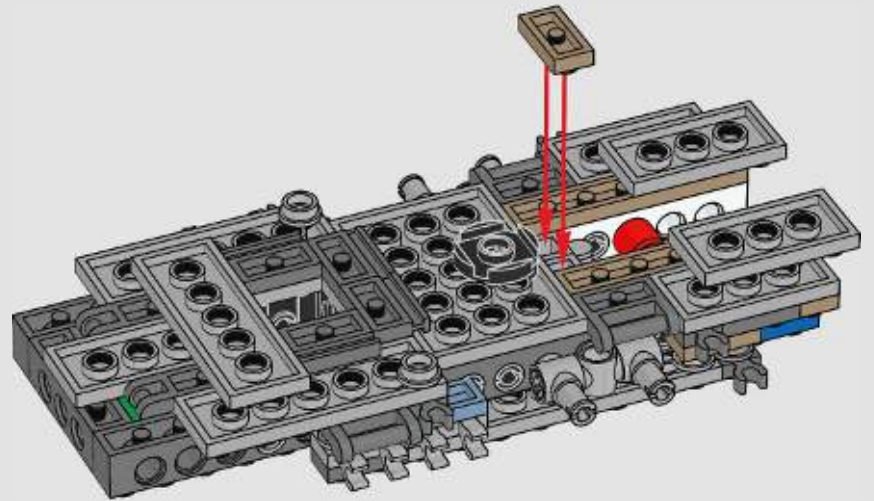

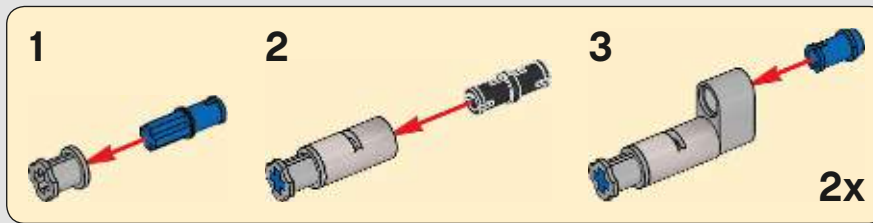
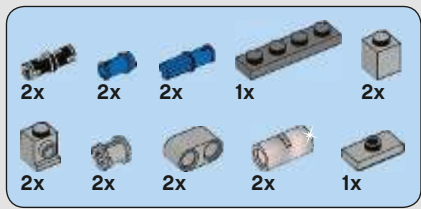

21

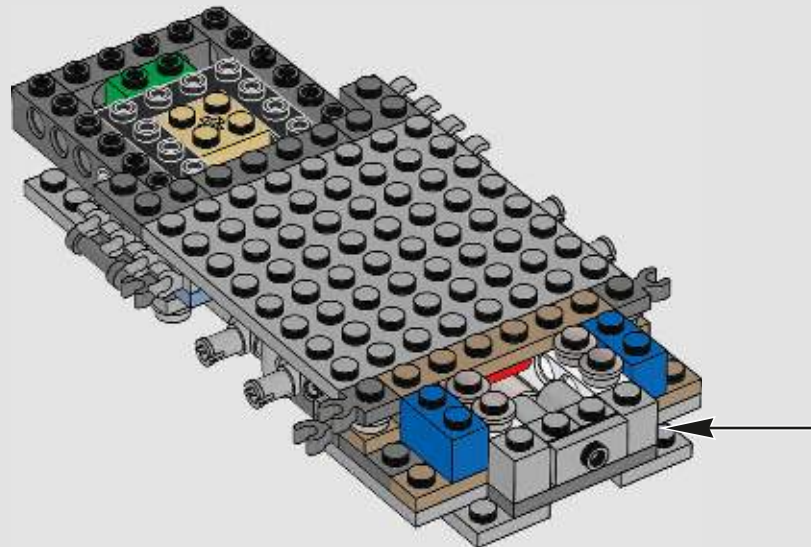
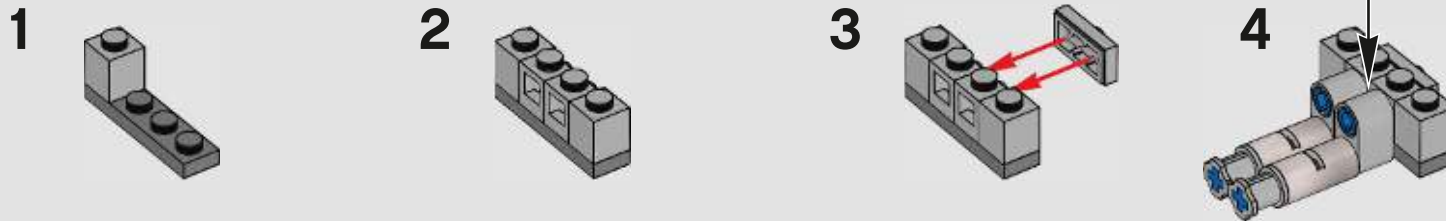



2x

22

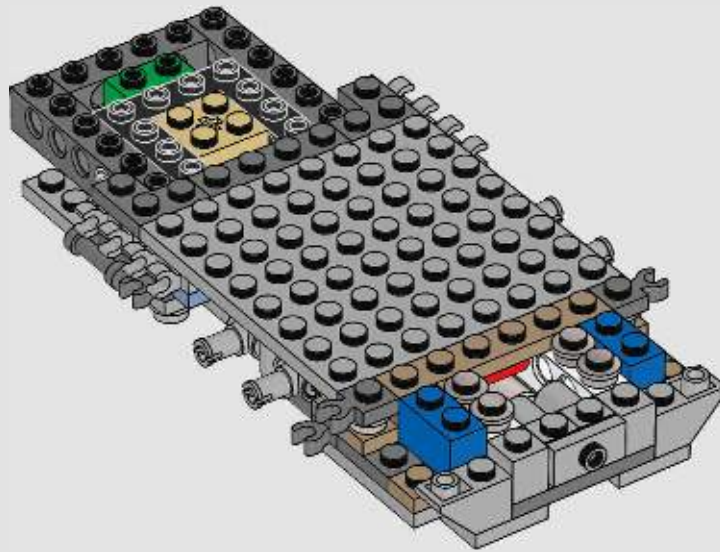



2

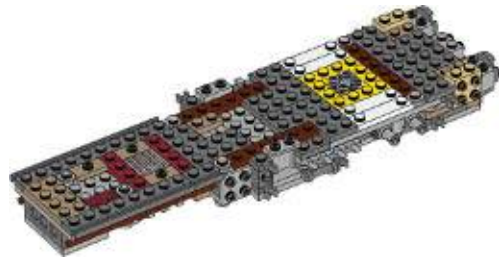

2x



1x

23

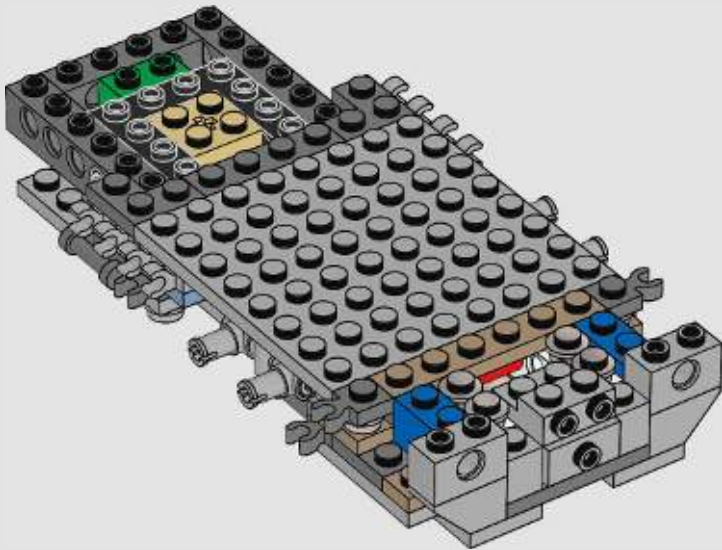

2x



2x

24



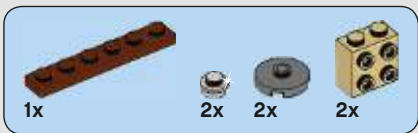

25

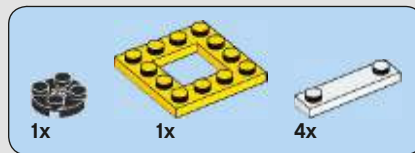
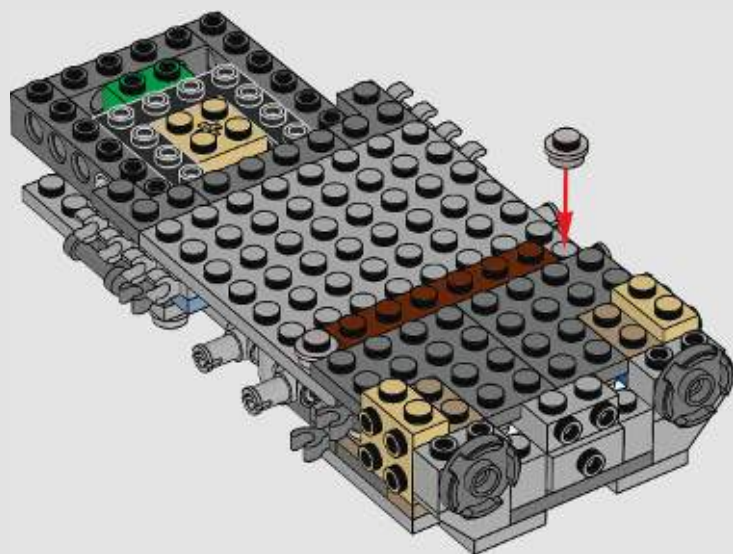

26

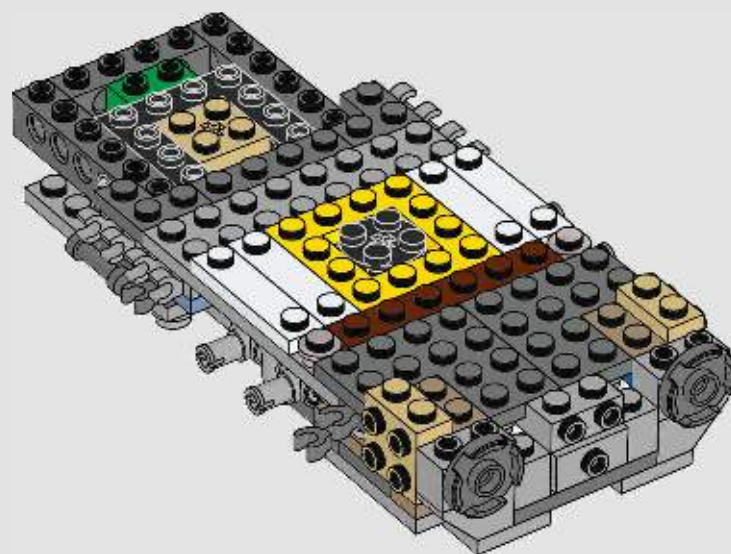

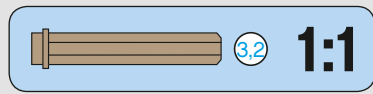
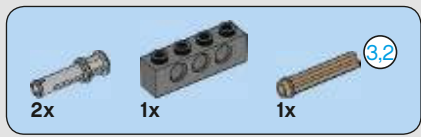

27

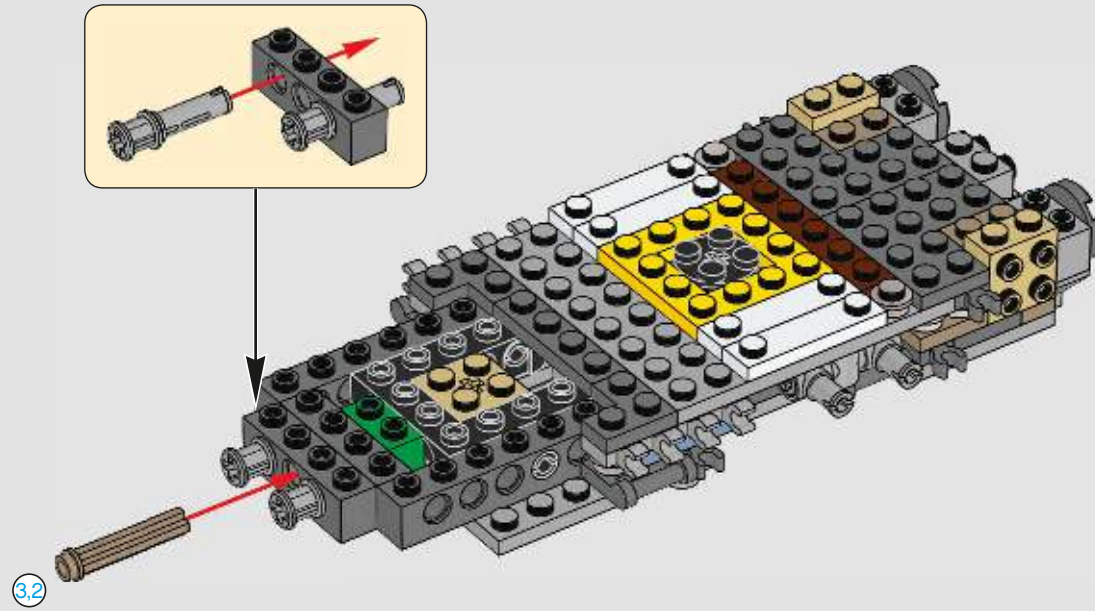

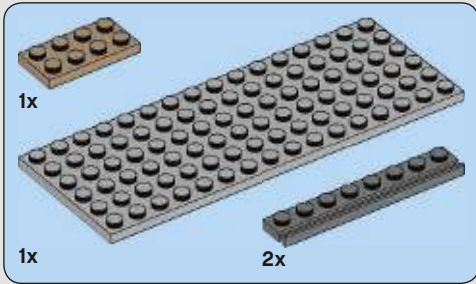

28



29

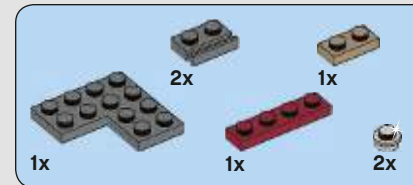
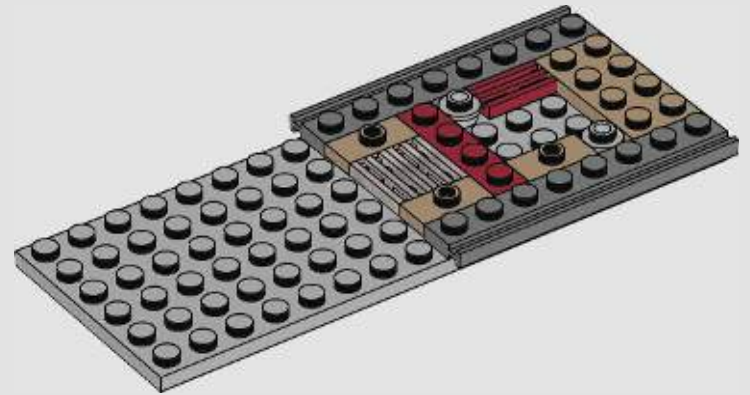

30

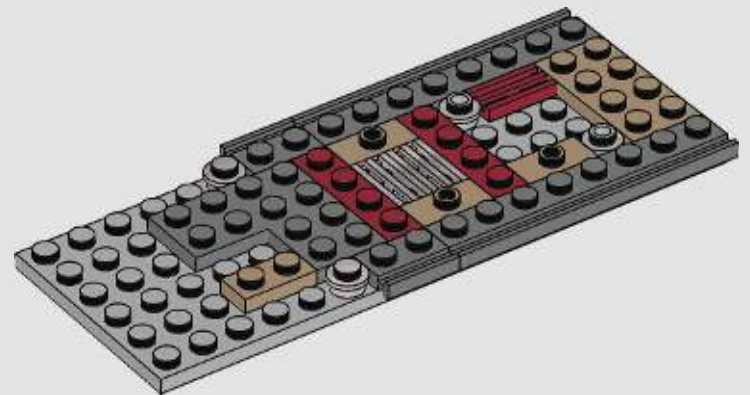



31

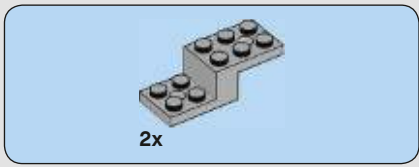
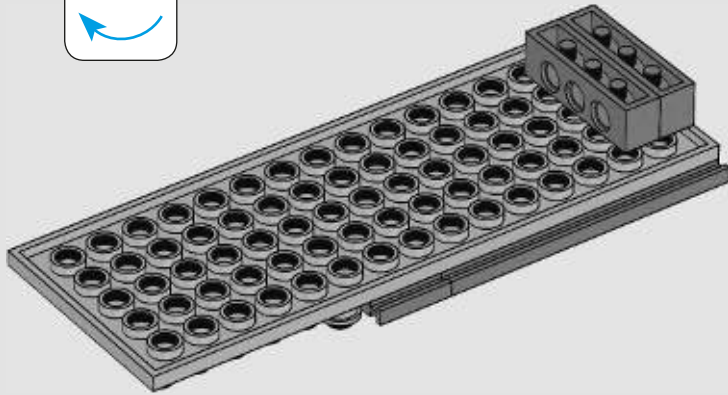

32

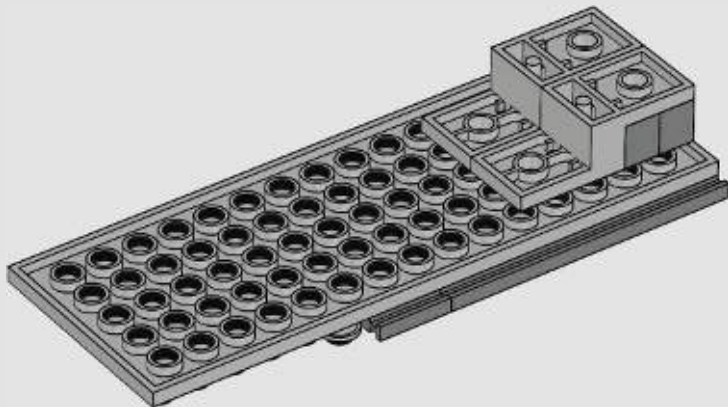

33

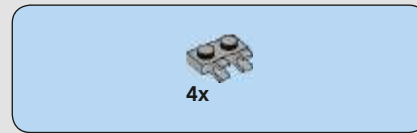
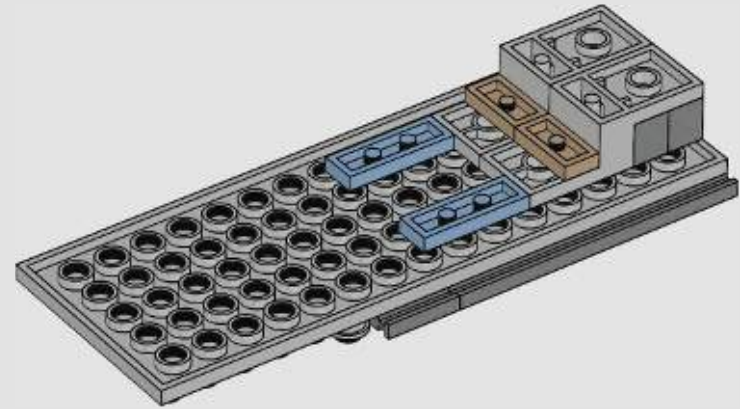

34

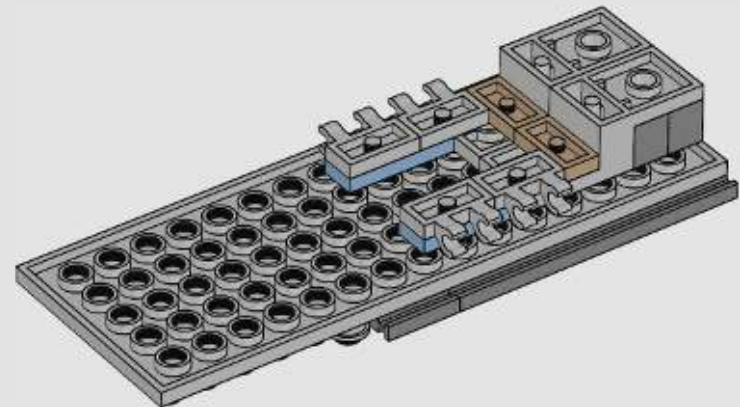

35

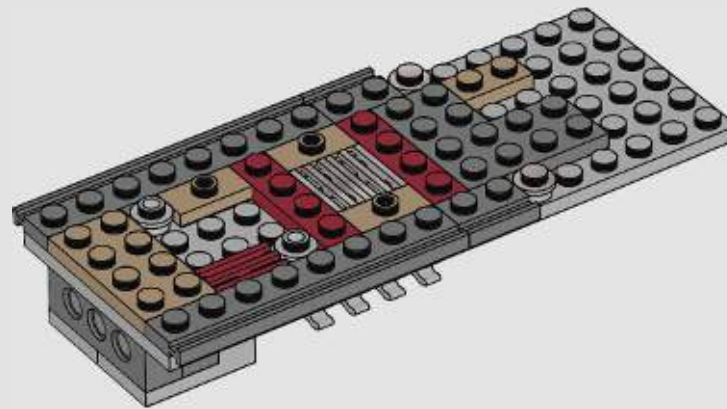
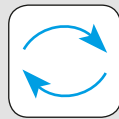

36

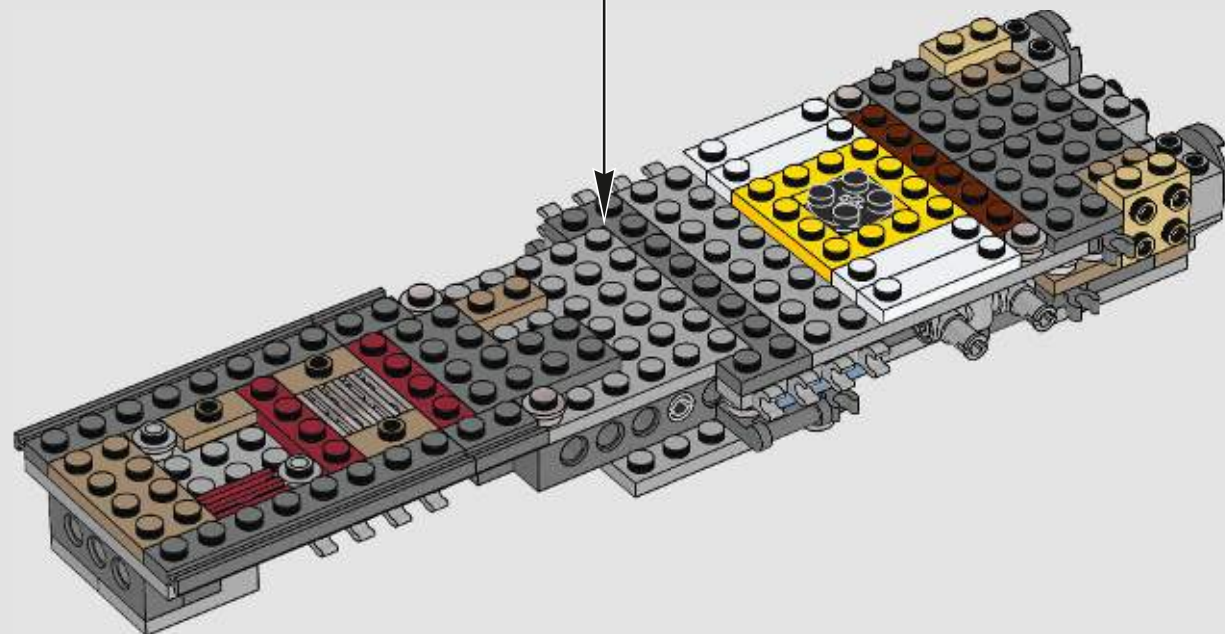

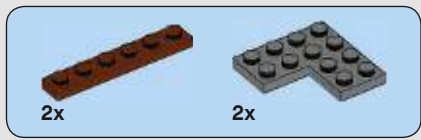

37

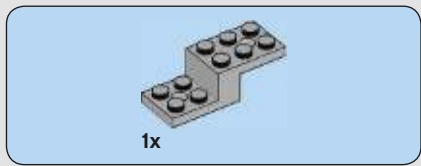

38

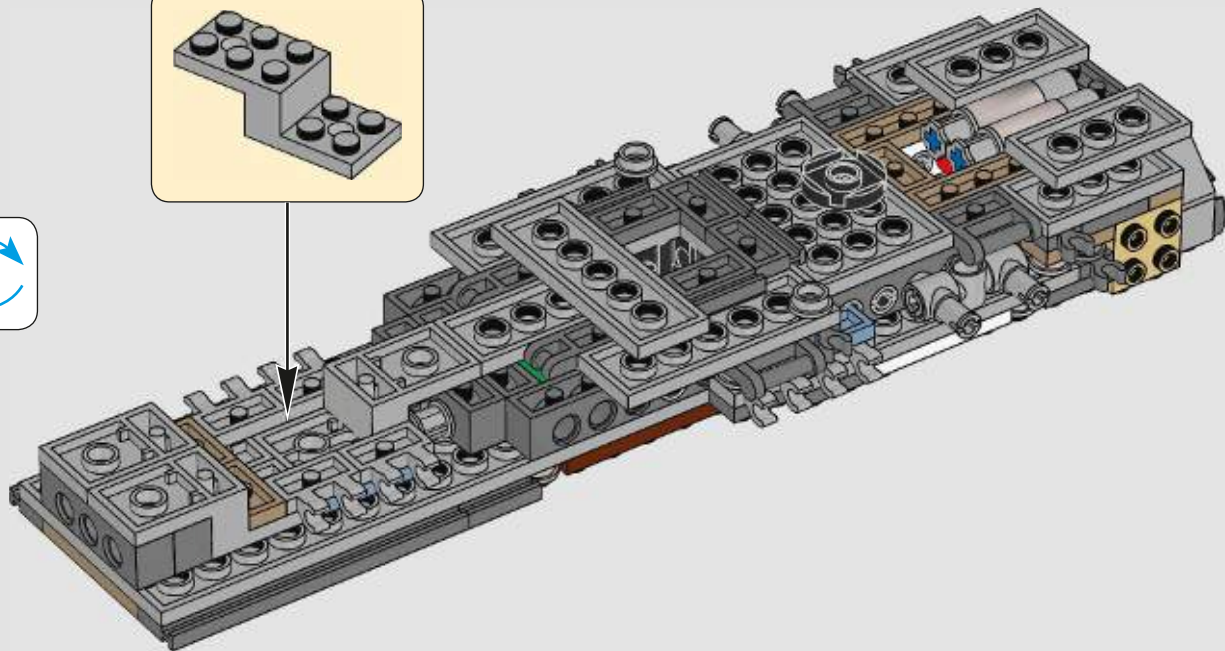
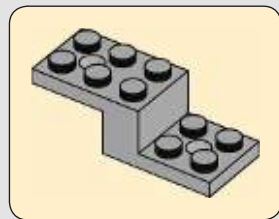



39

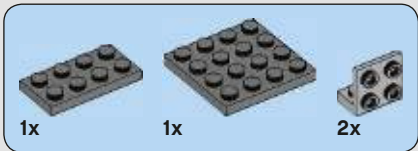
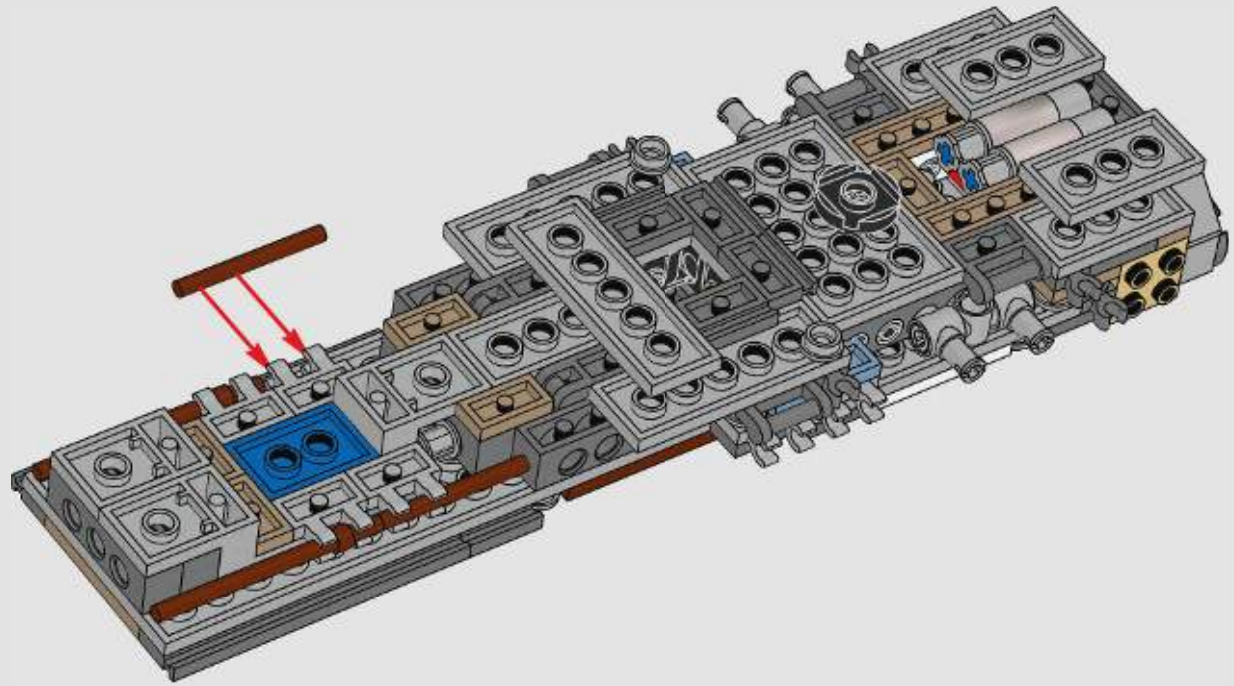

40

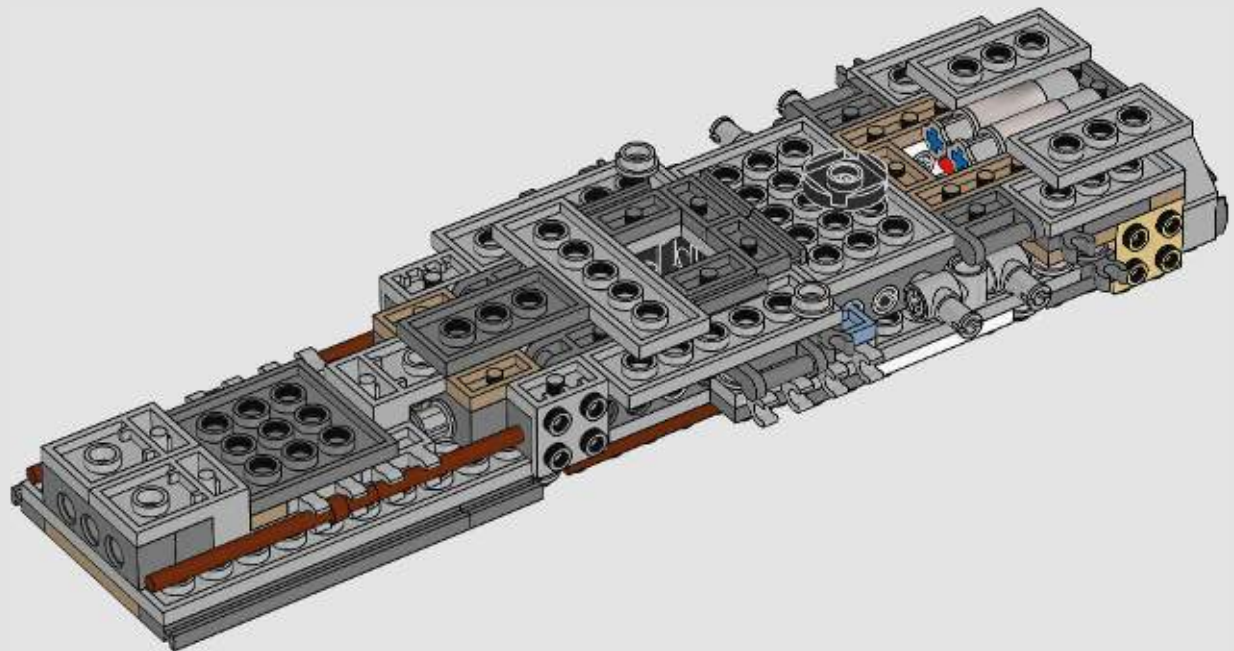



41

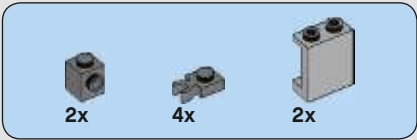
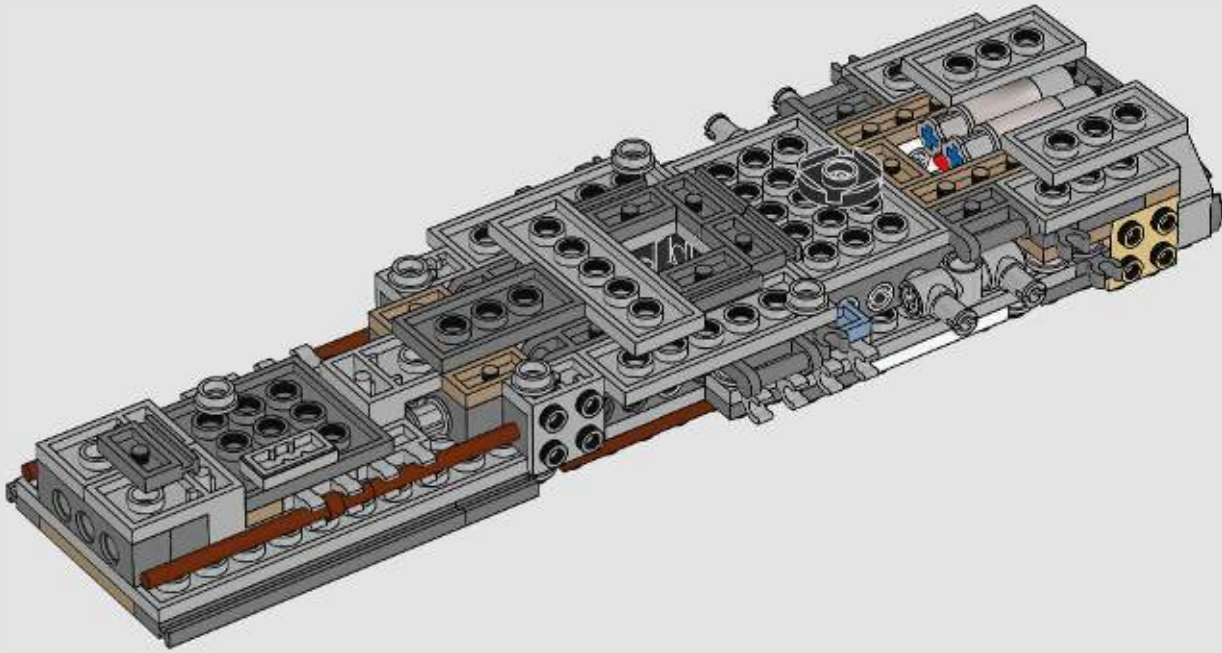

42

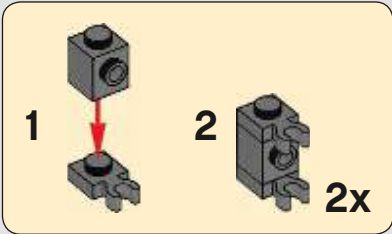
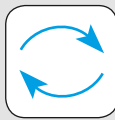

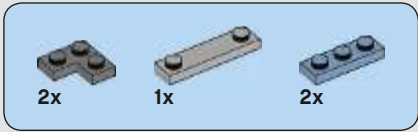
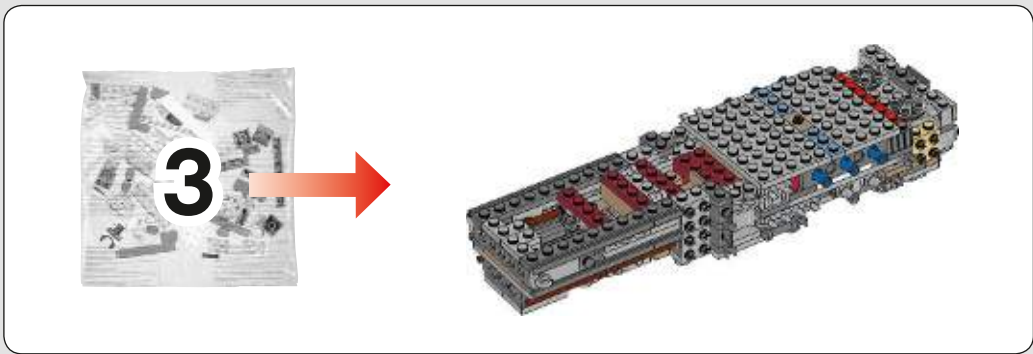

43

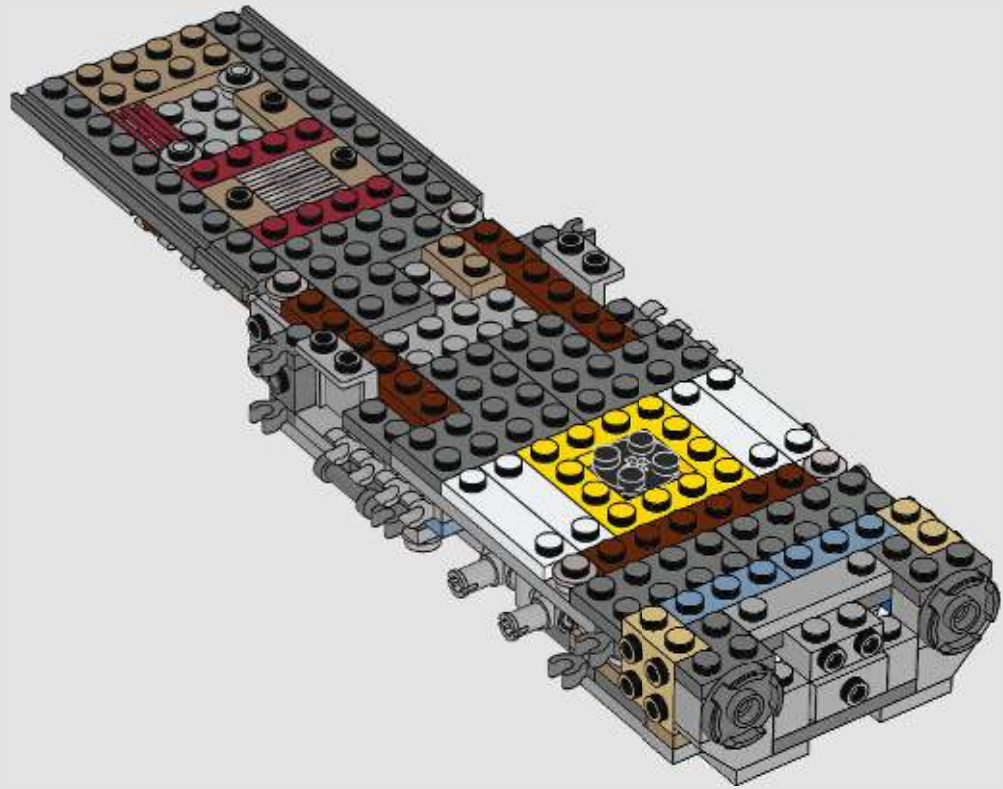

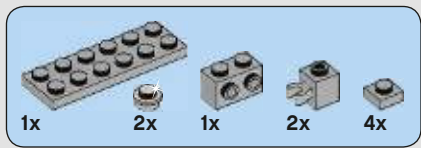

44

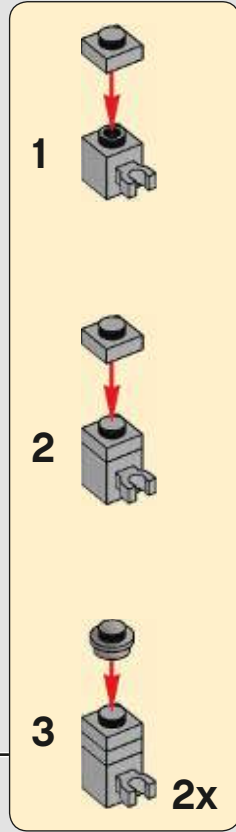
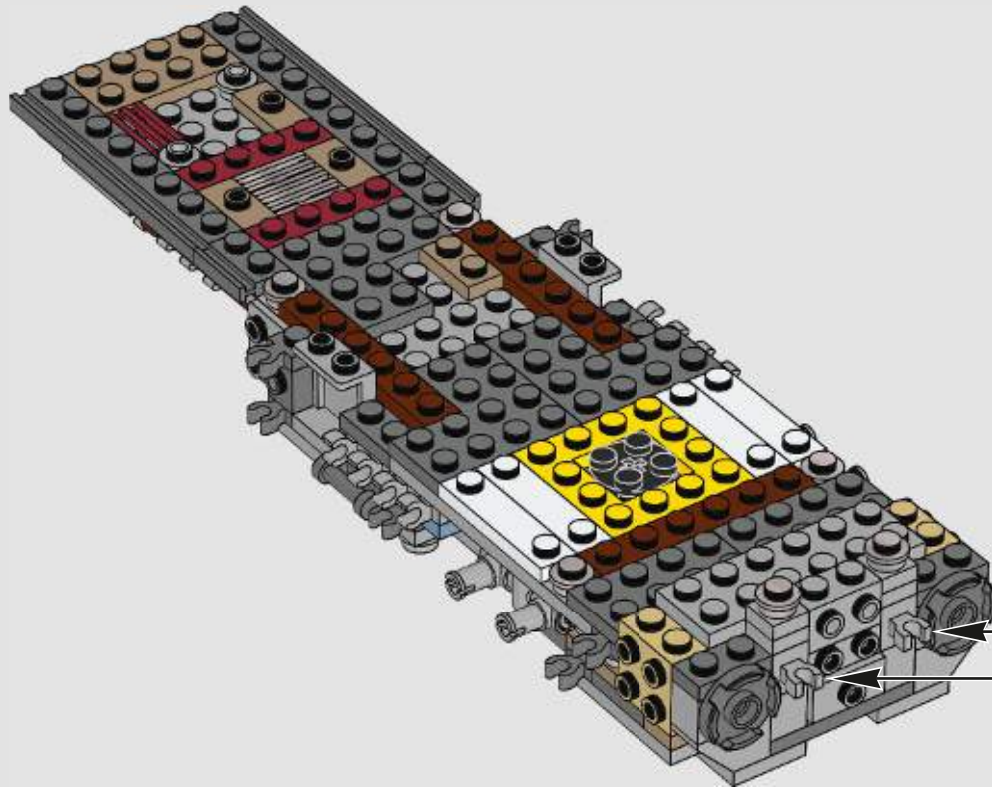

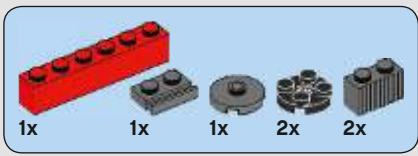

45

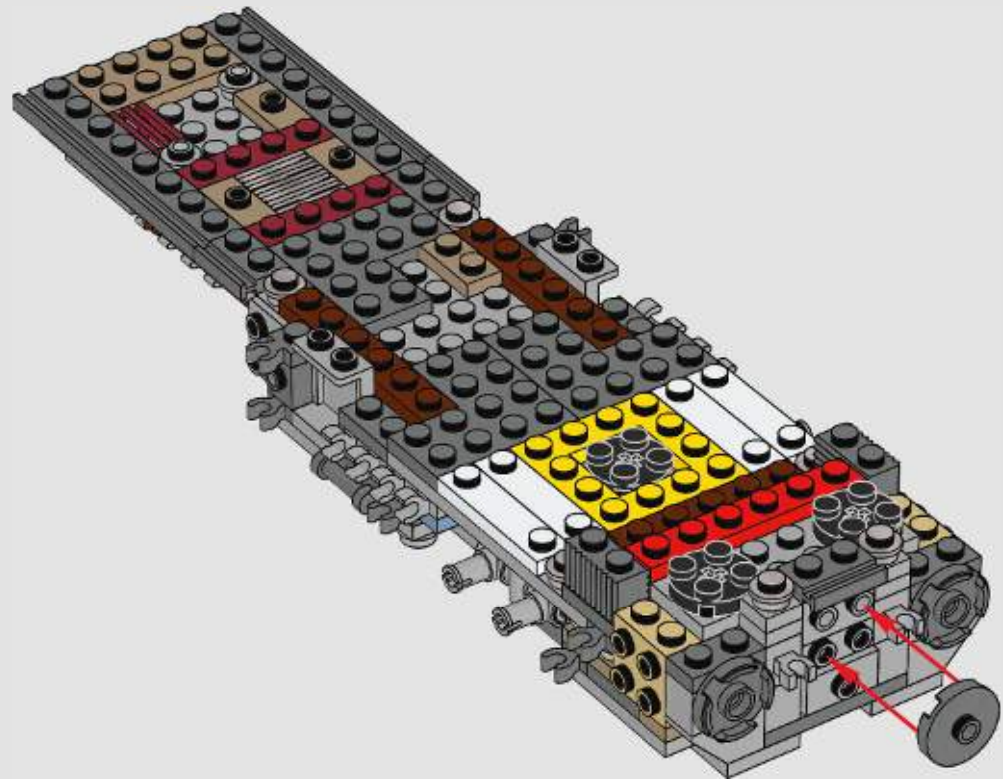



46

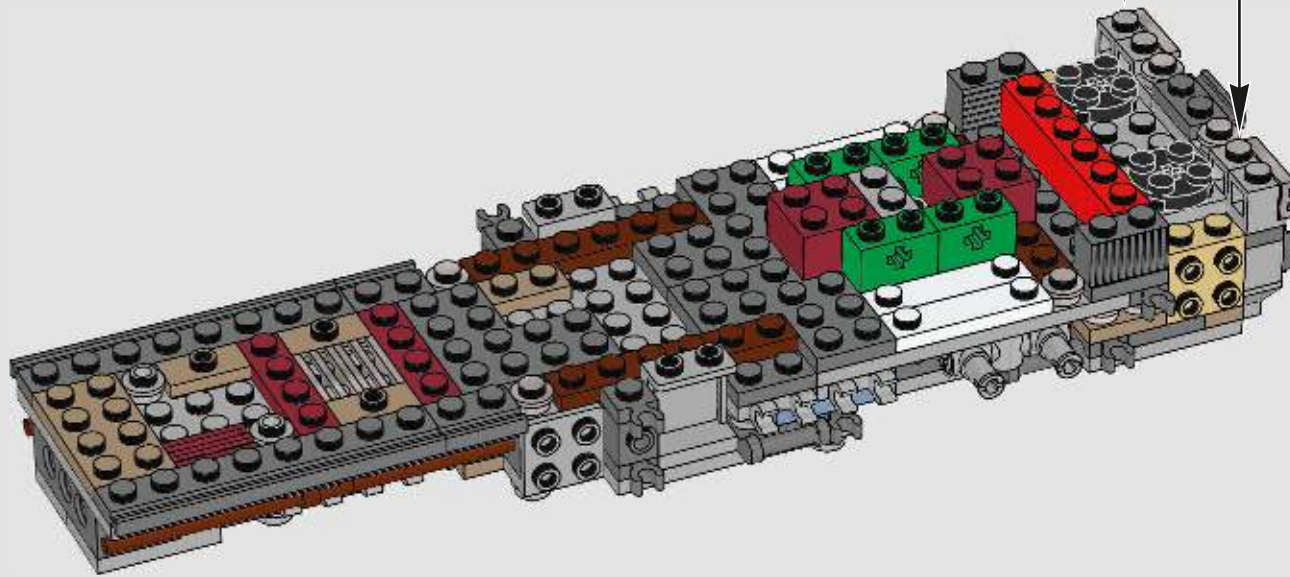
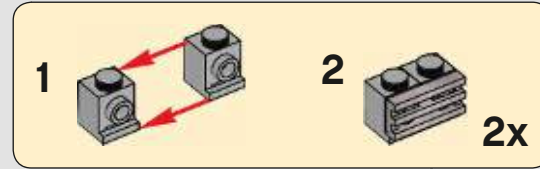

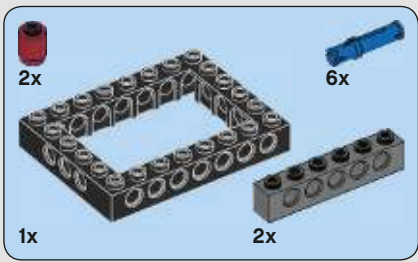

47

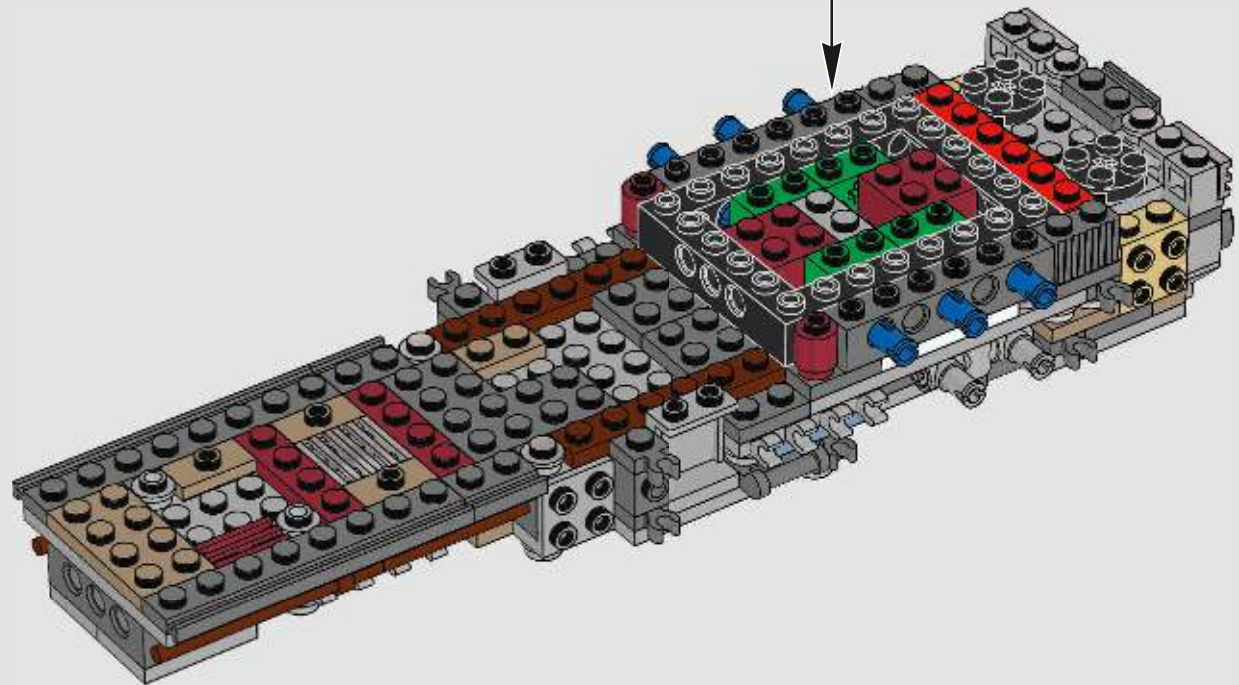
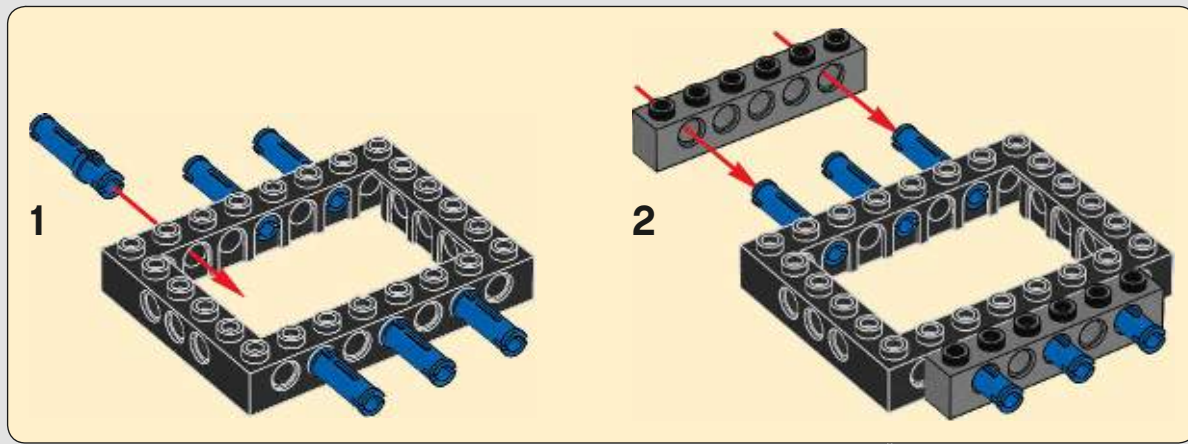

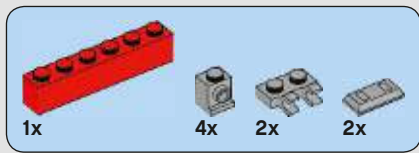

48

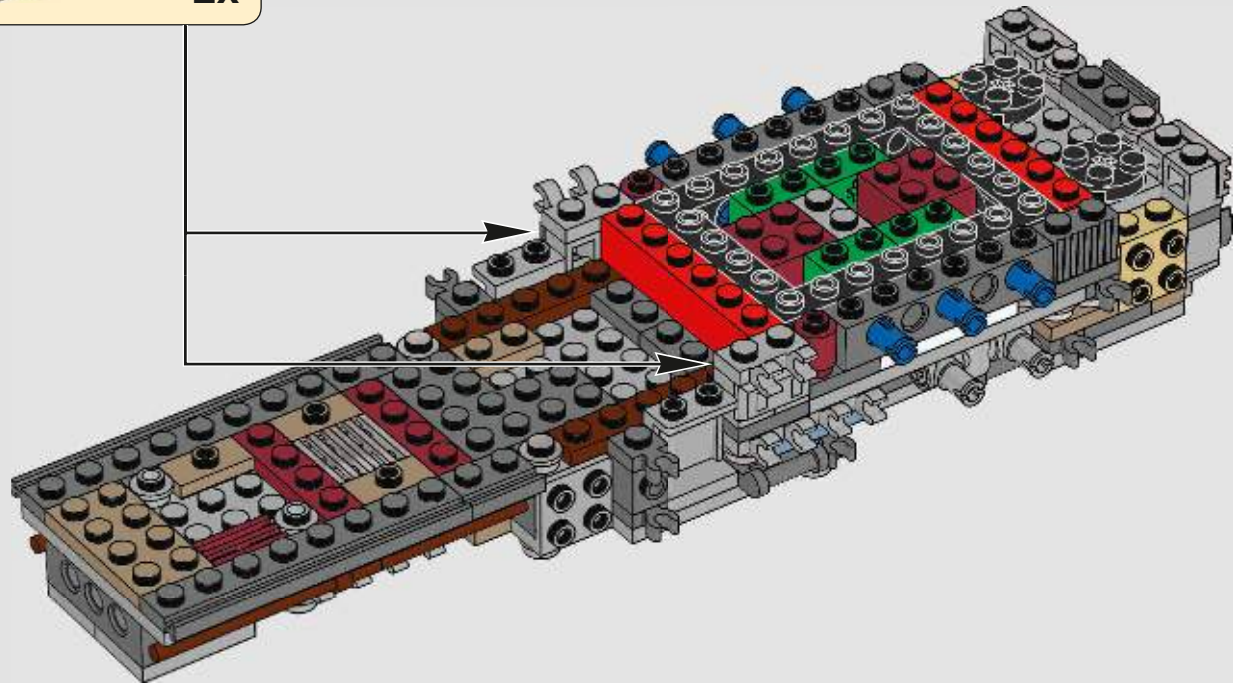
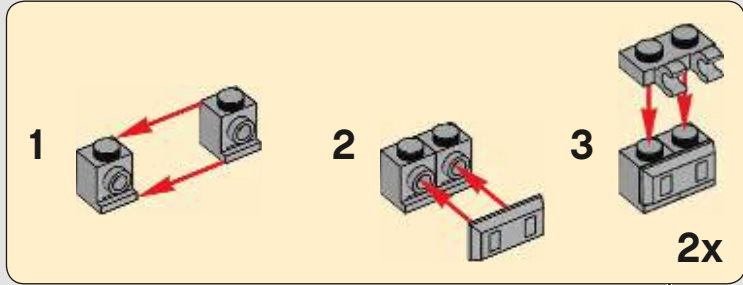



49

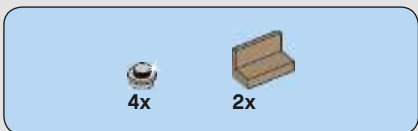
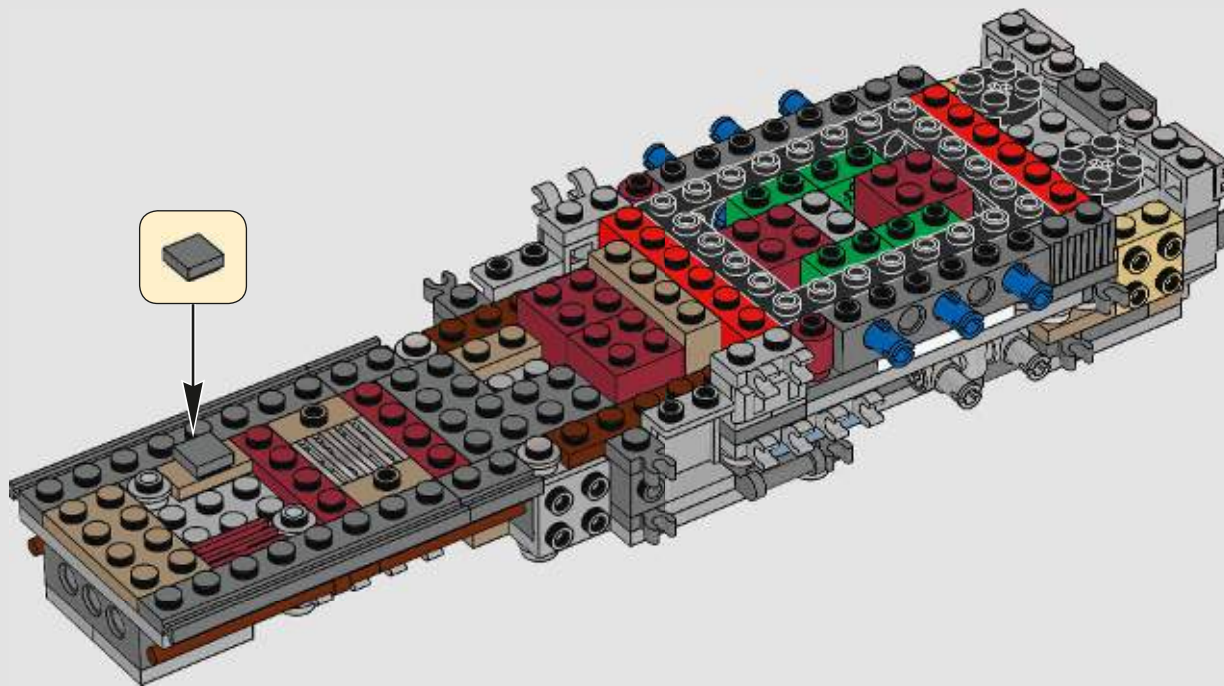

50

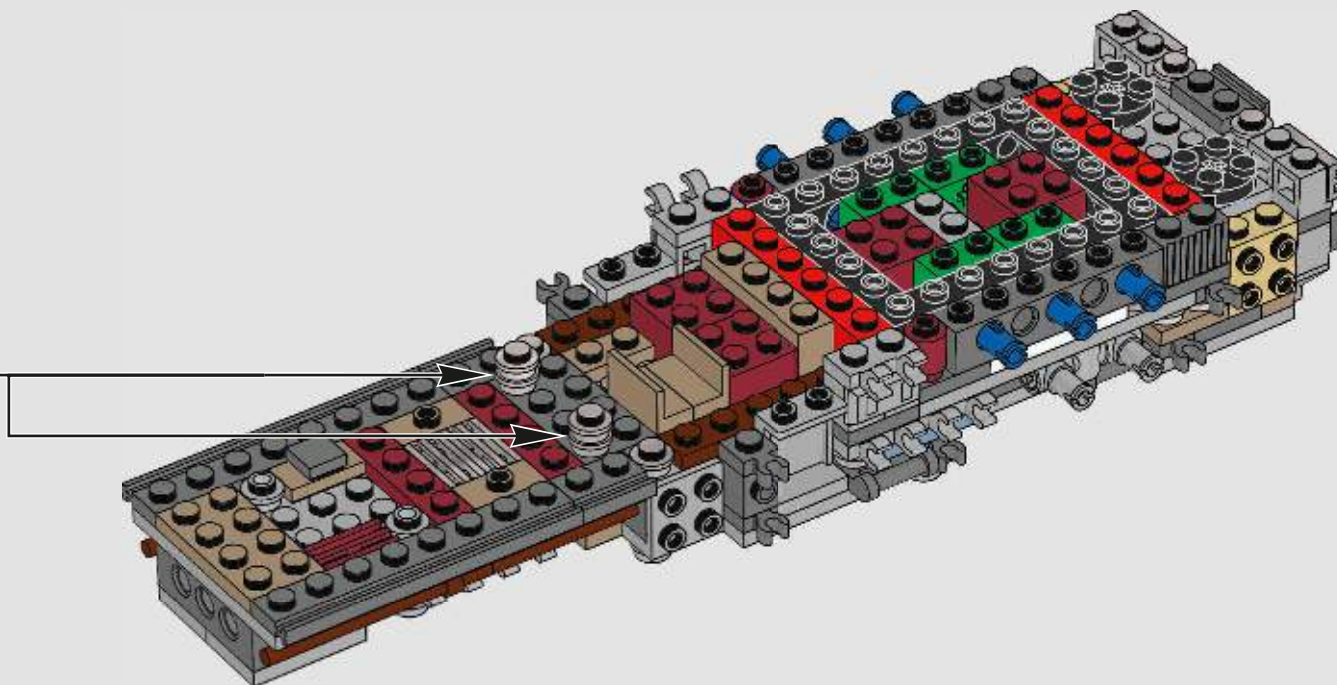
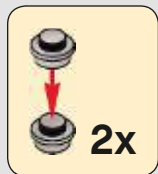

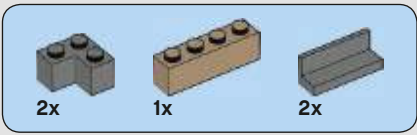

51

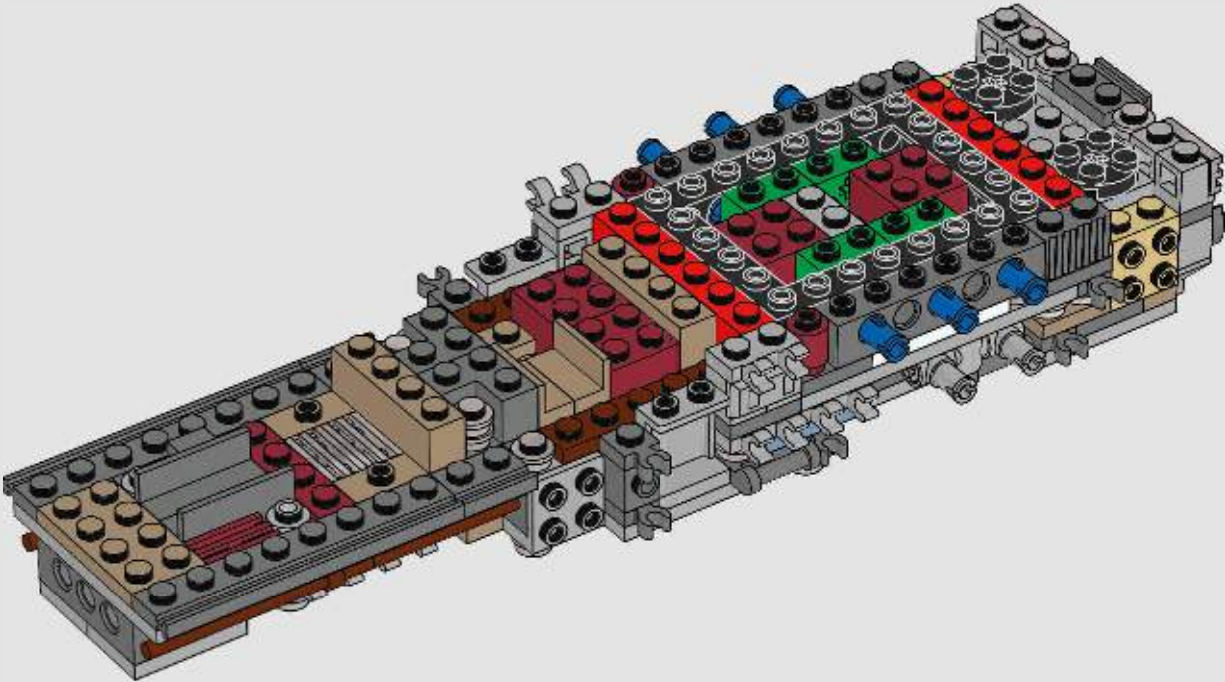

52

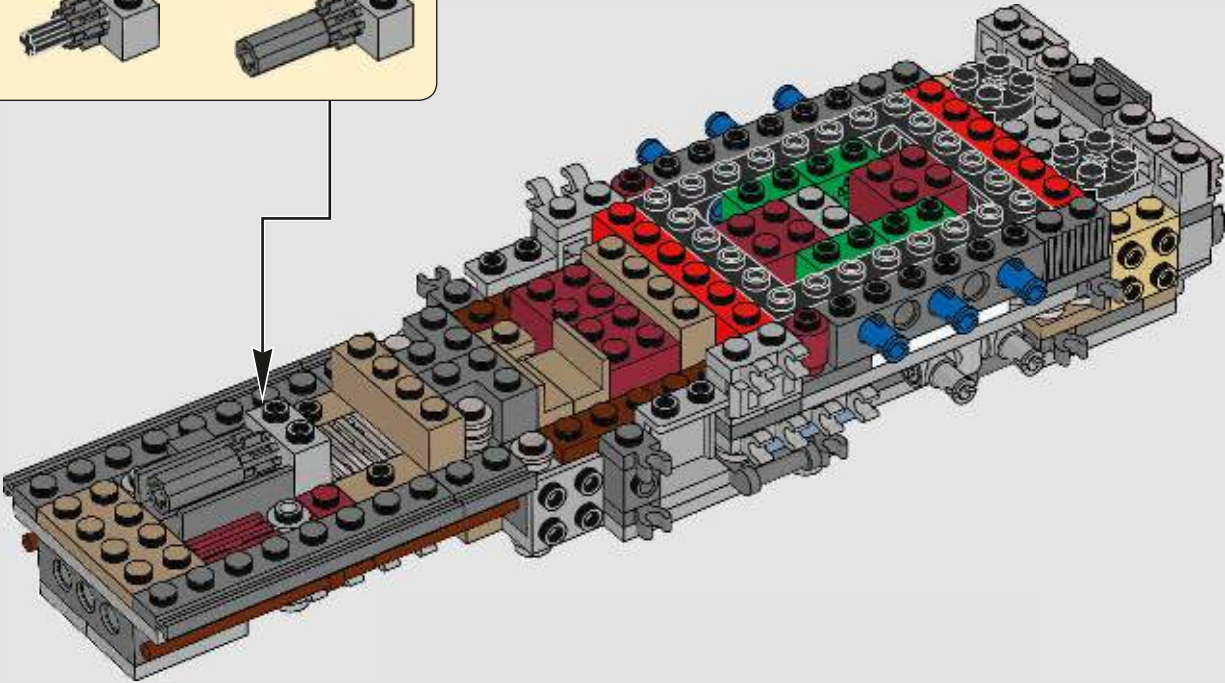
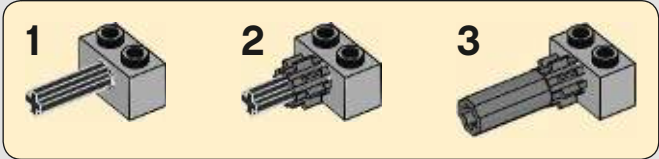

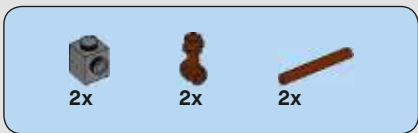

53

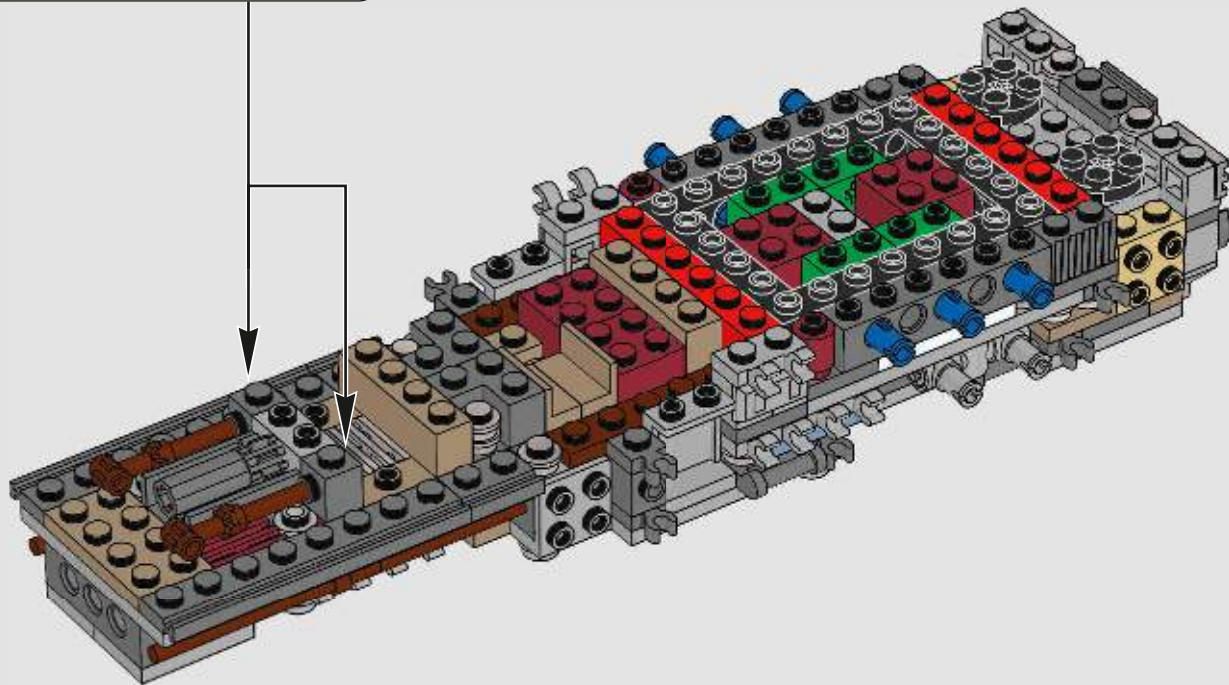

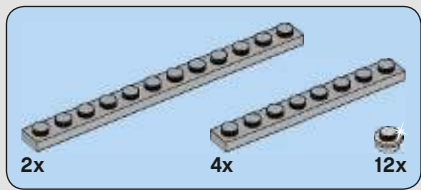

54

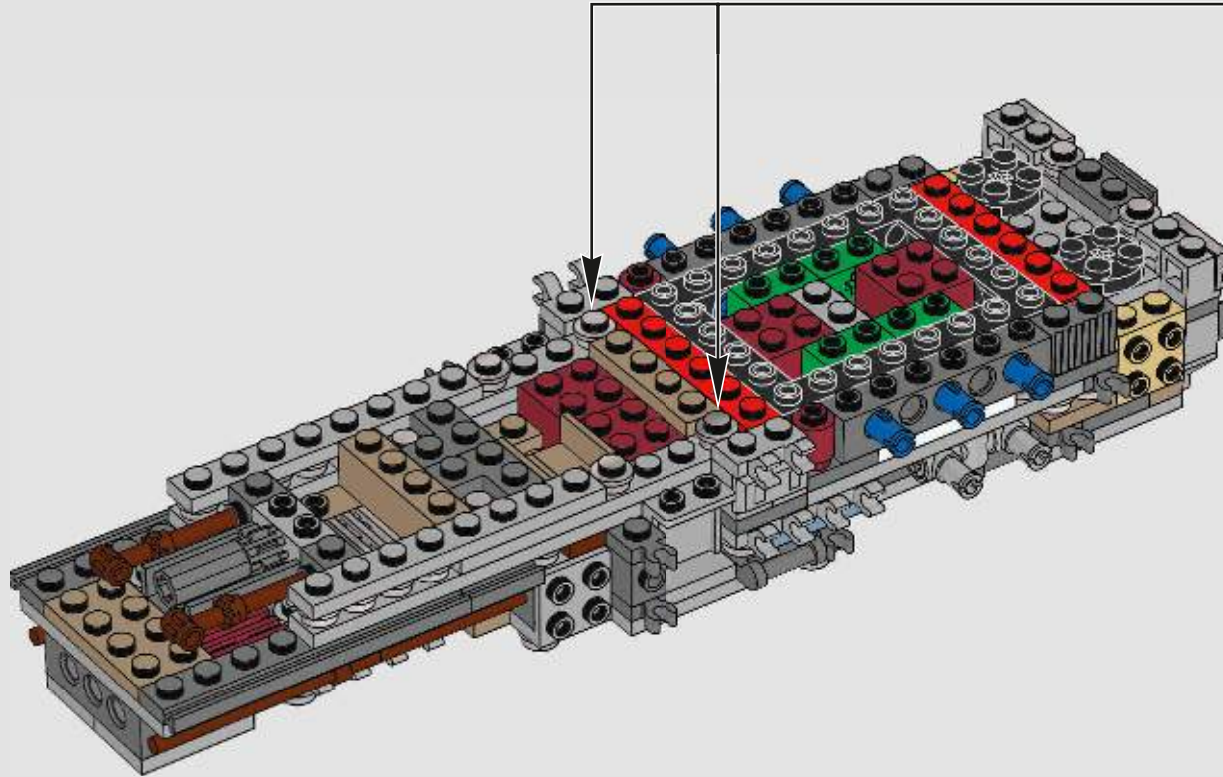
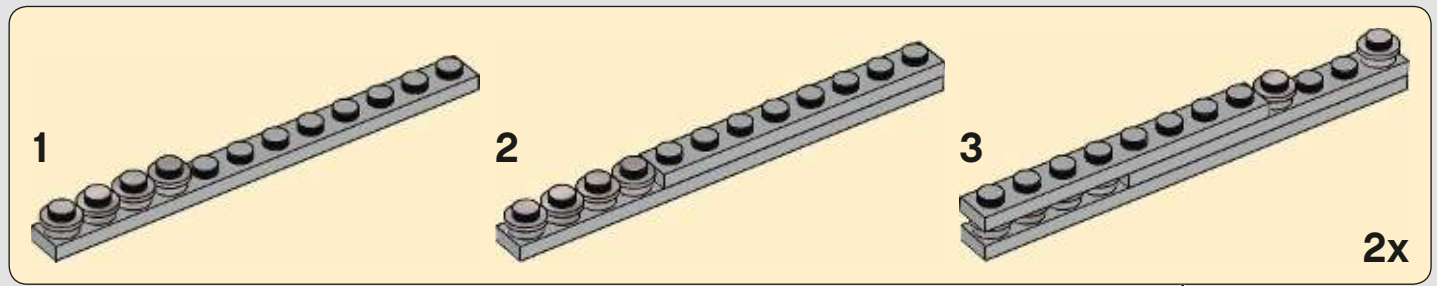

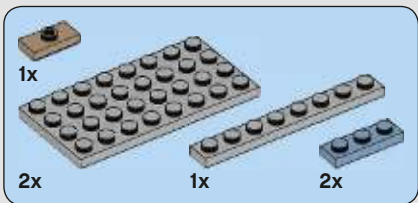

55

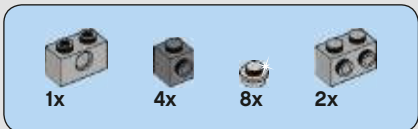
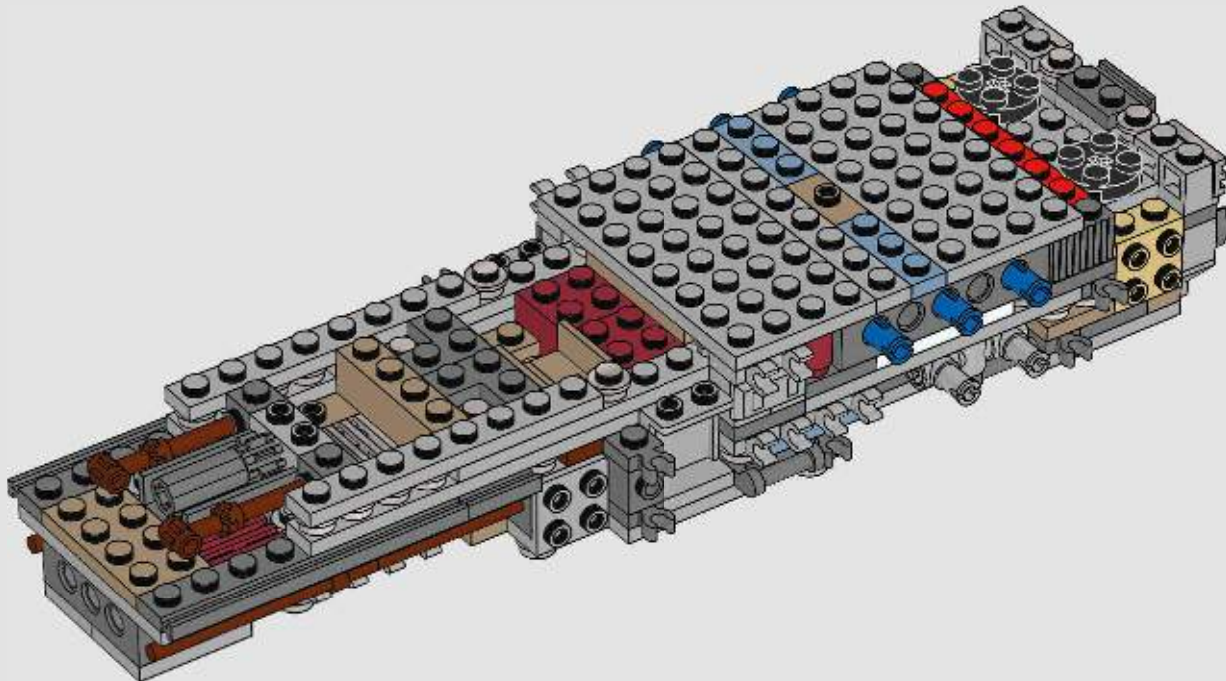

56

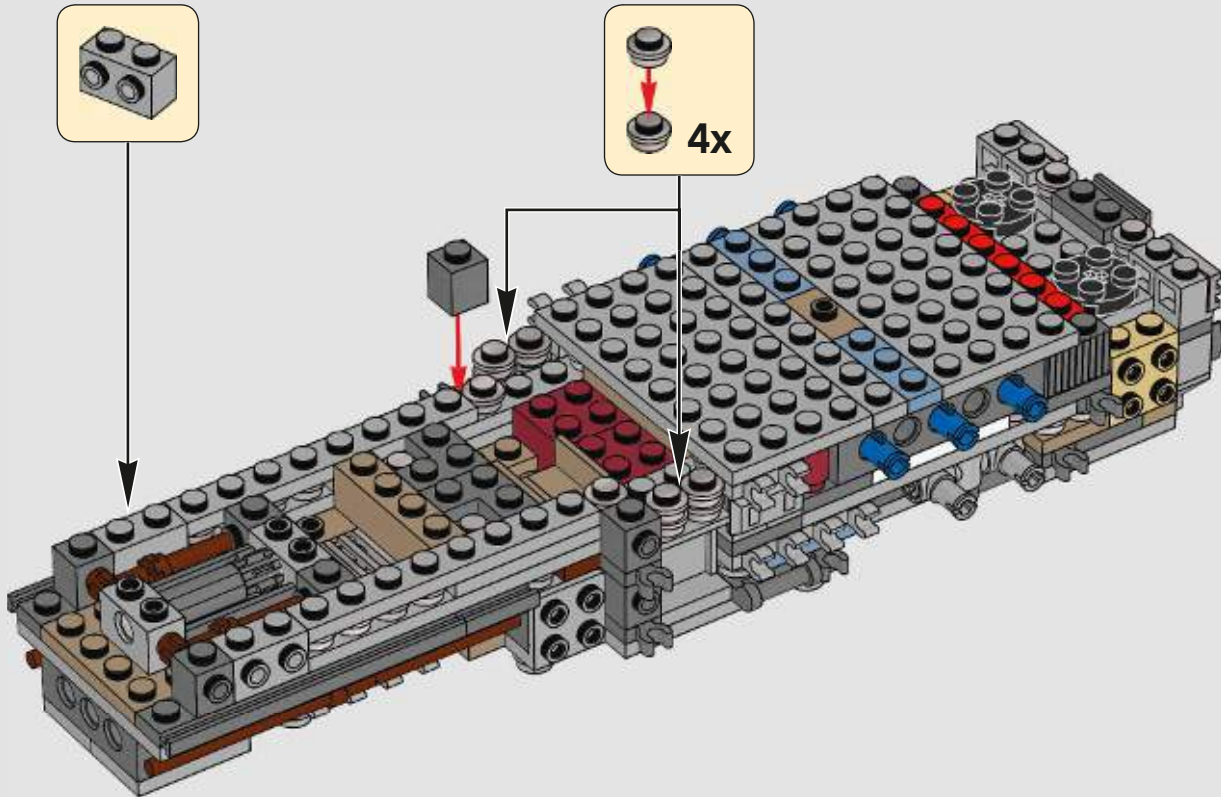

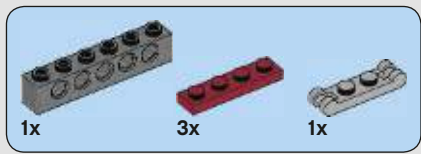

57

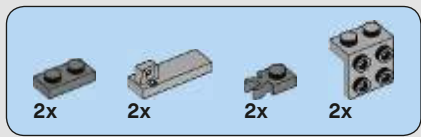
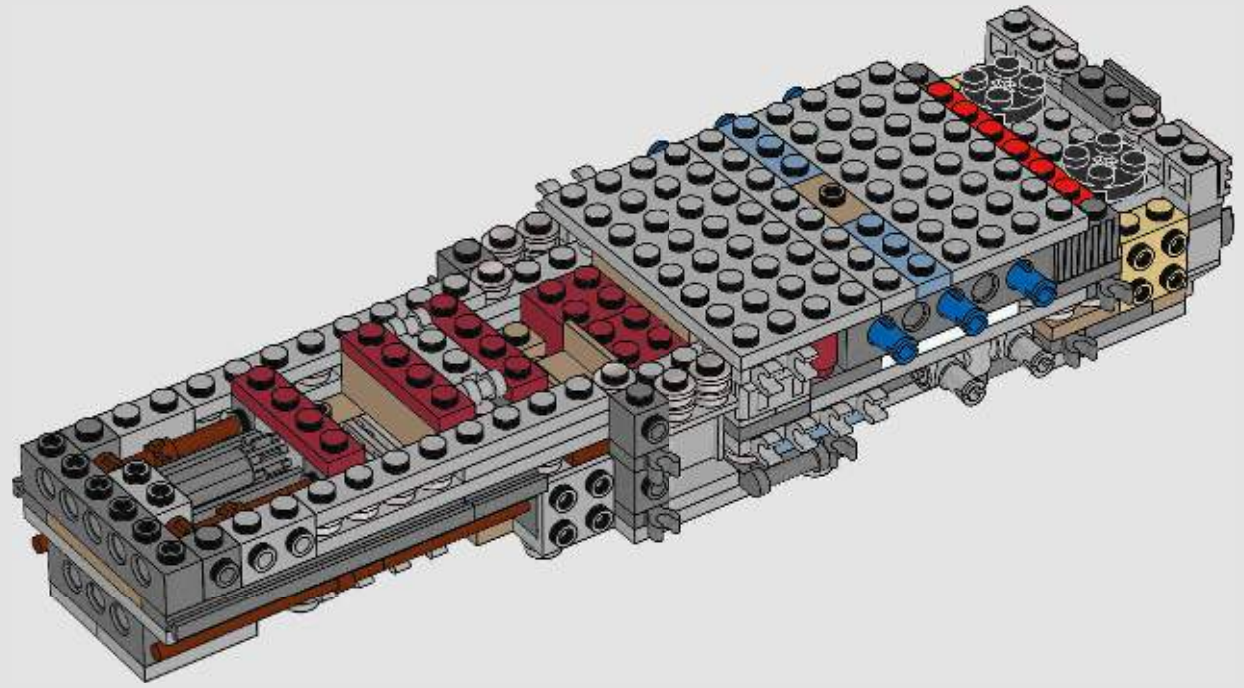

58

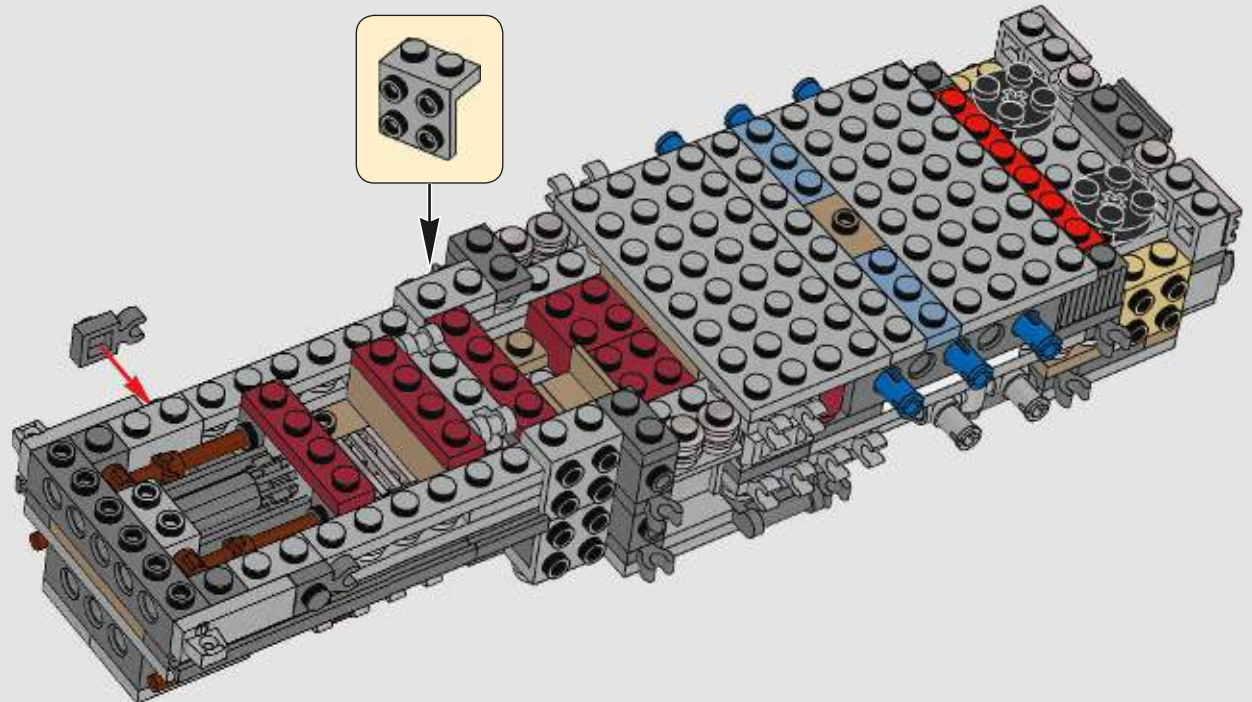

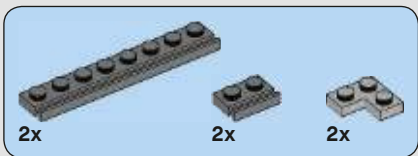

59

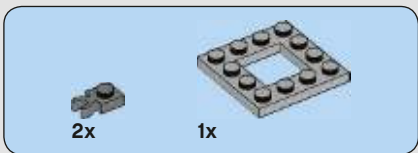
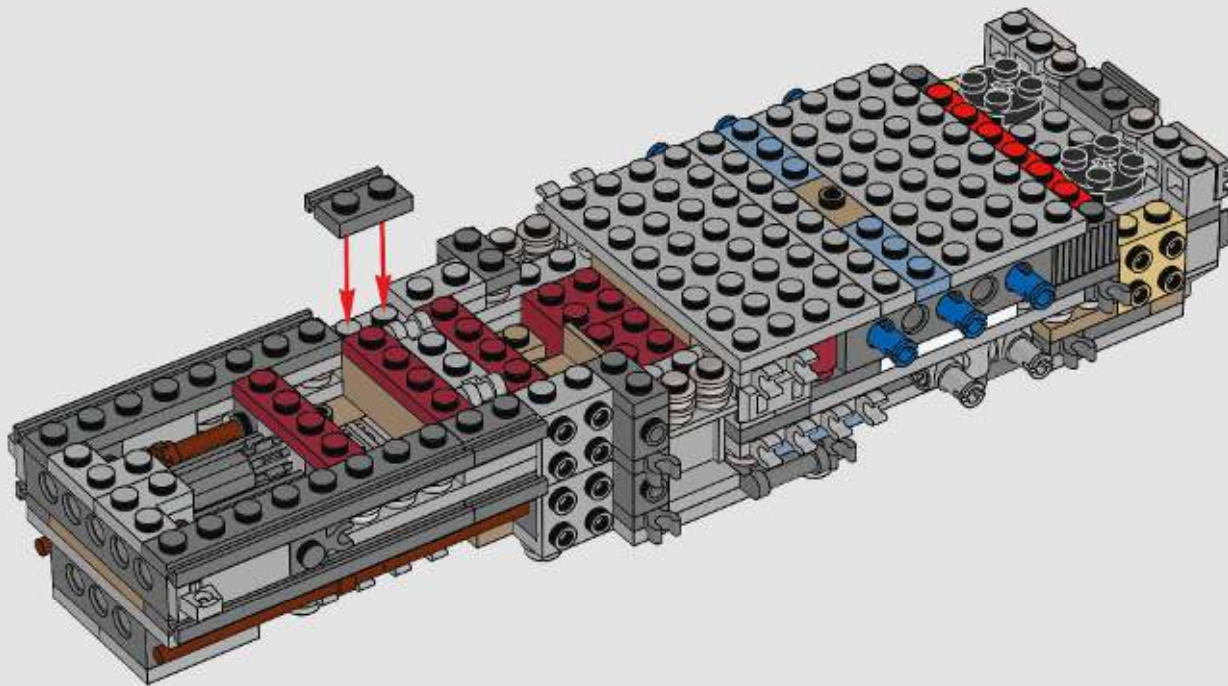

60

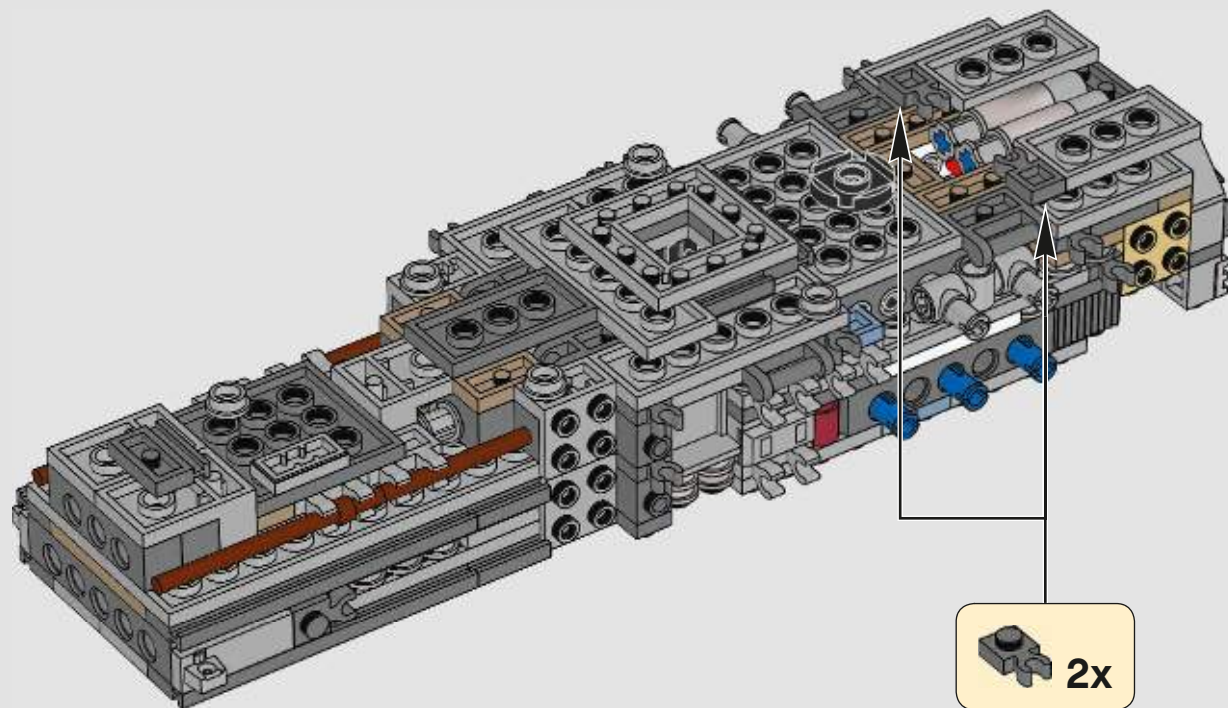
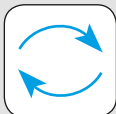

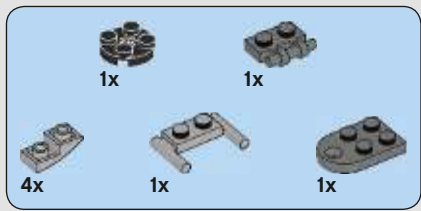

61

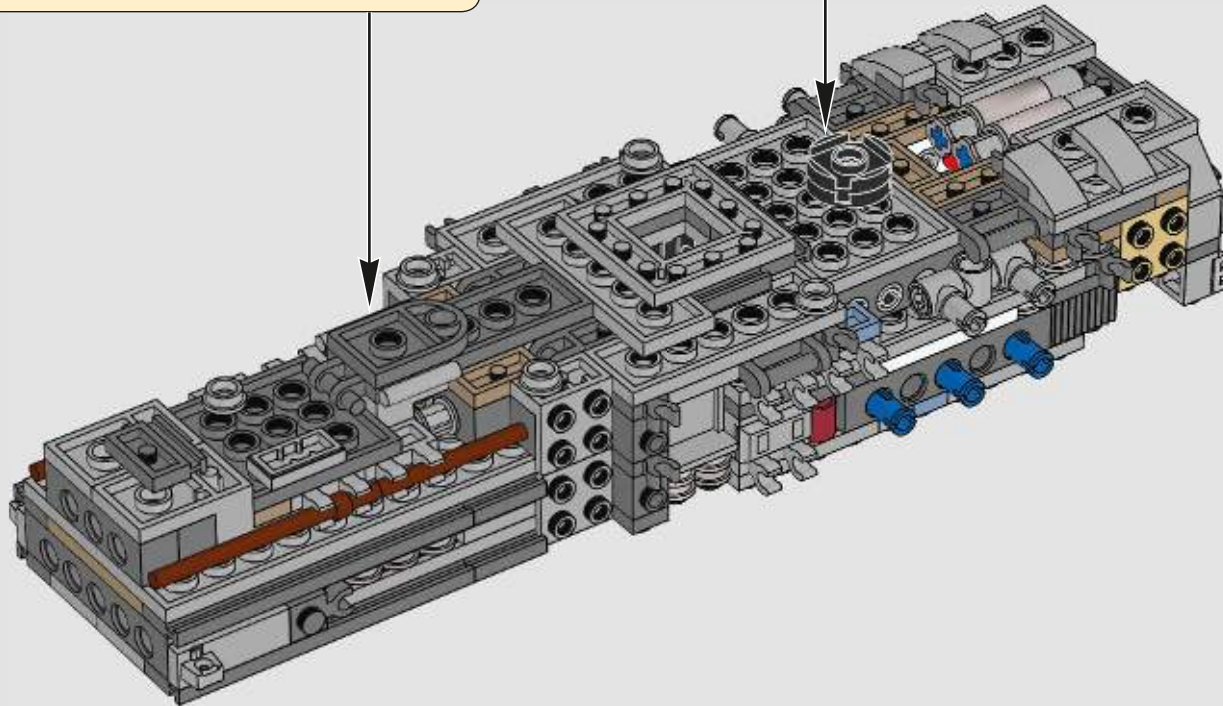
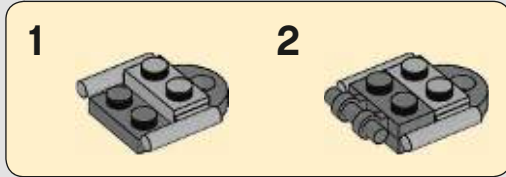

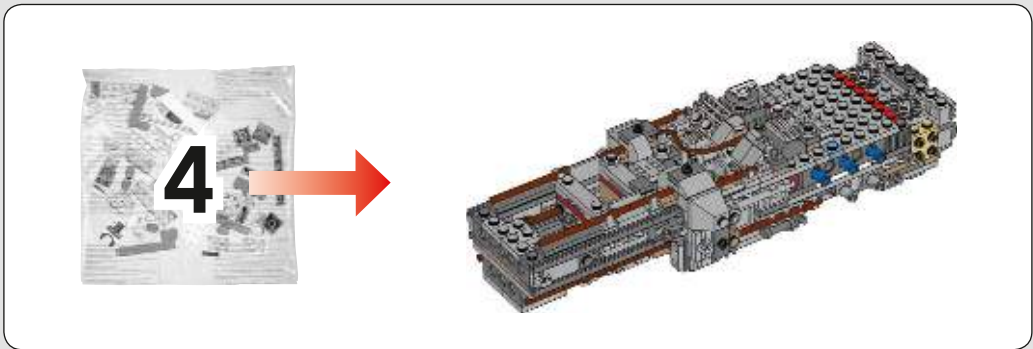

62

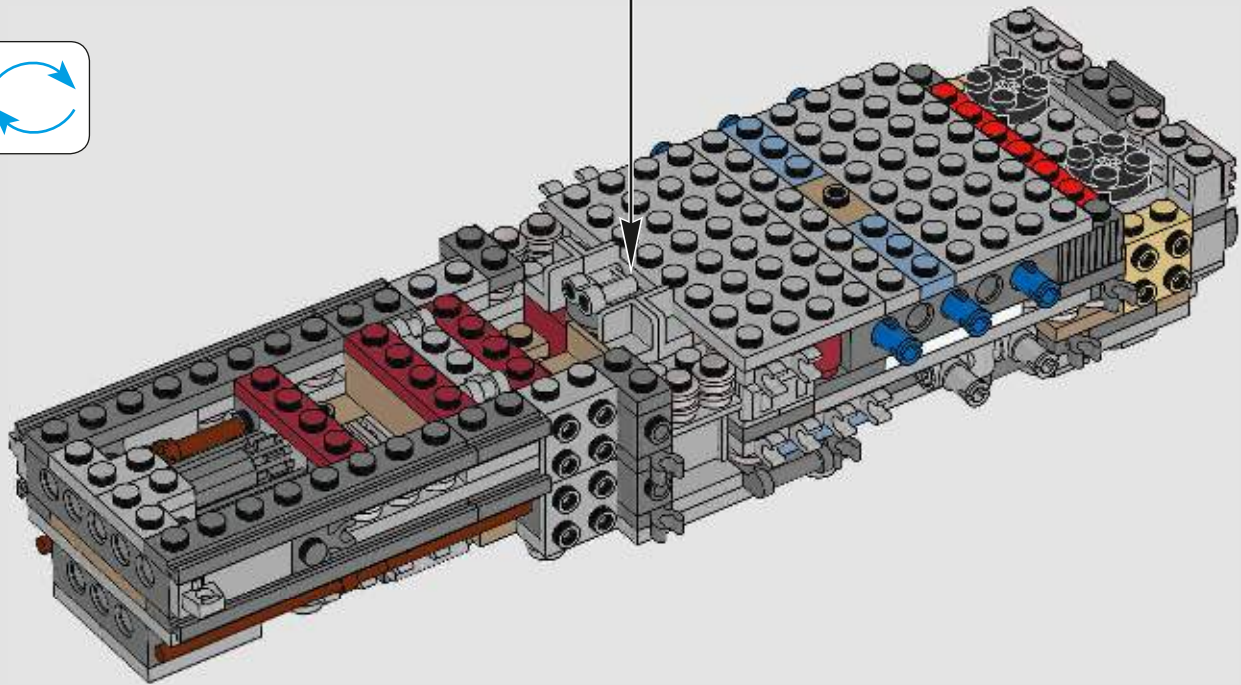
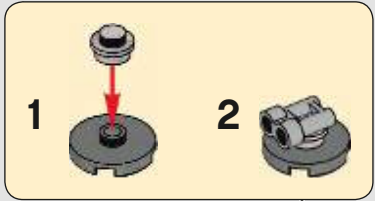



63

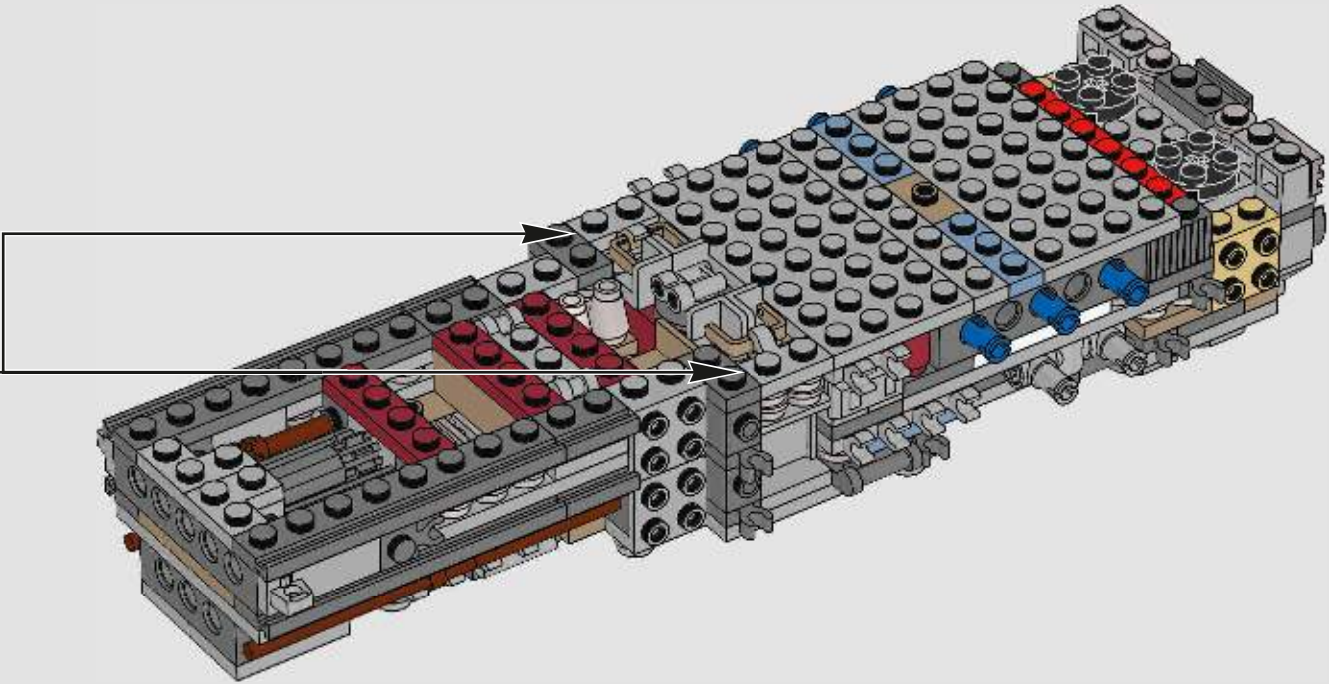
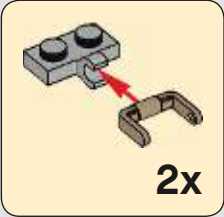

64

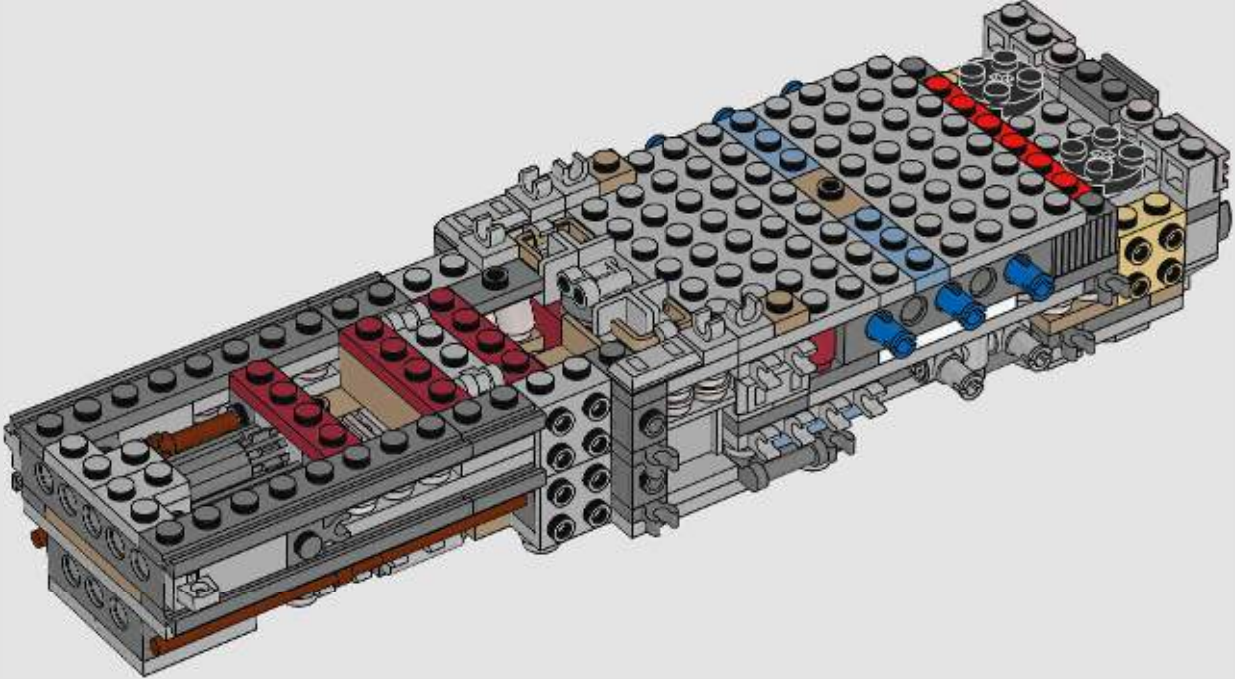



65

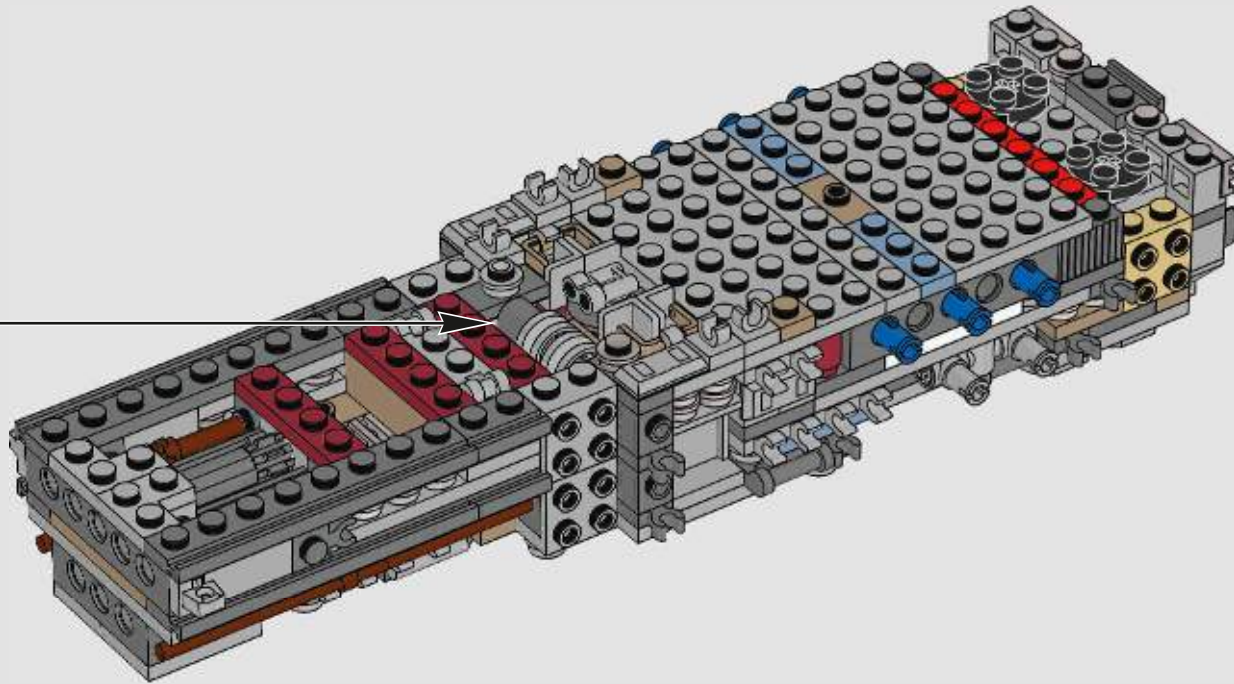
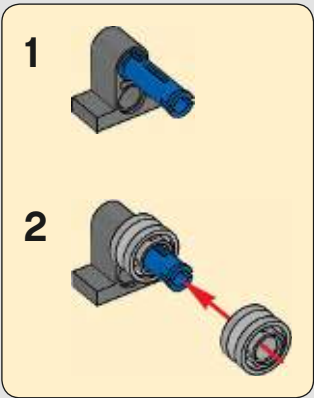

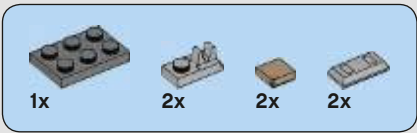

66

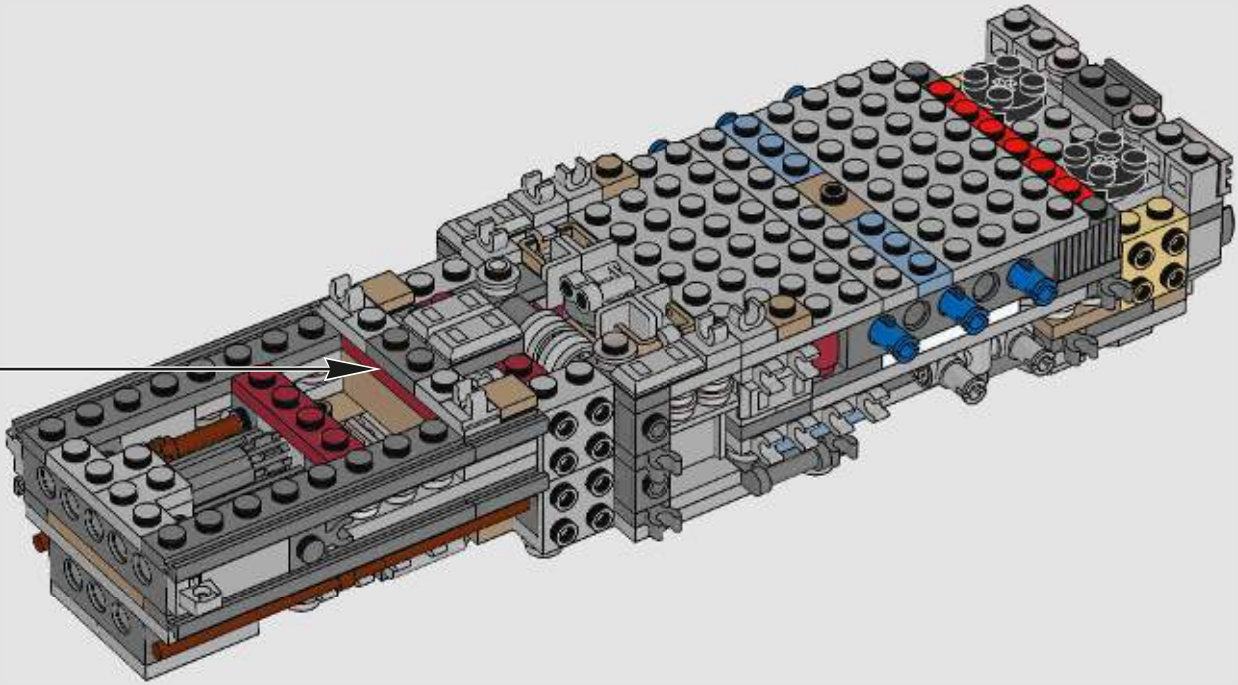
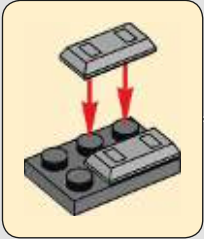

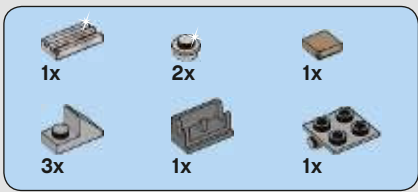

67

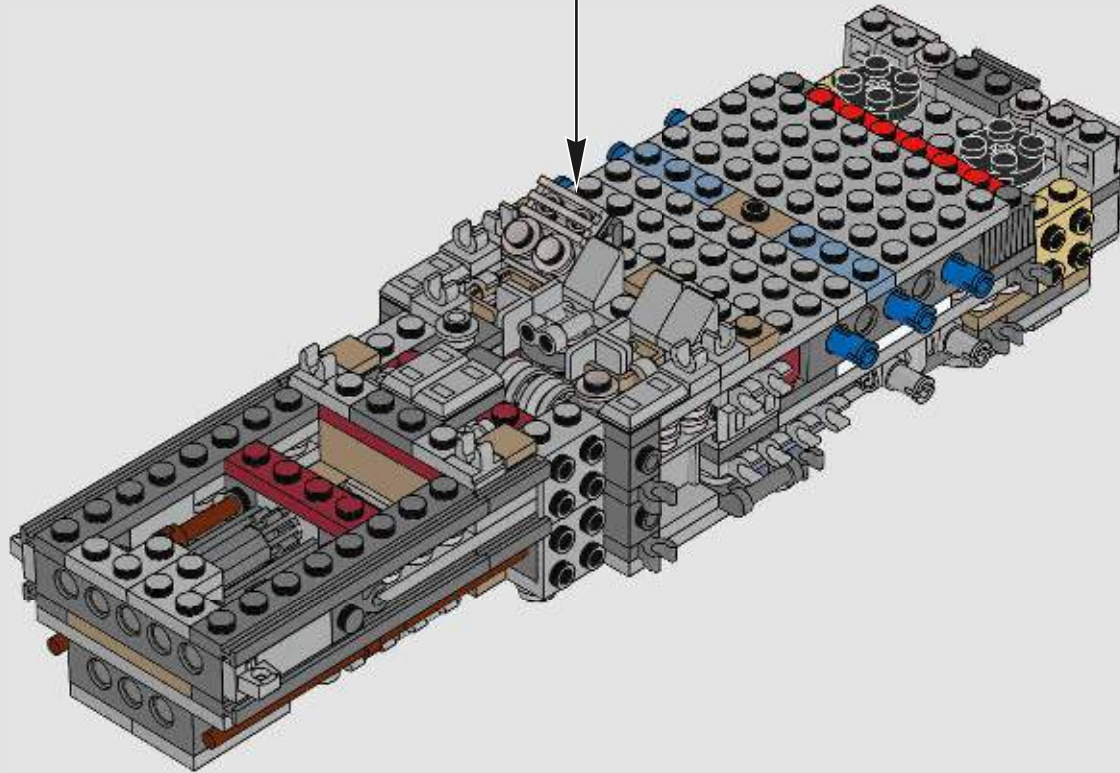
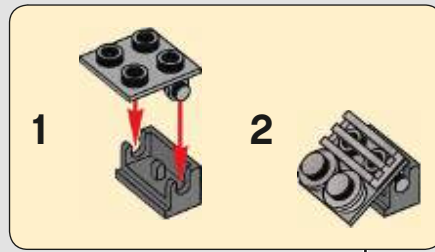

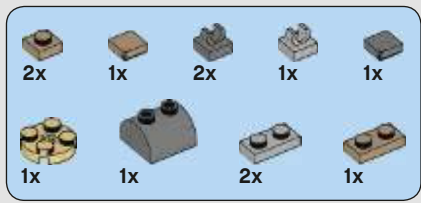

68

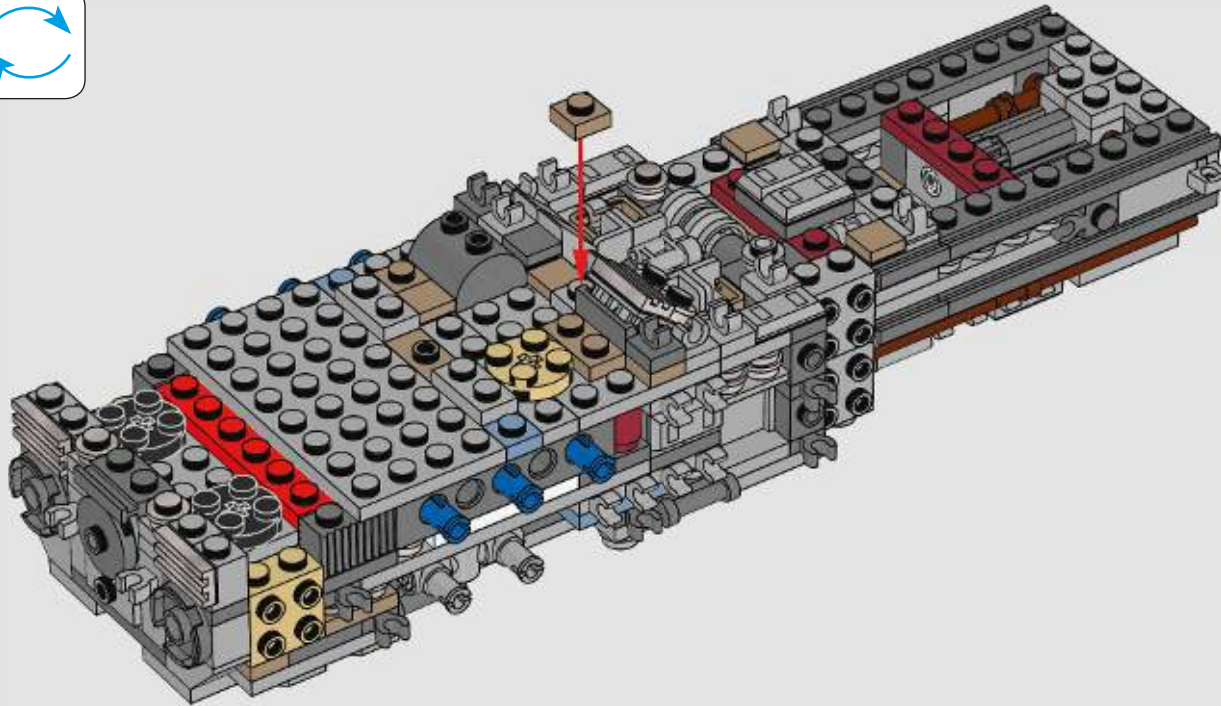



69

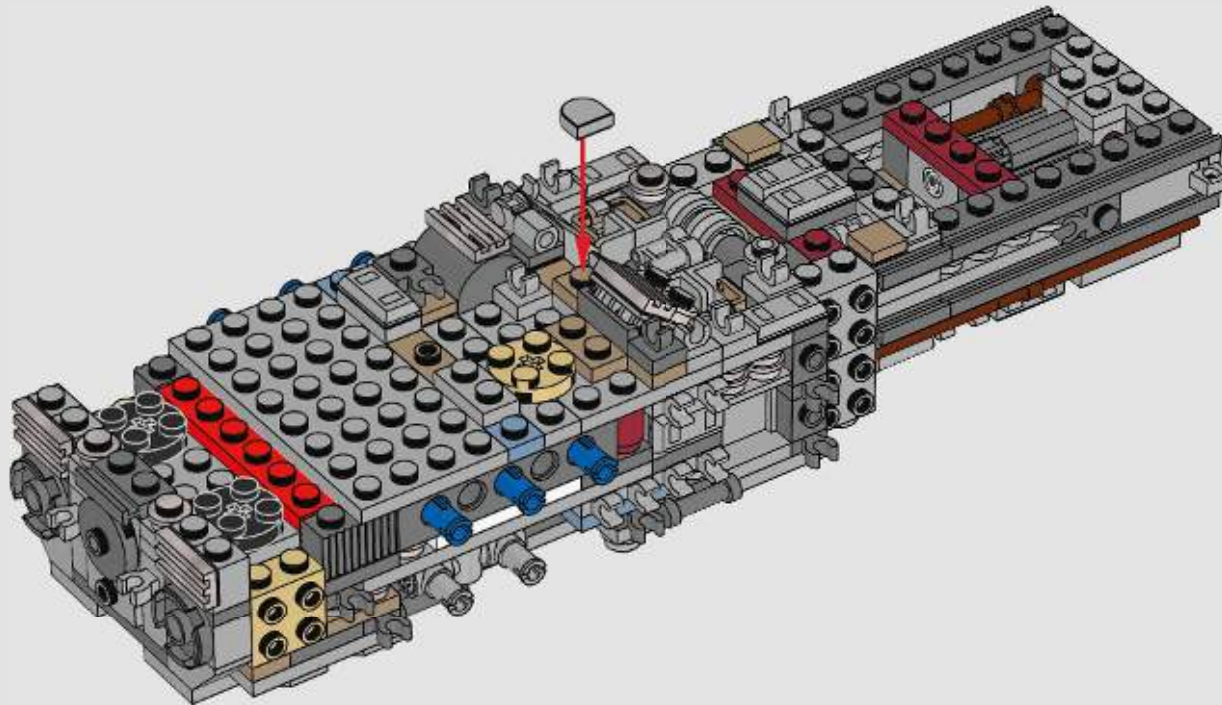

70

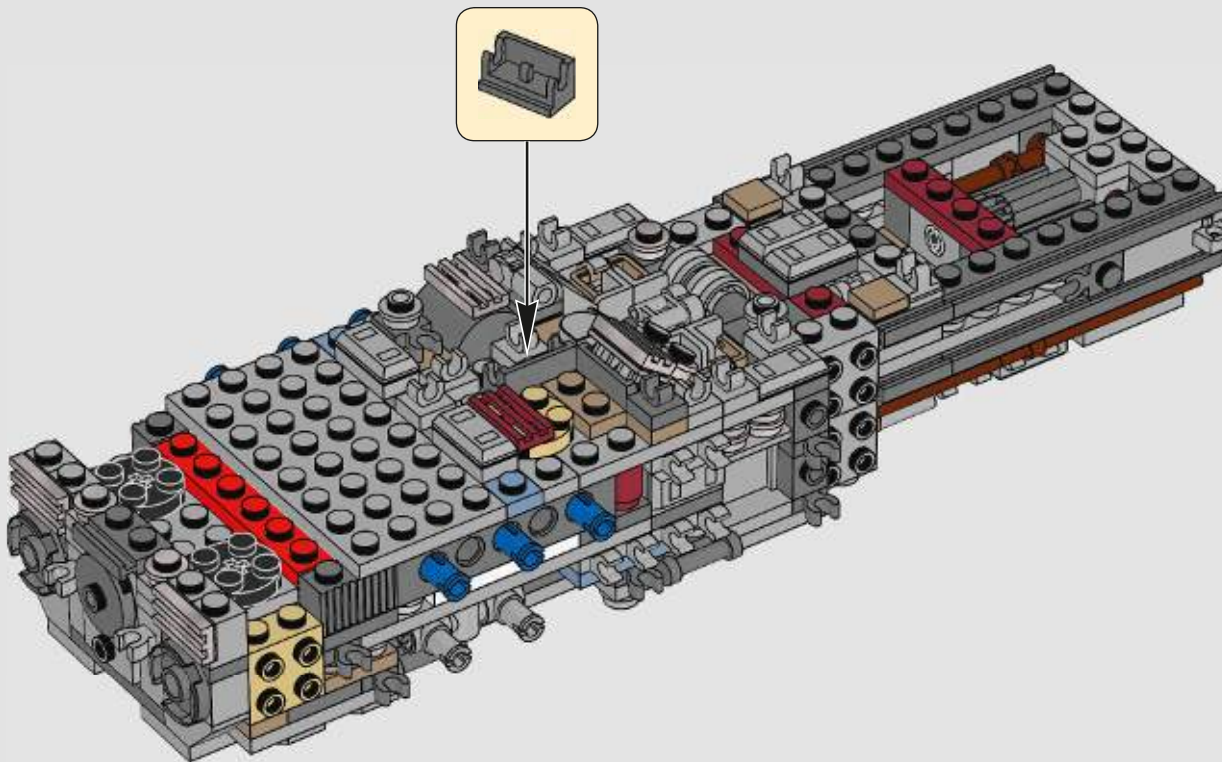

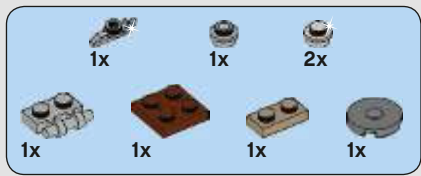

71

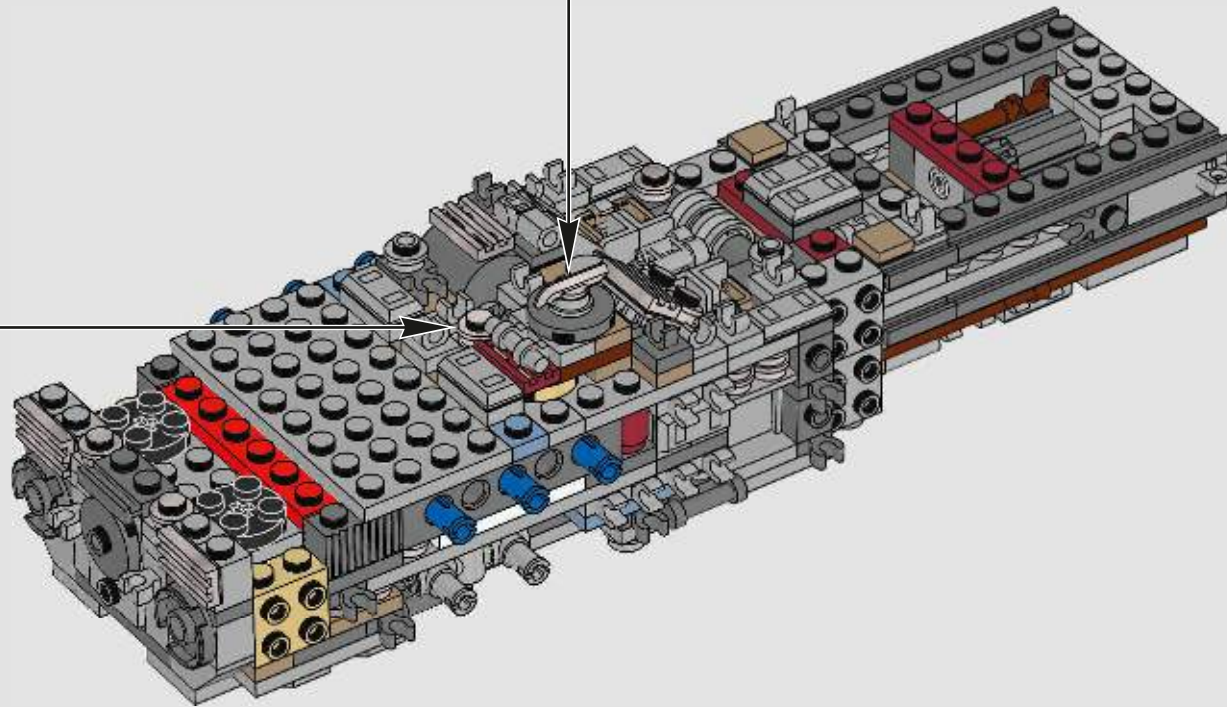
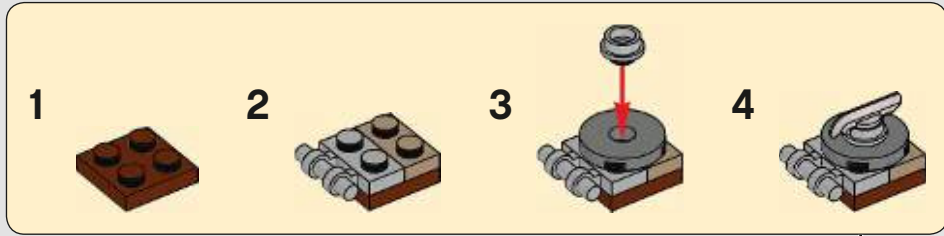



72

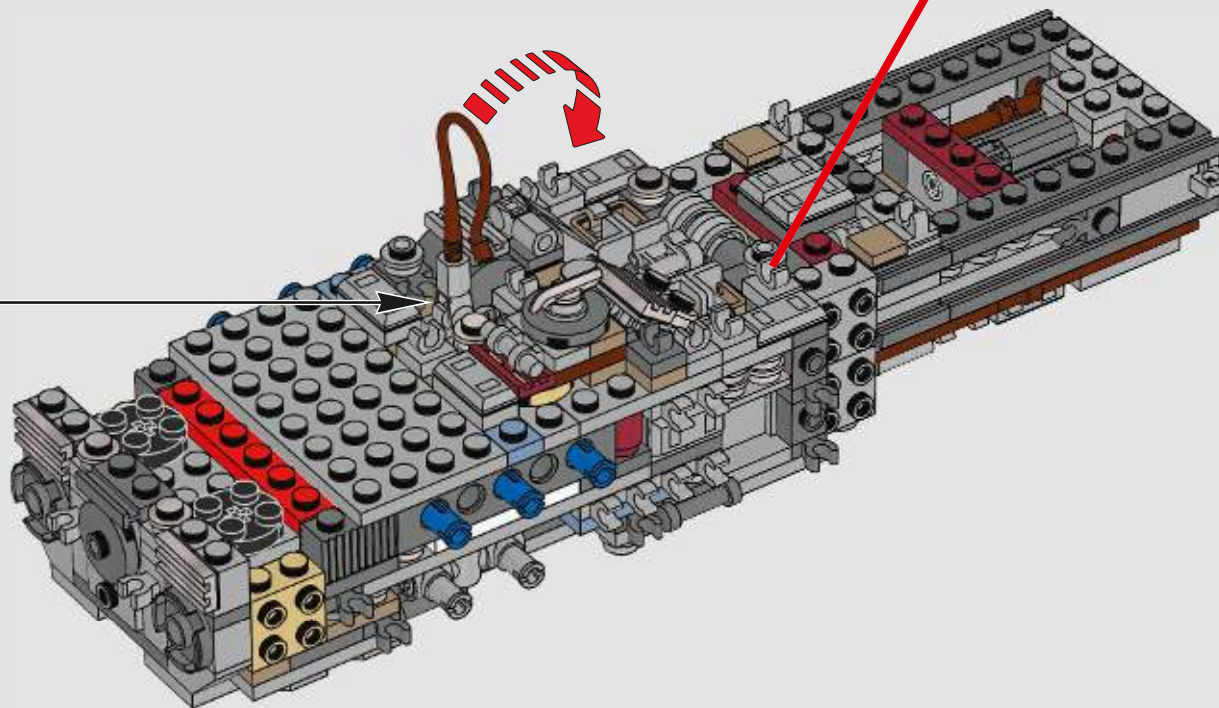
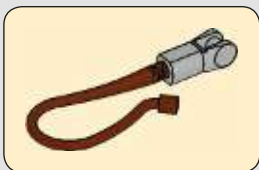
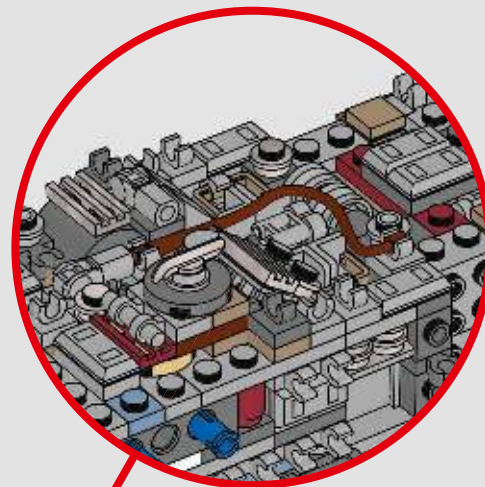

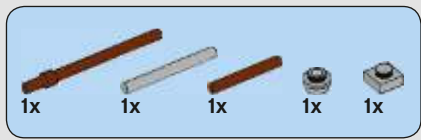

73

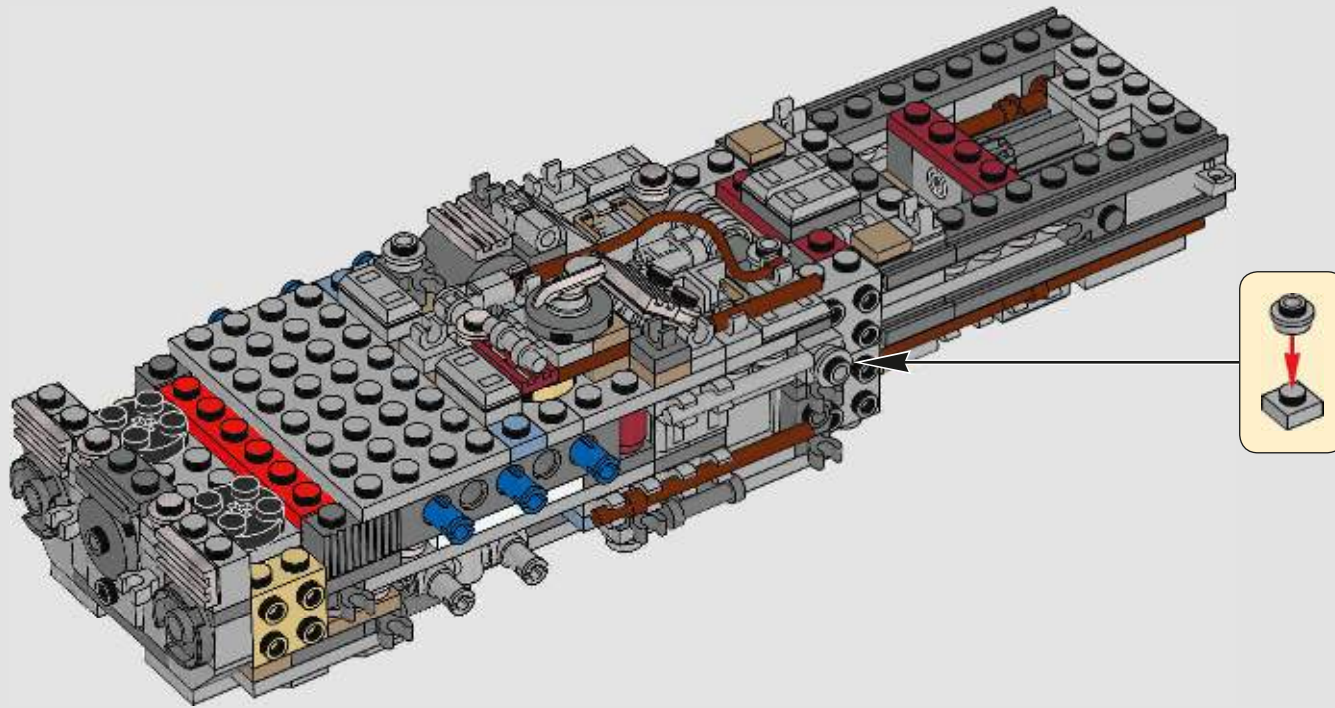

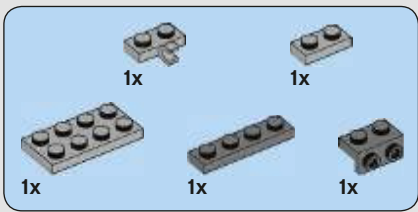

74

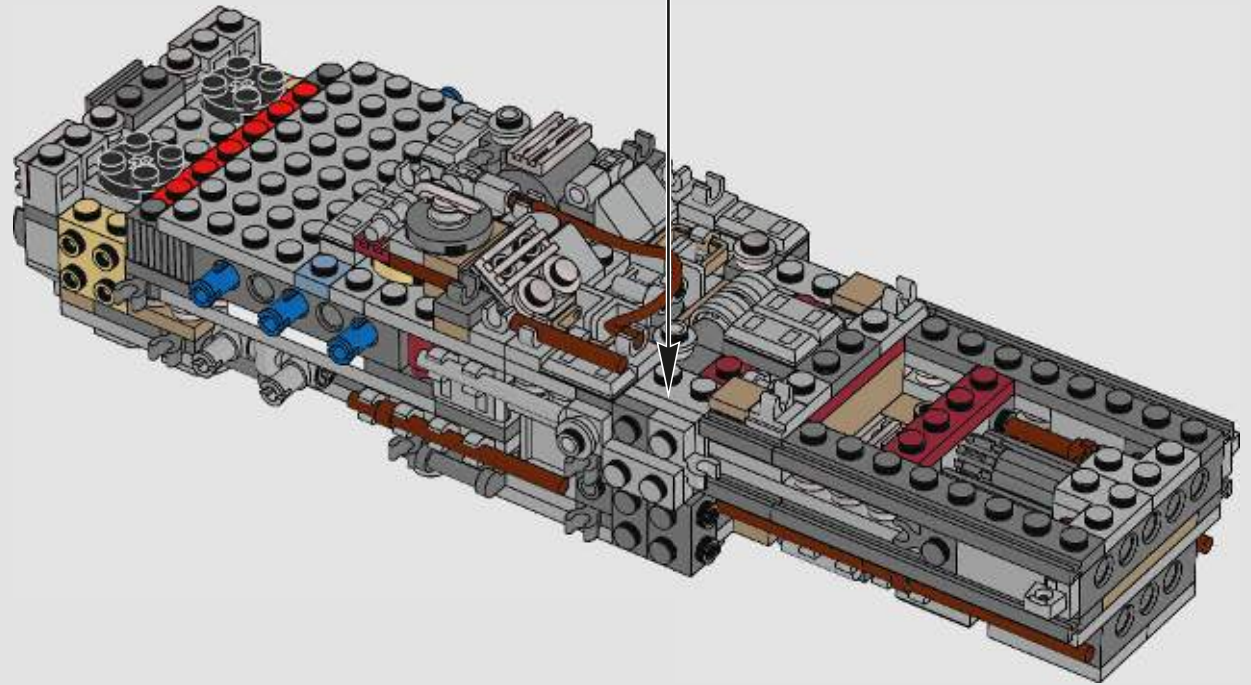
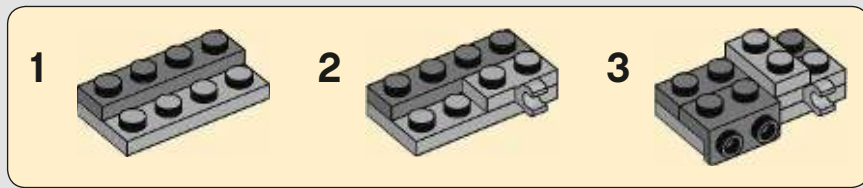



75

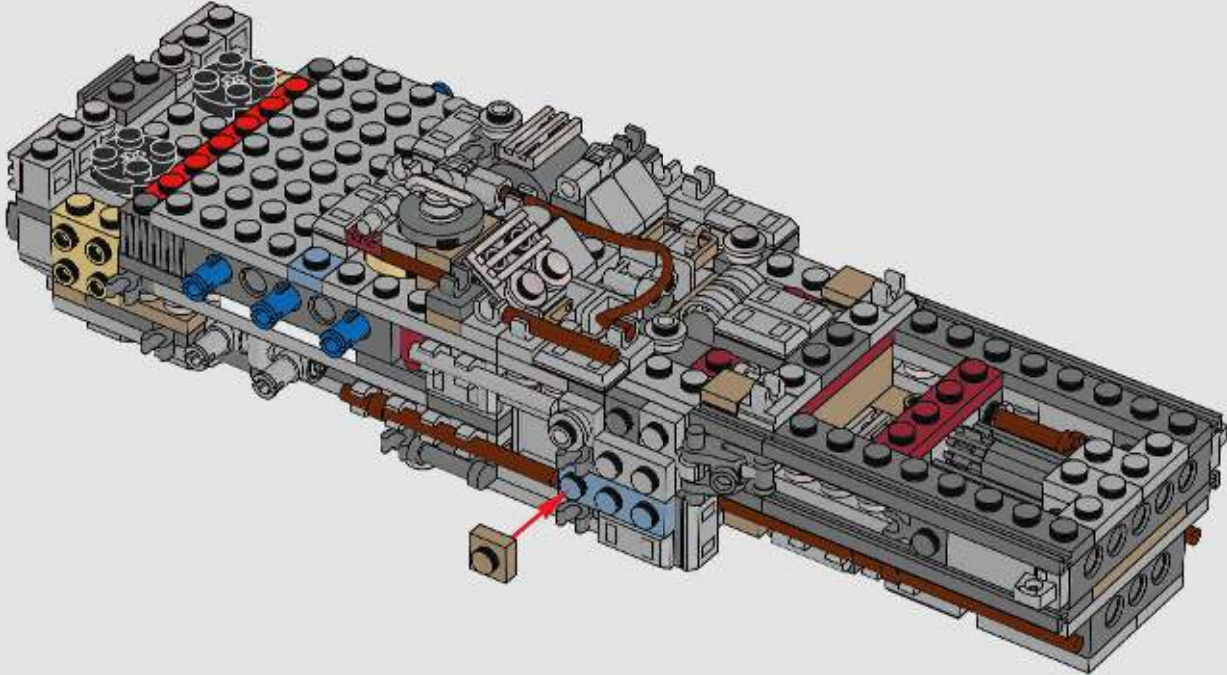



76

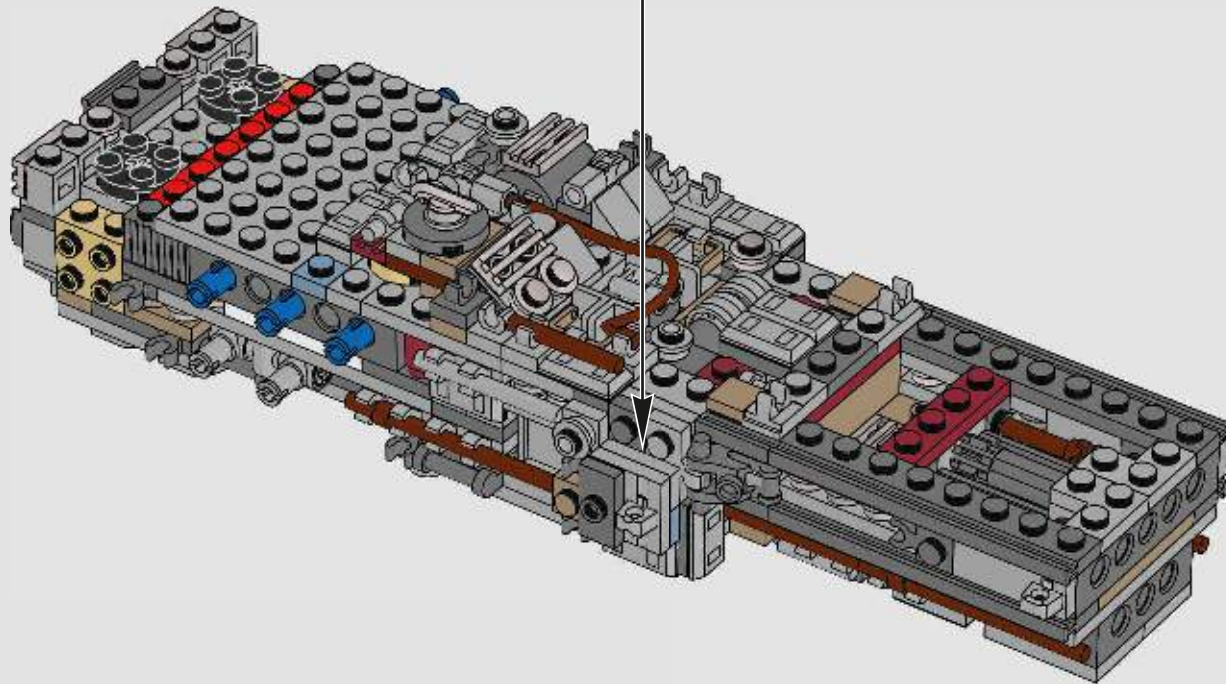
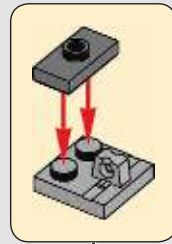



77

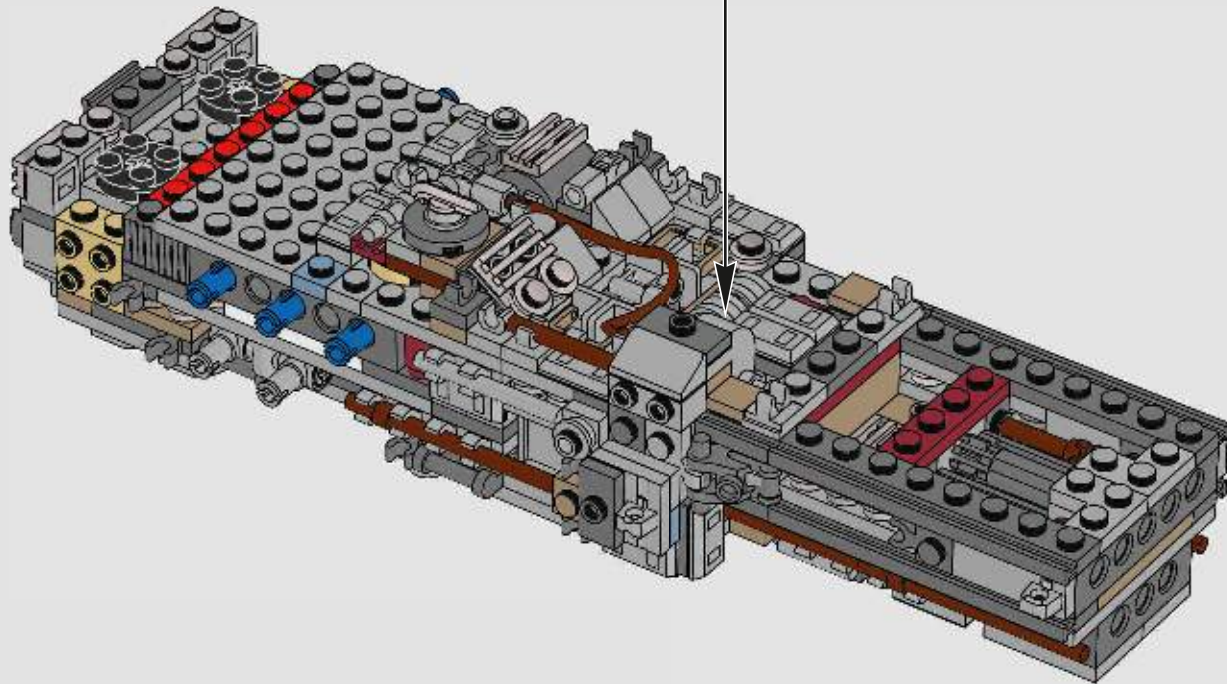
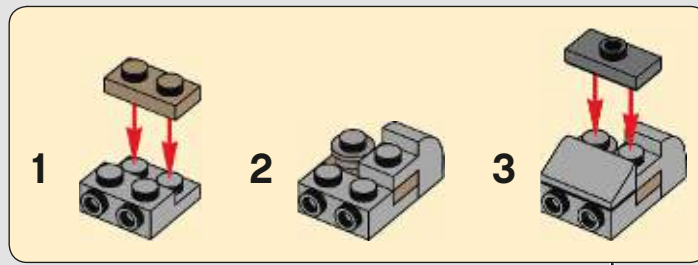

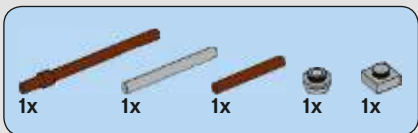

78

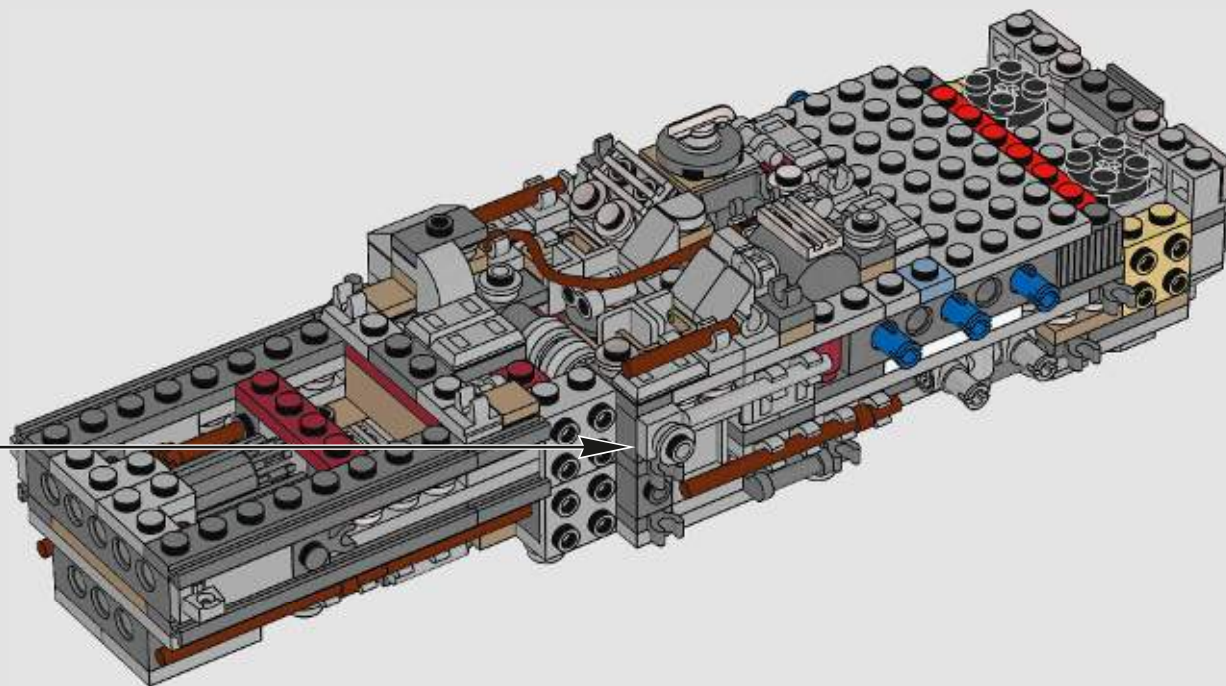
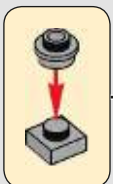
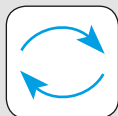

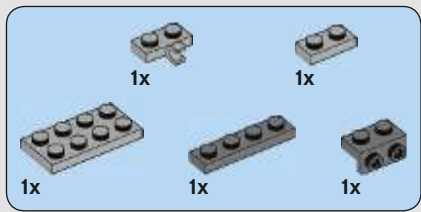

79

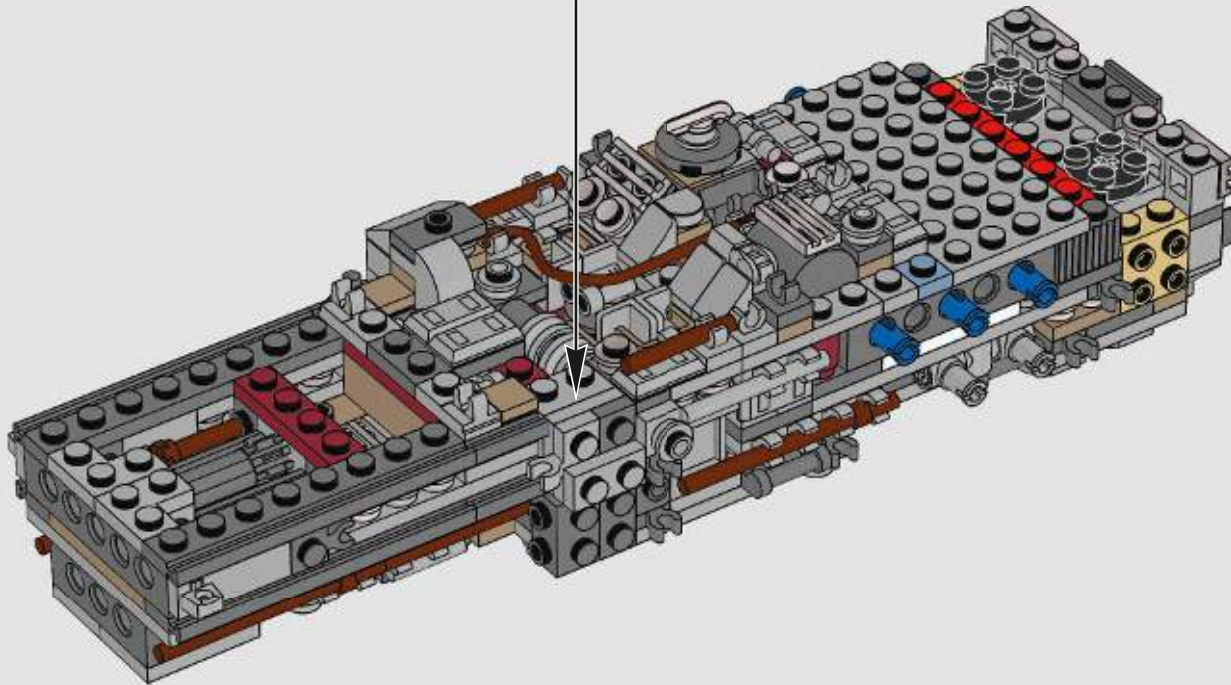
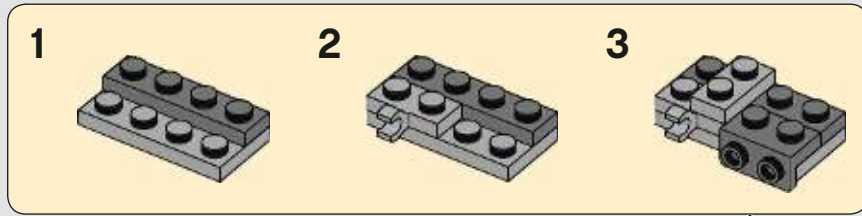



80

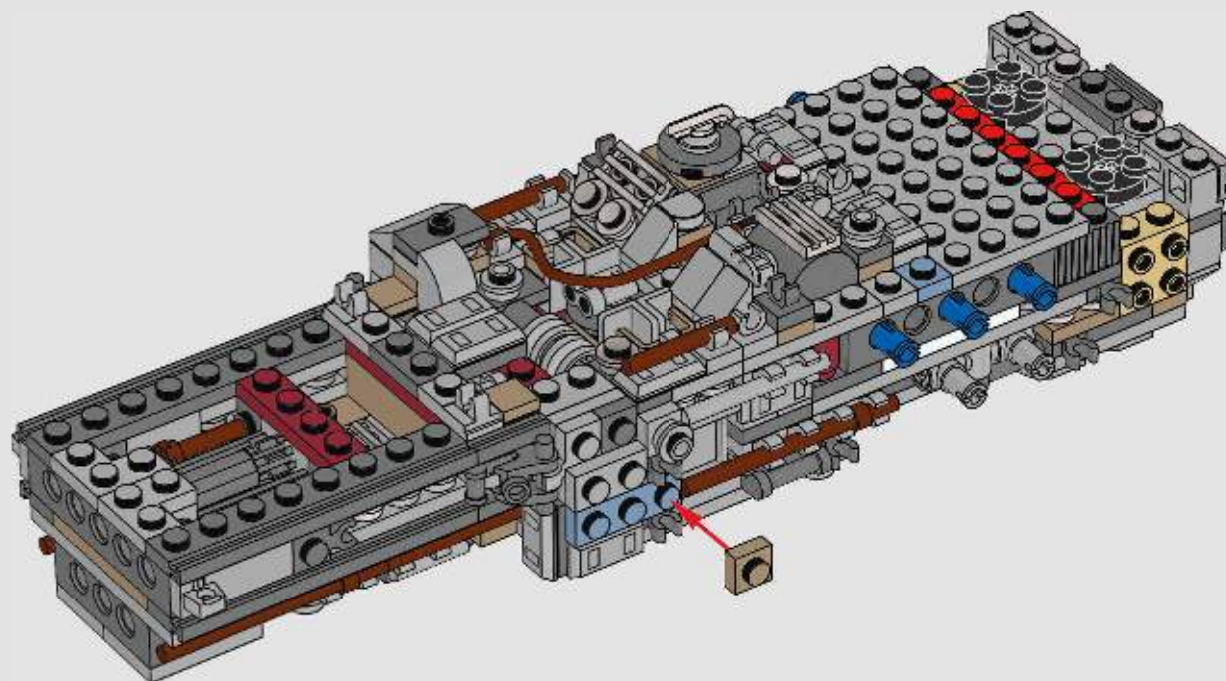



81

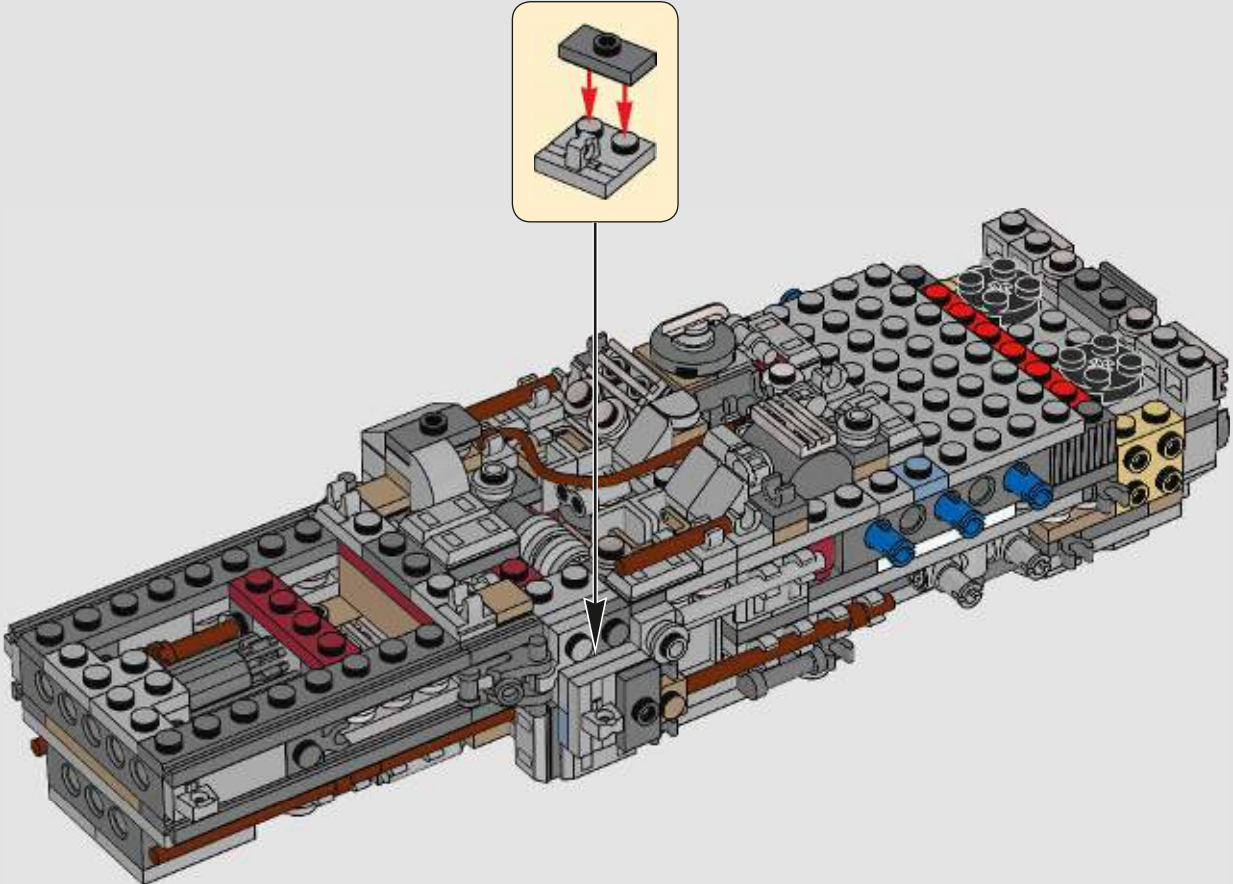

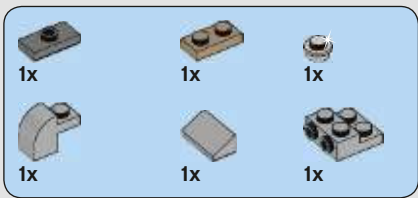

82

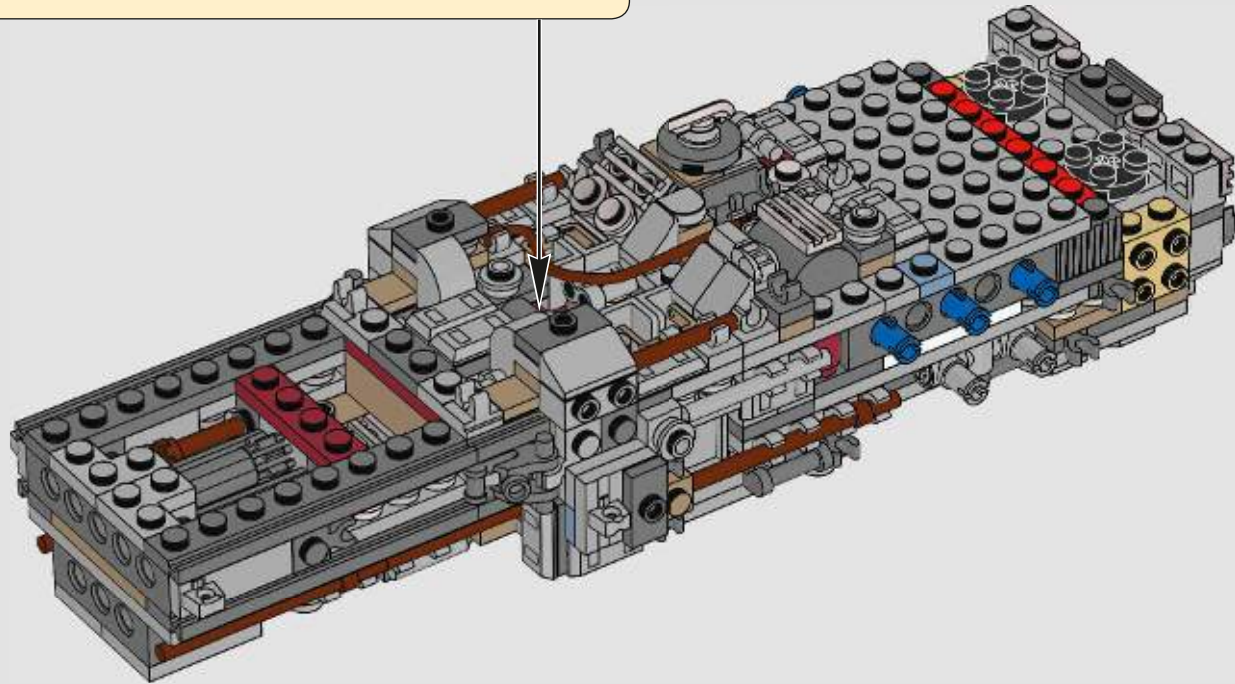
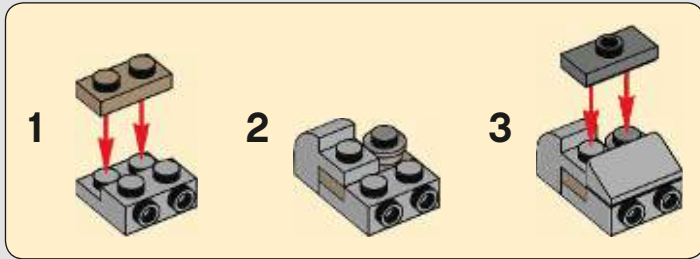

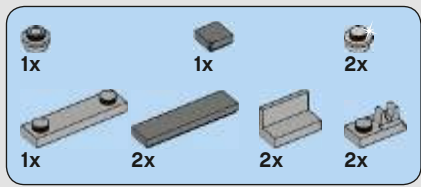

83

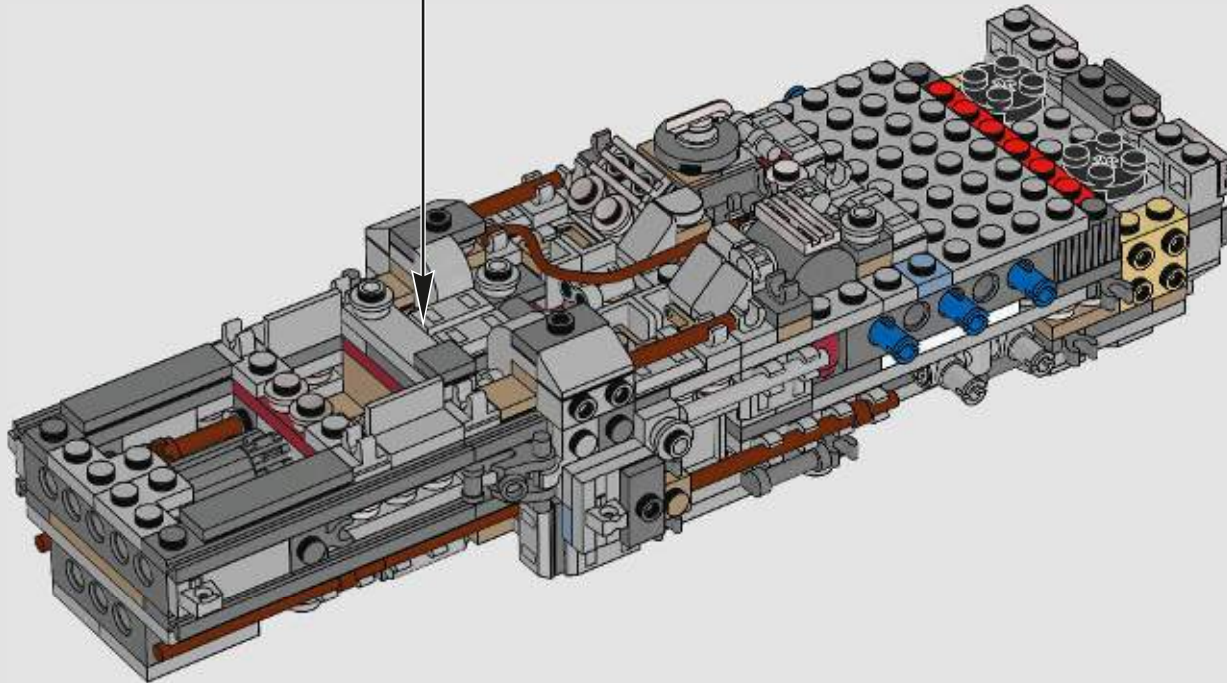
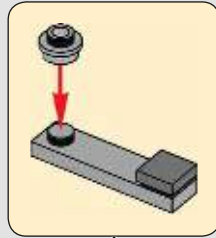

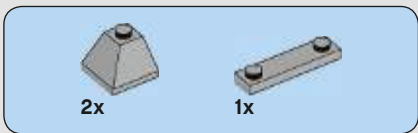

84

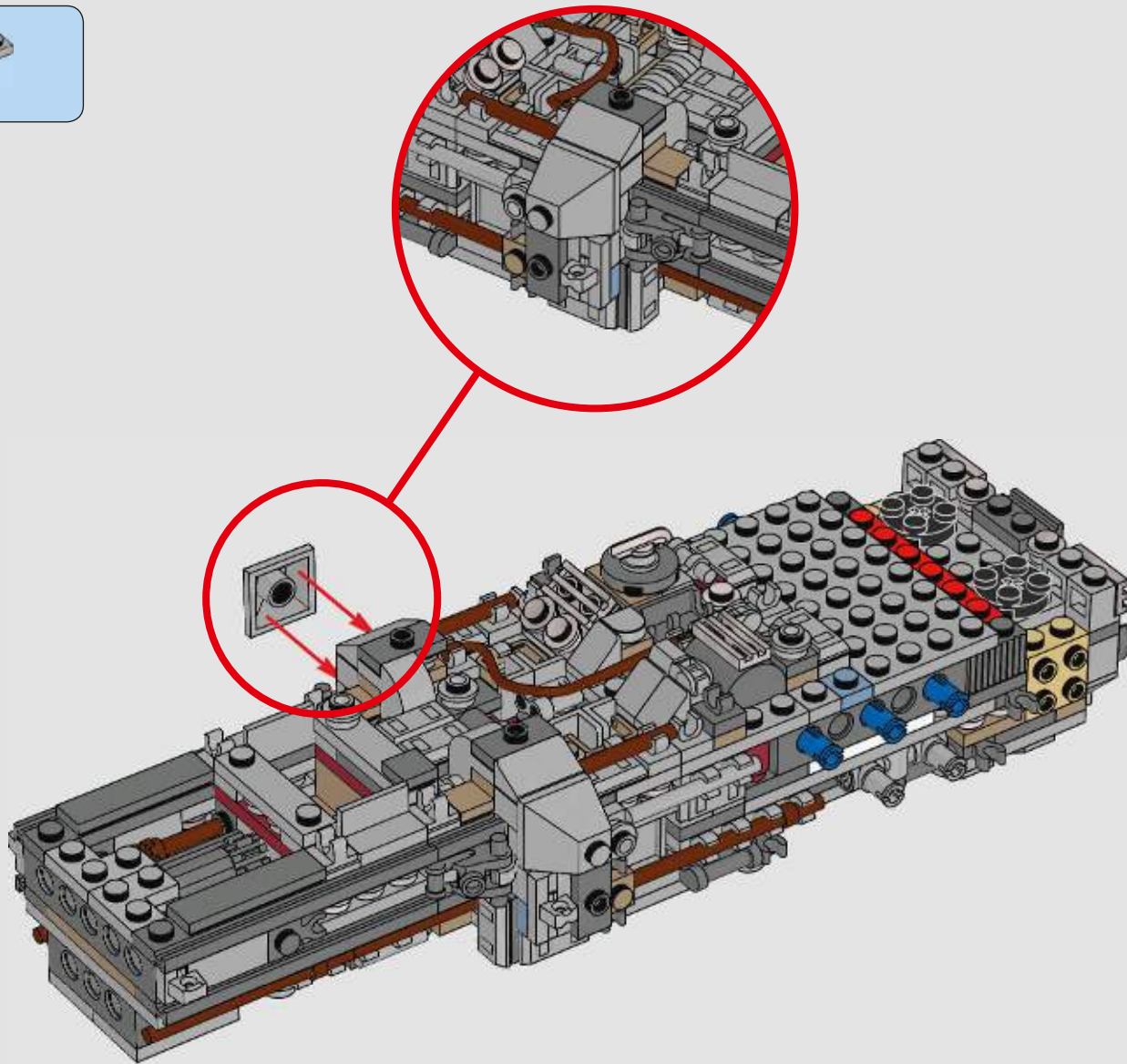



85

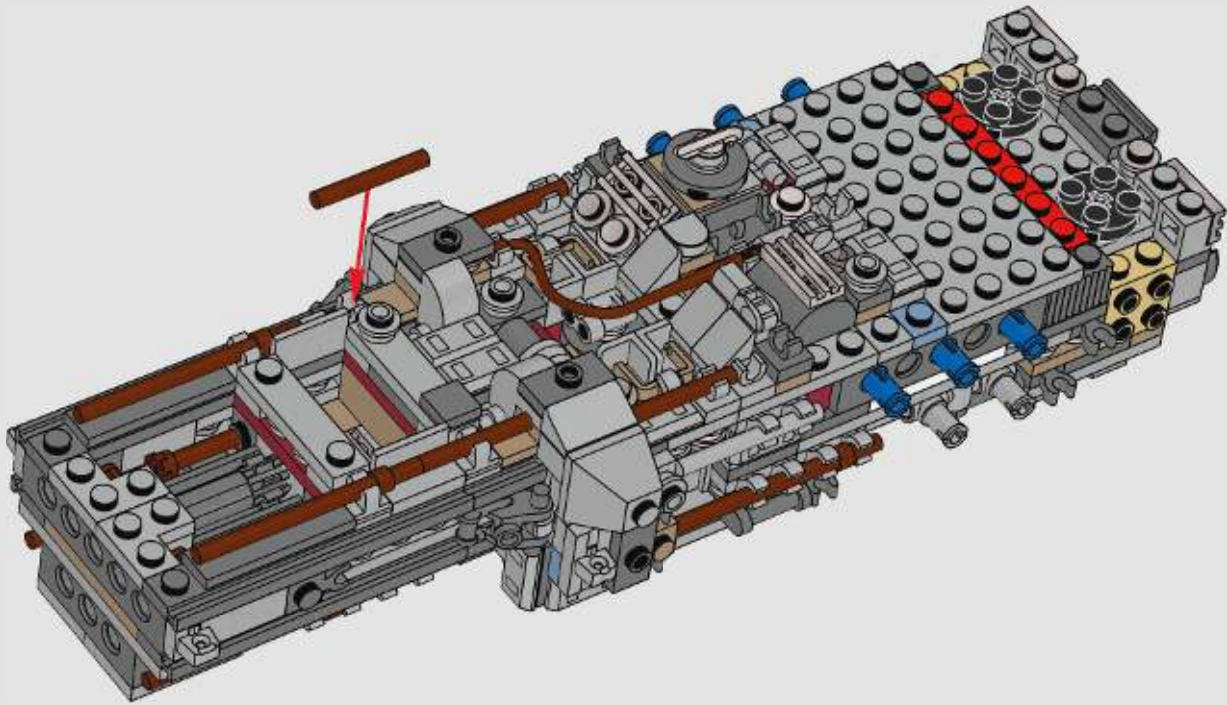

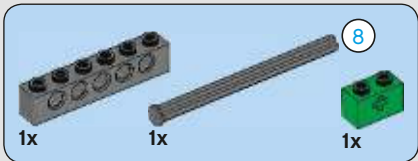
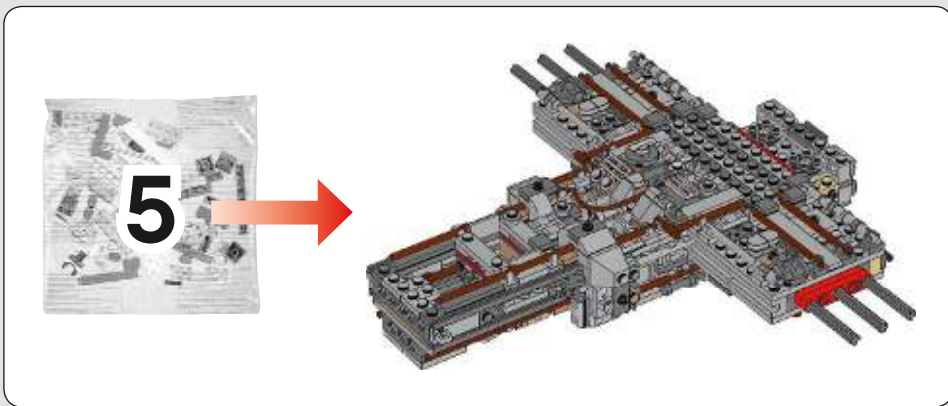

86

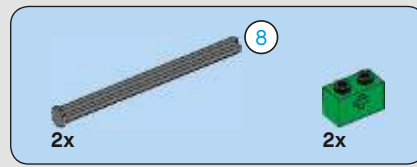
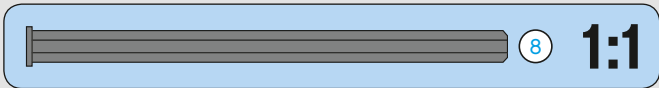
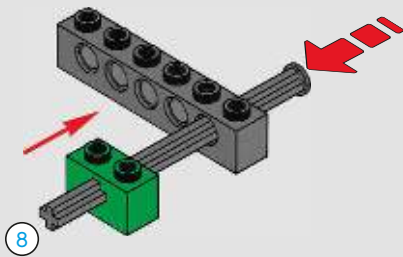

87

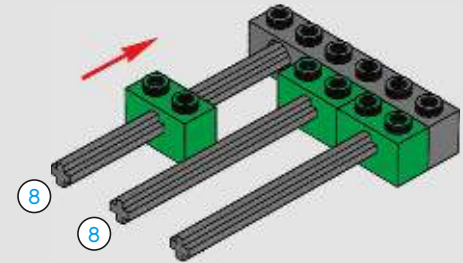

88

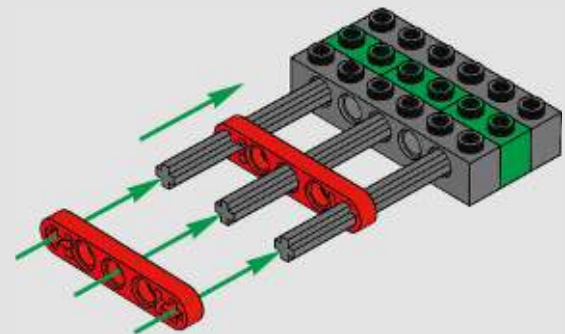

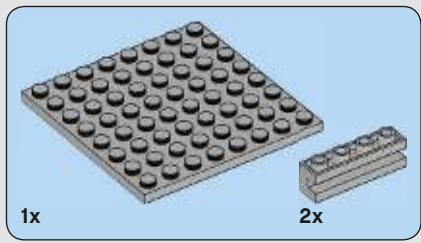

89

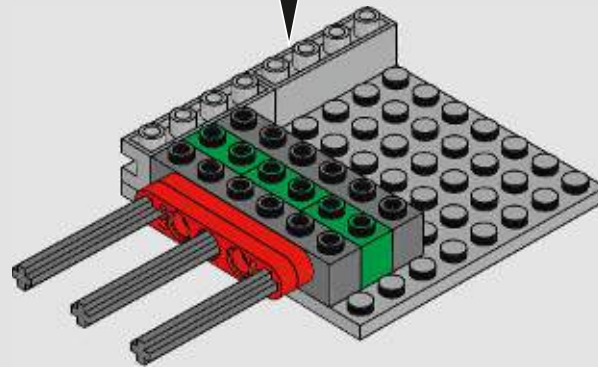
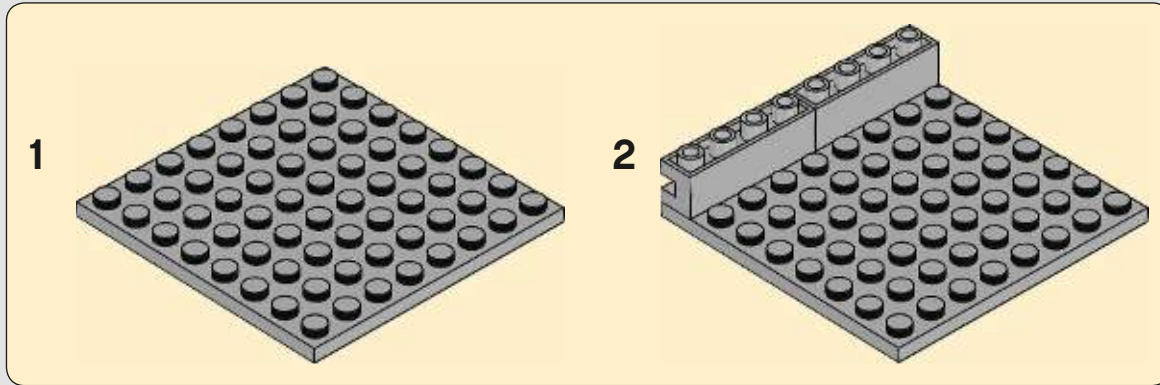

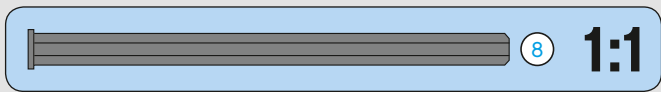
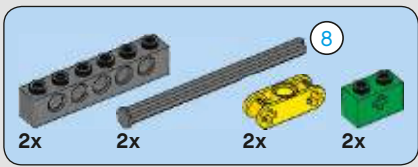

90

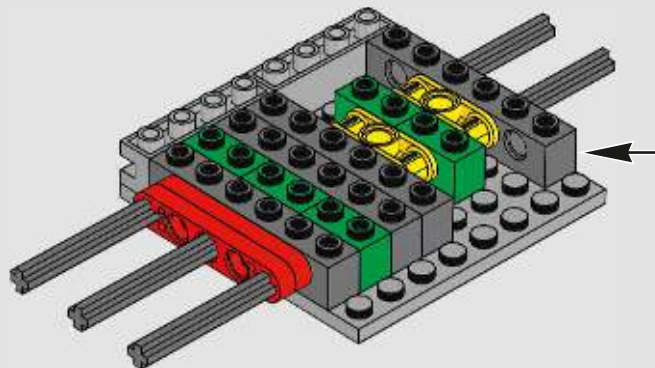
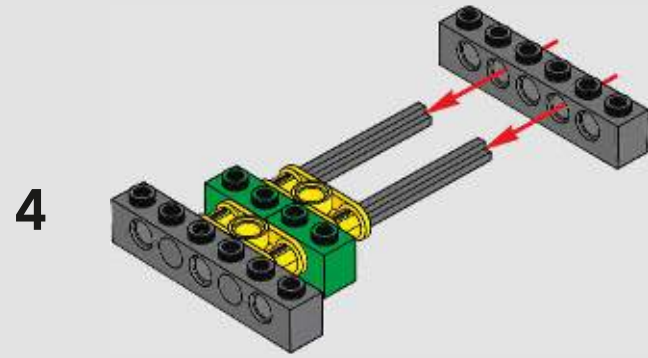
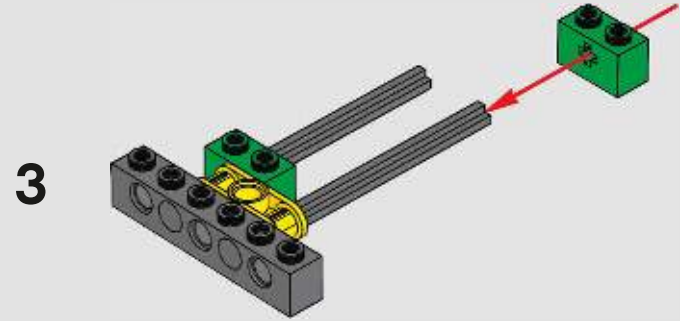
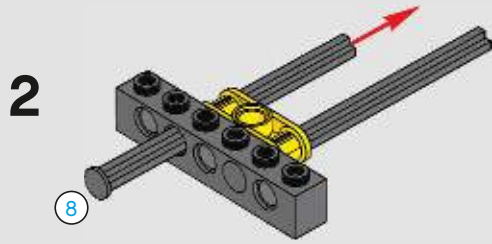
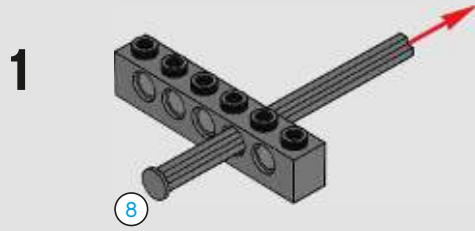

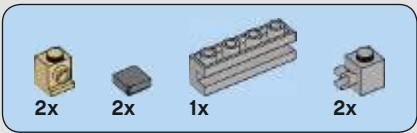

91

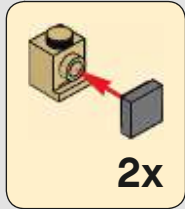

2x

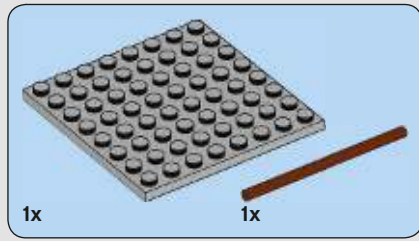
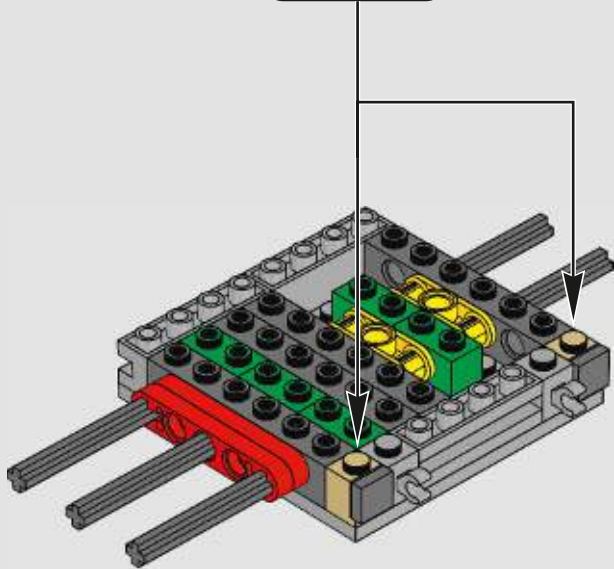

92

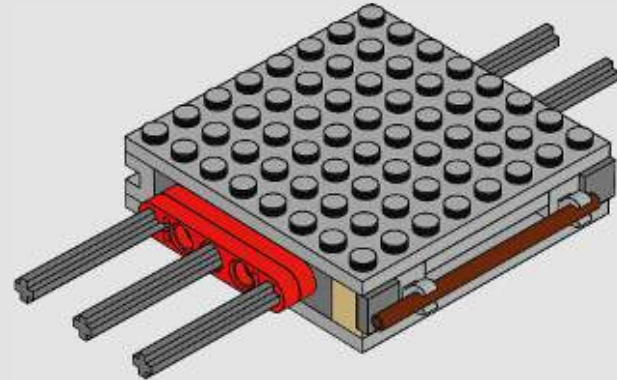

93

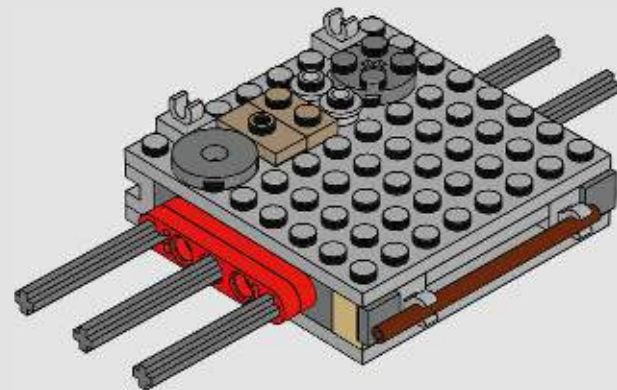

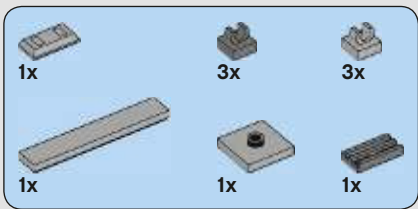

94

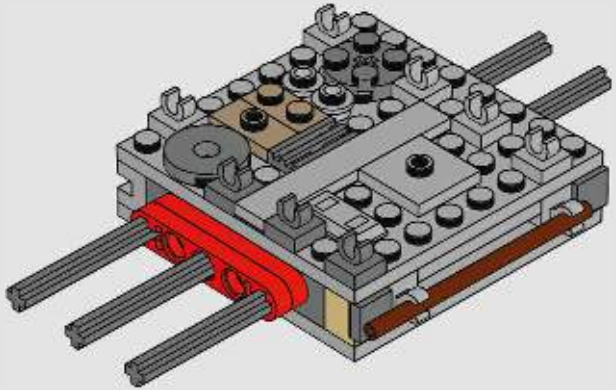

95

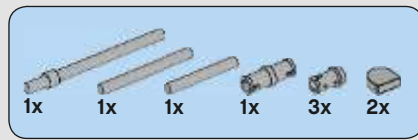
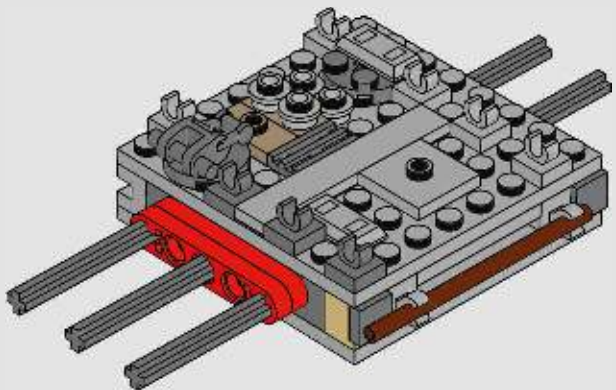

96

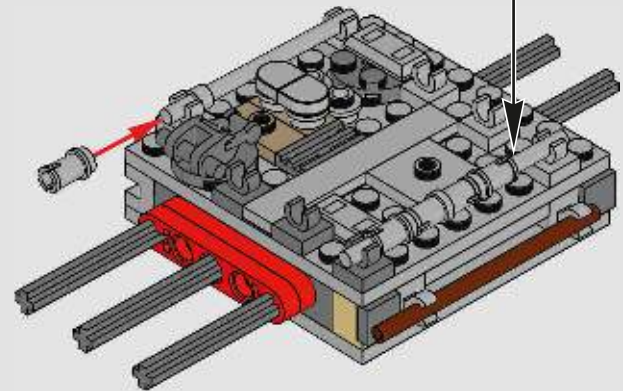
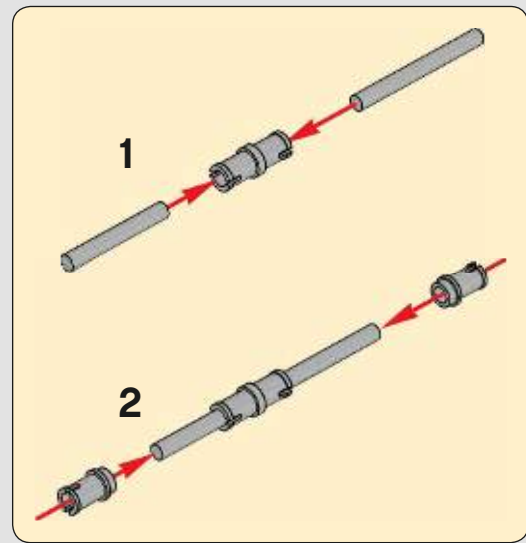



97

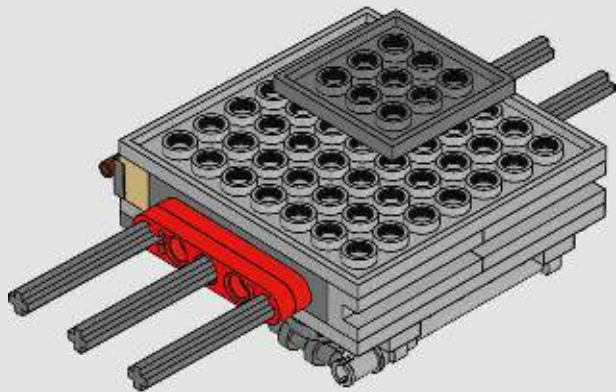

98

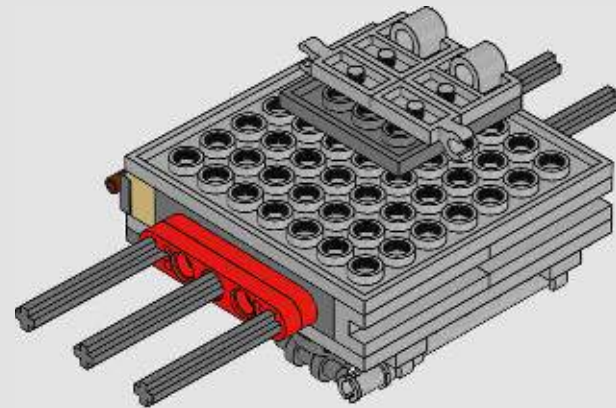

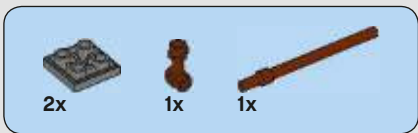

99

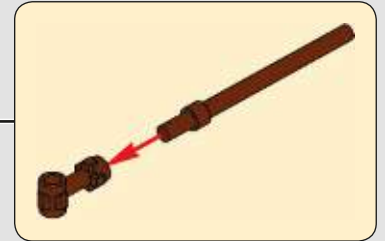
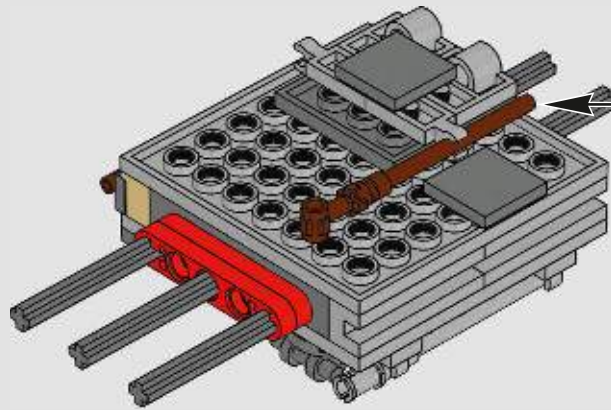

100

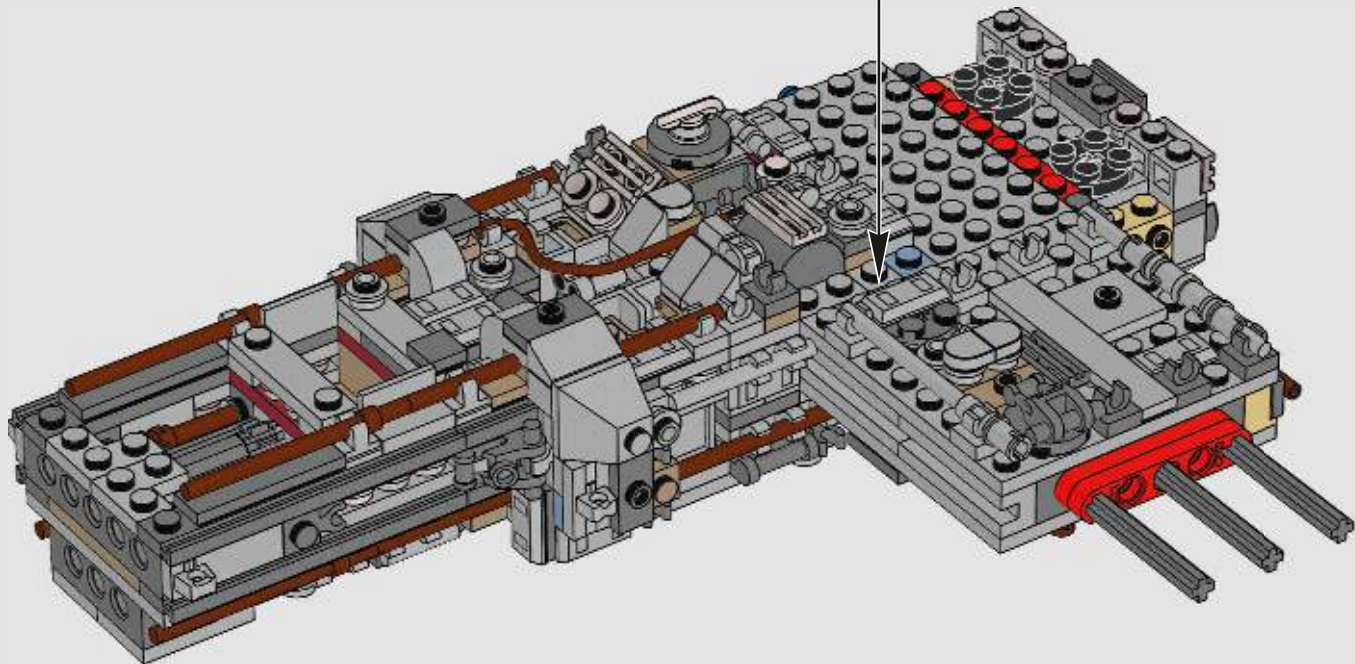

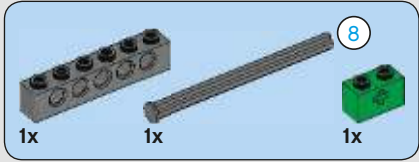
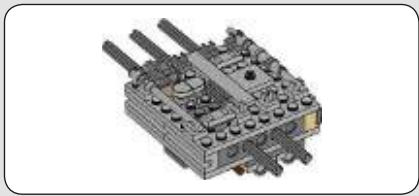

101

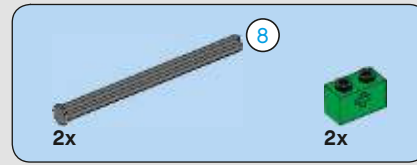
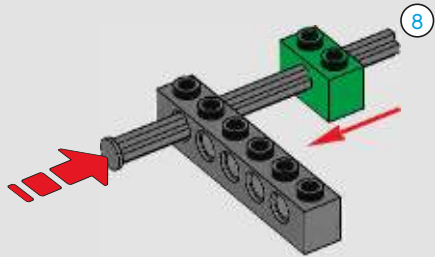

102

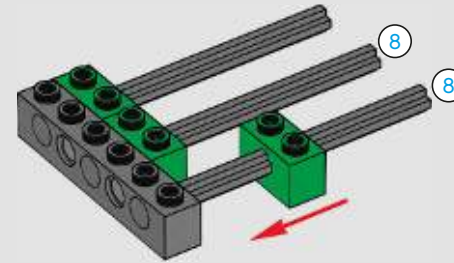

103

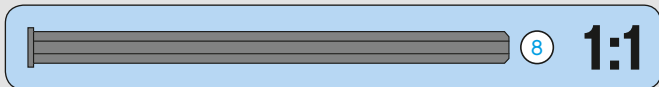
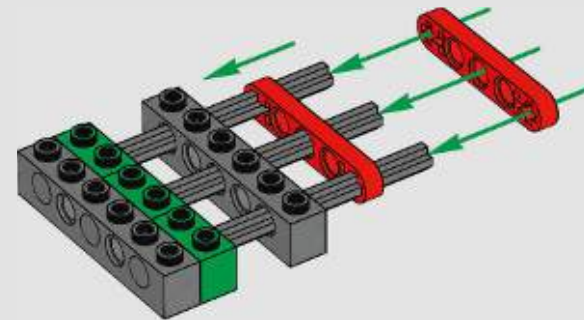

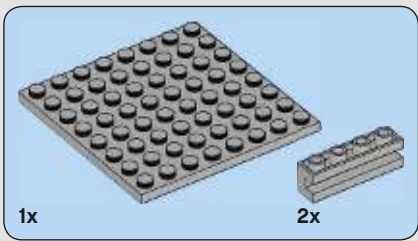

104

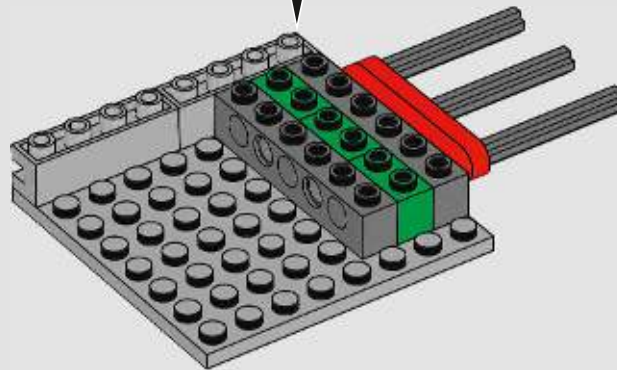
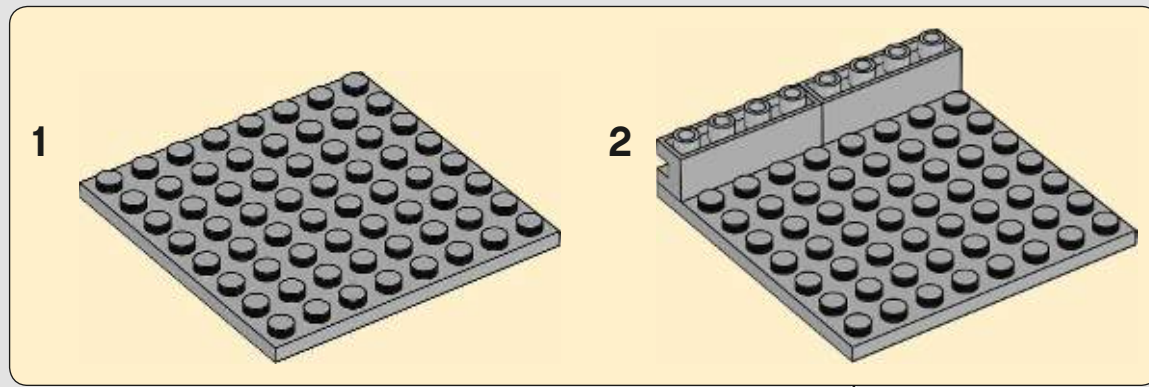

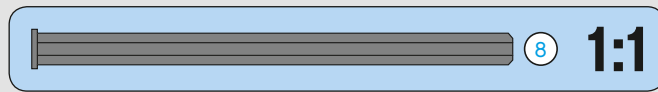
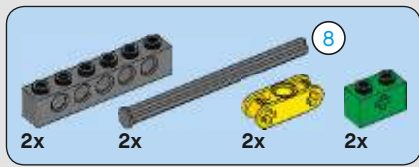

105

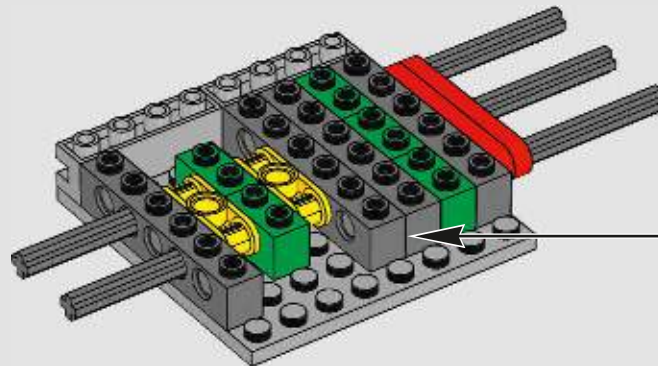
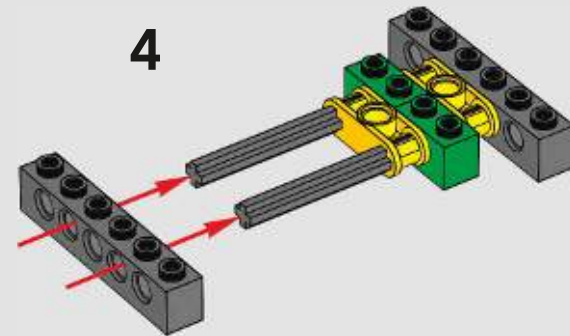
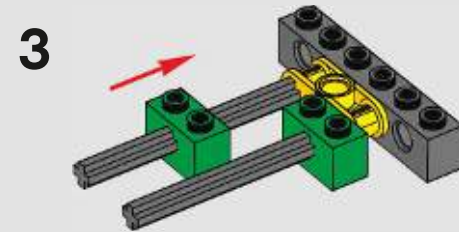
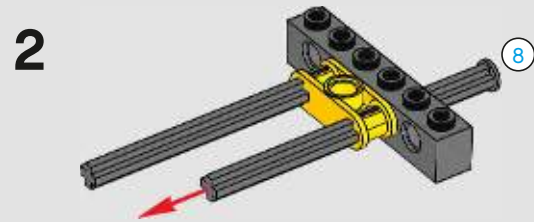
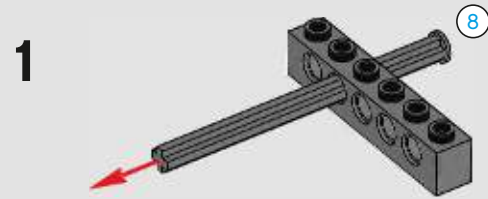

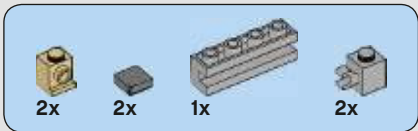

106

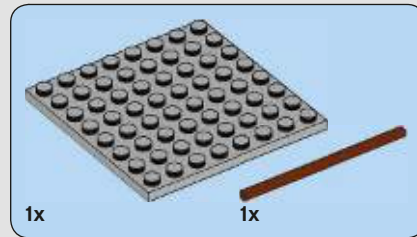
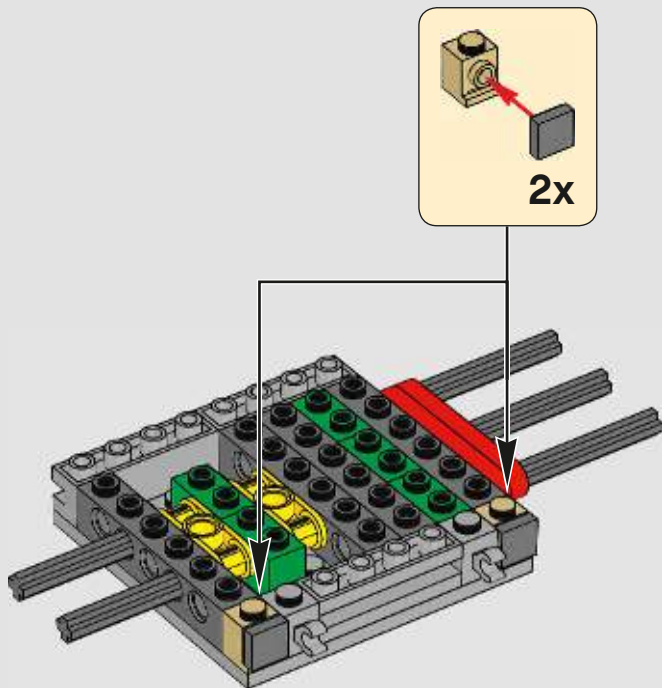

107

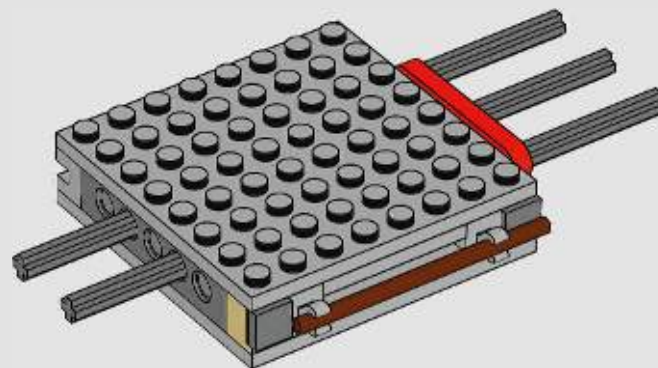

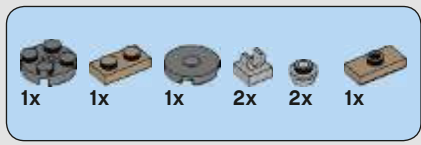

108

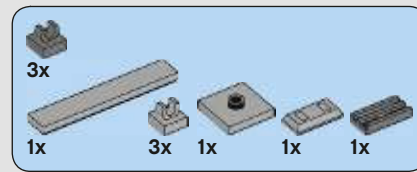
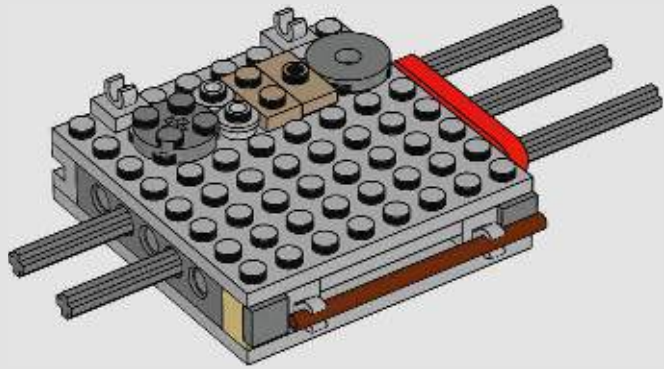

109

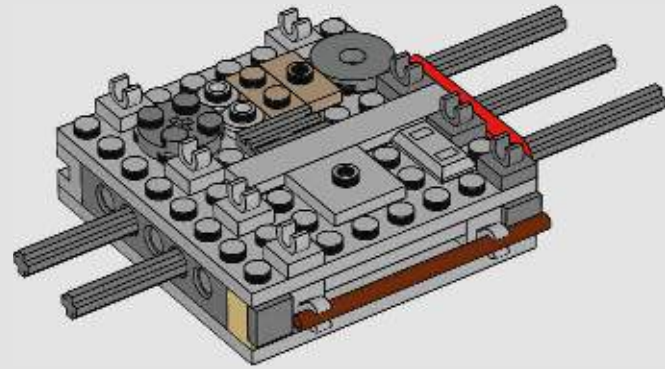



110

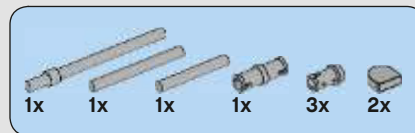
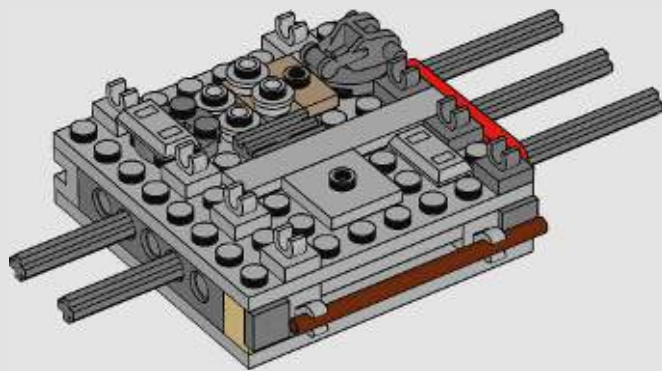

111

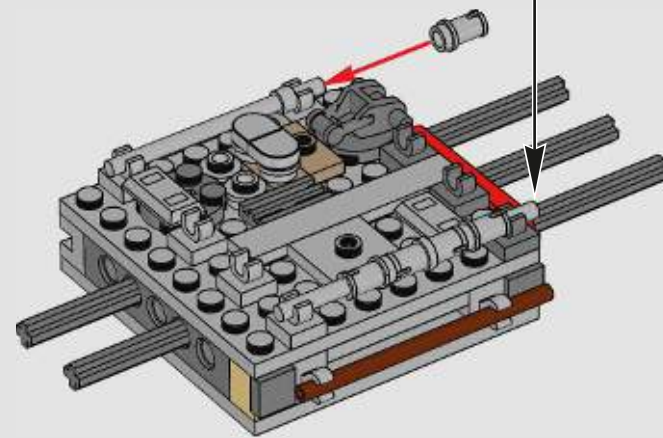
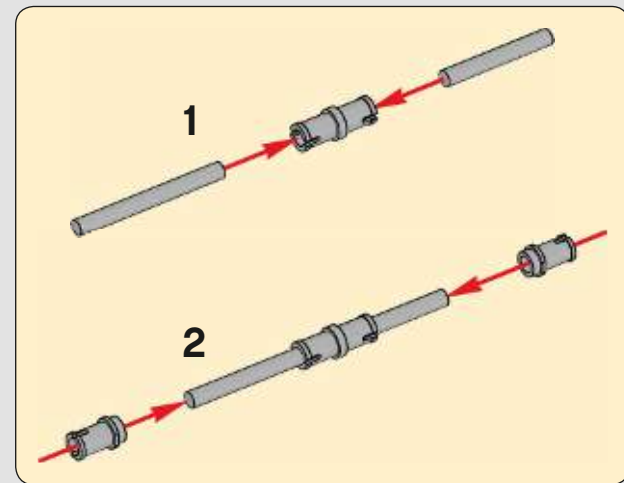



1x

112

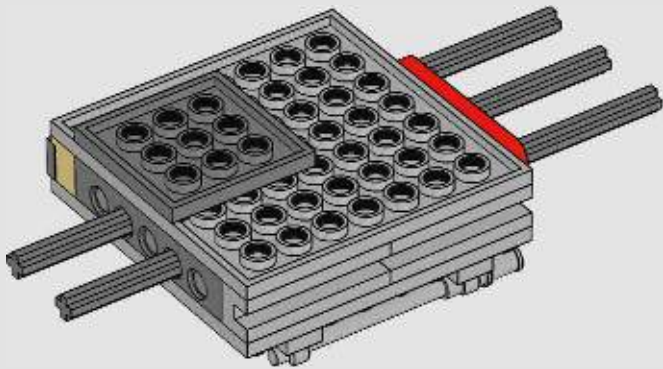

113

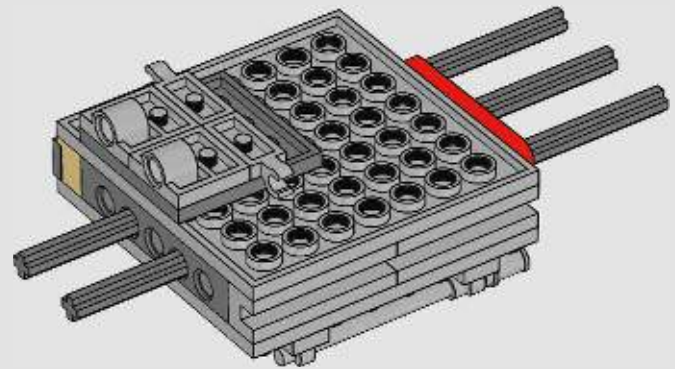

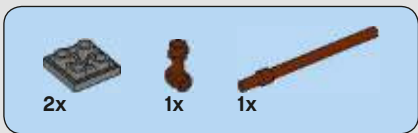

114

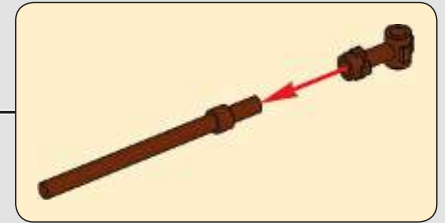
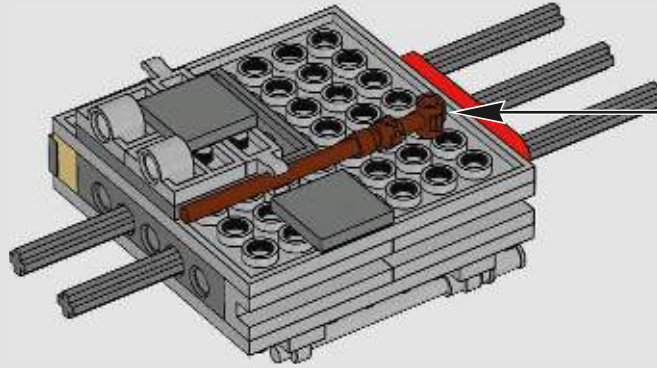

115

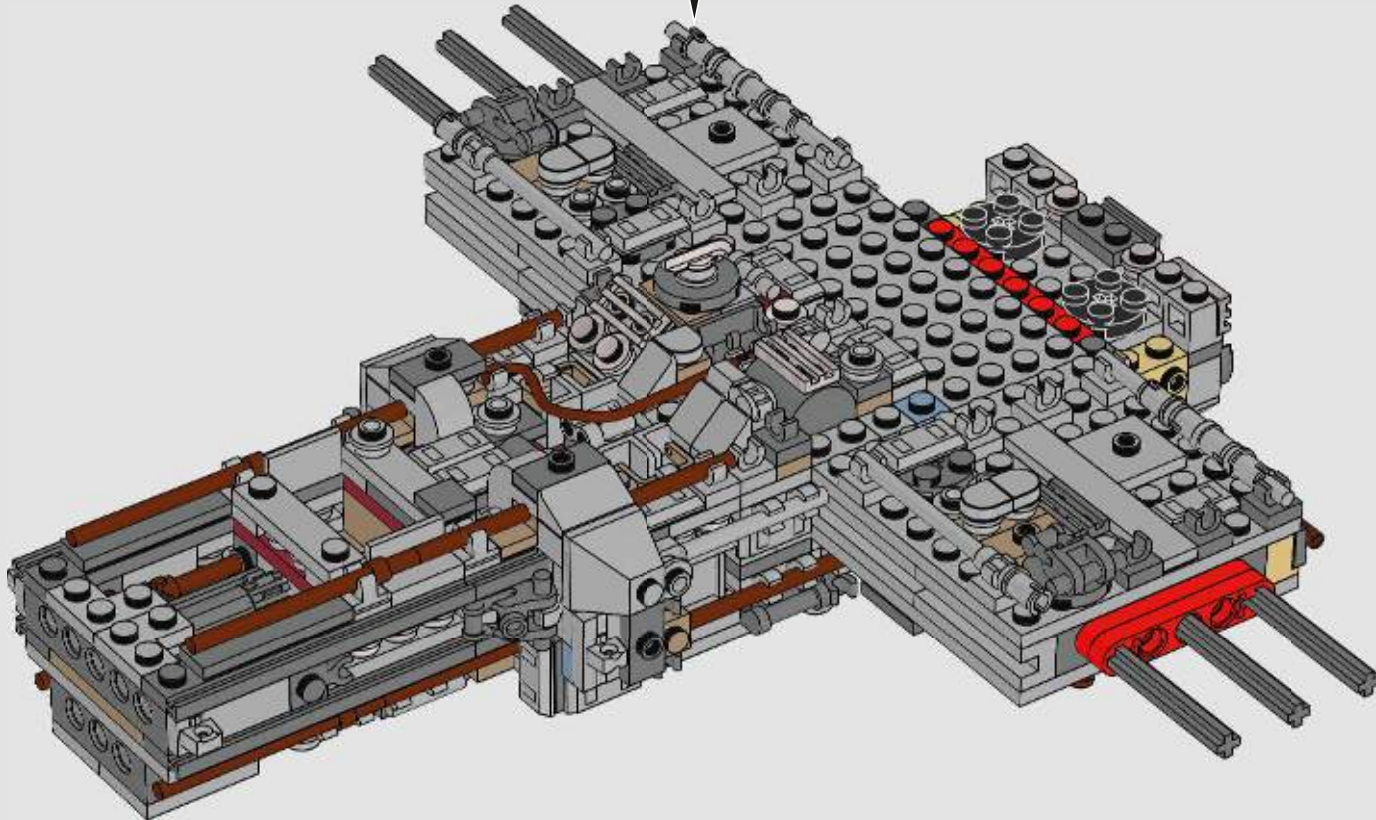

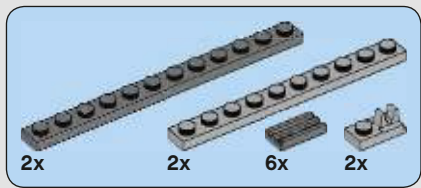

116

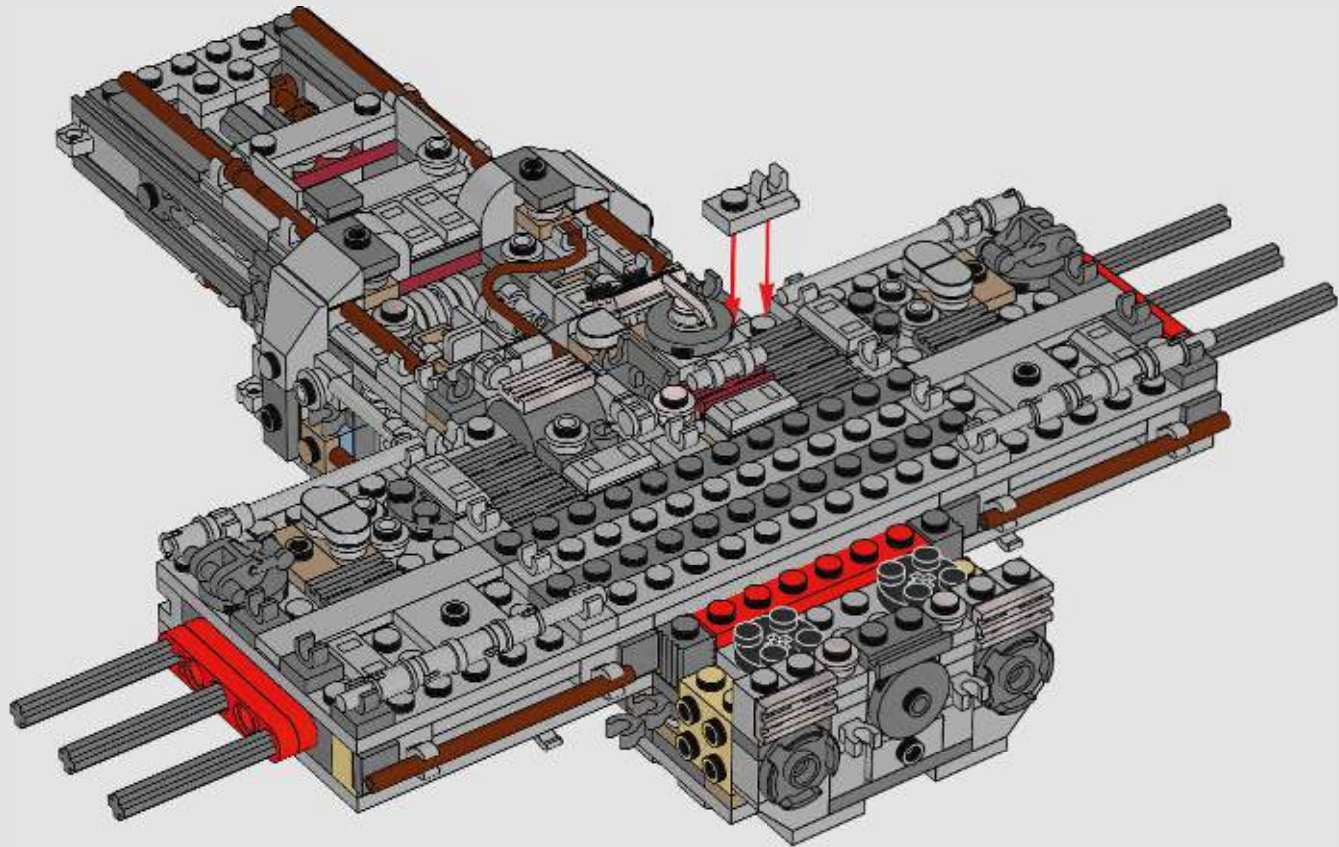

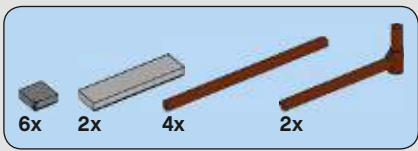

117

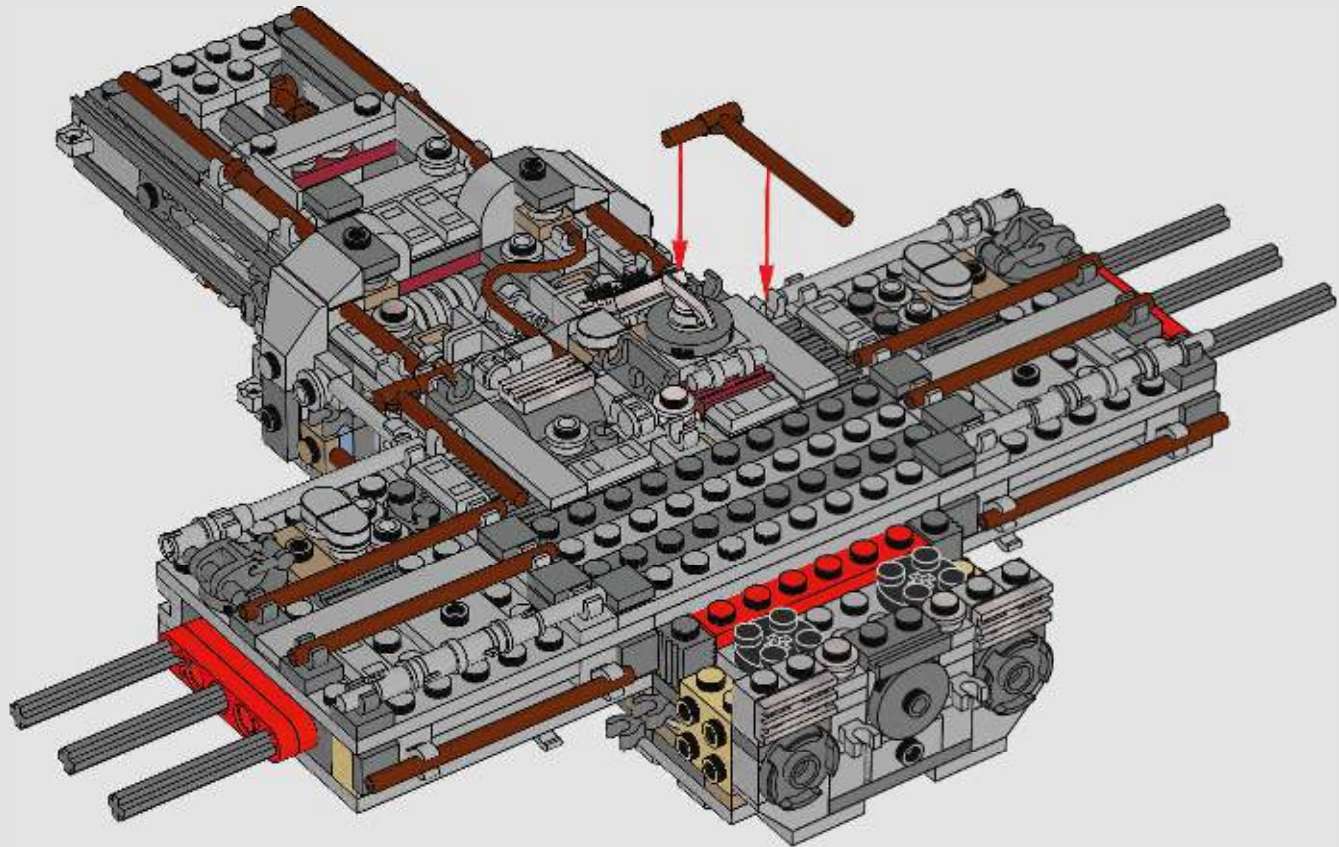



118

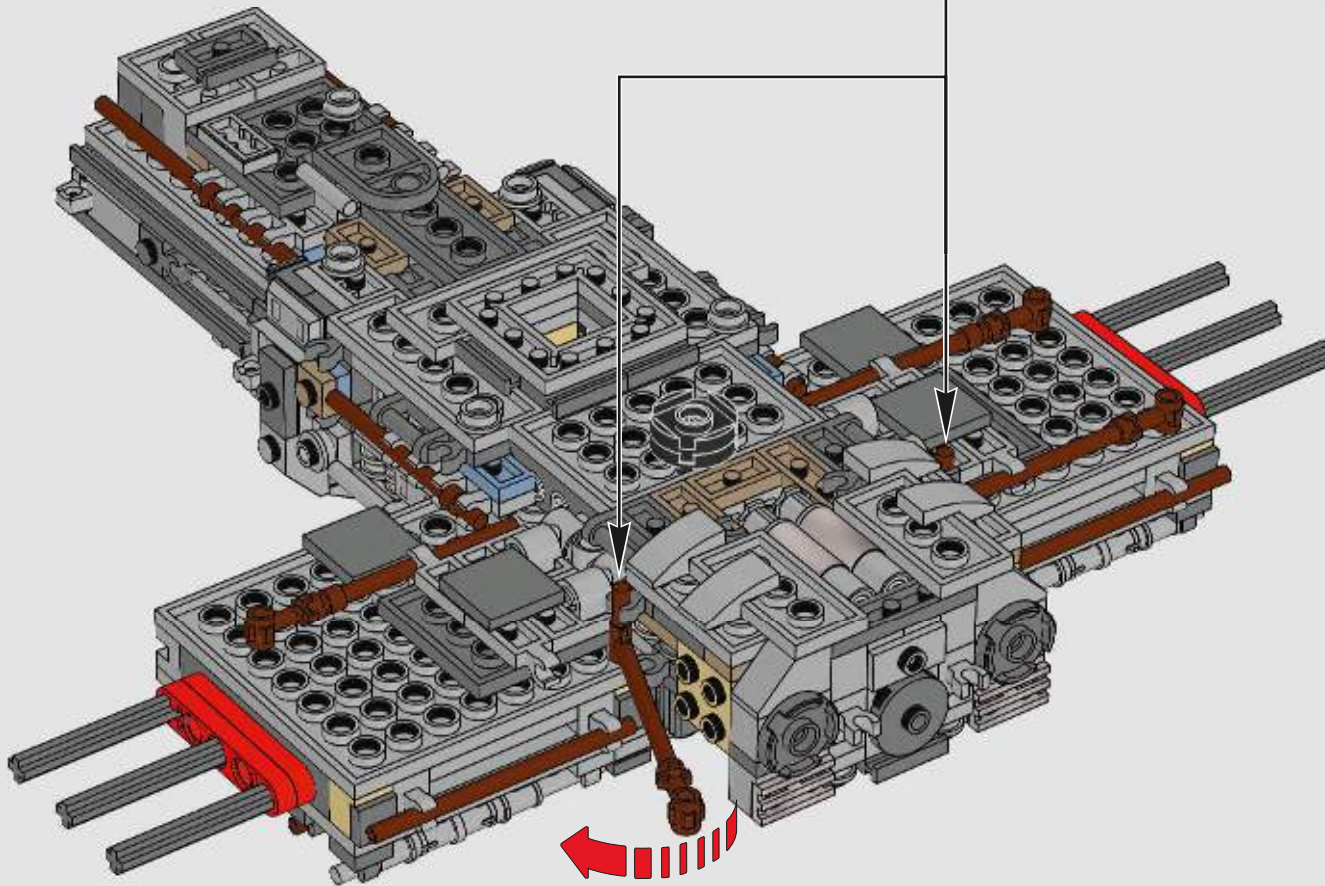
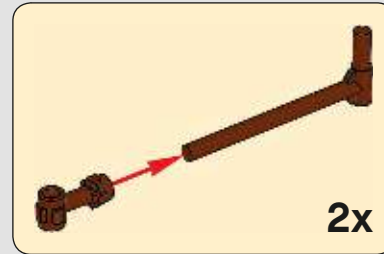

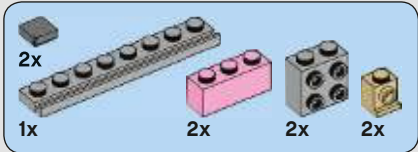
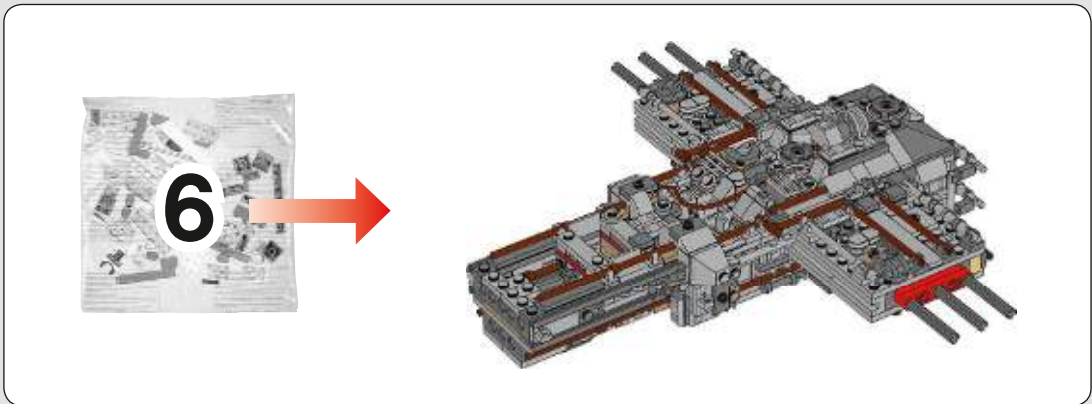

119

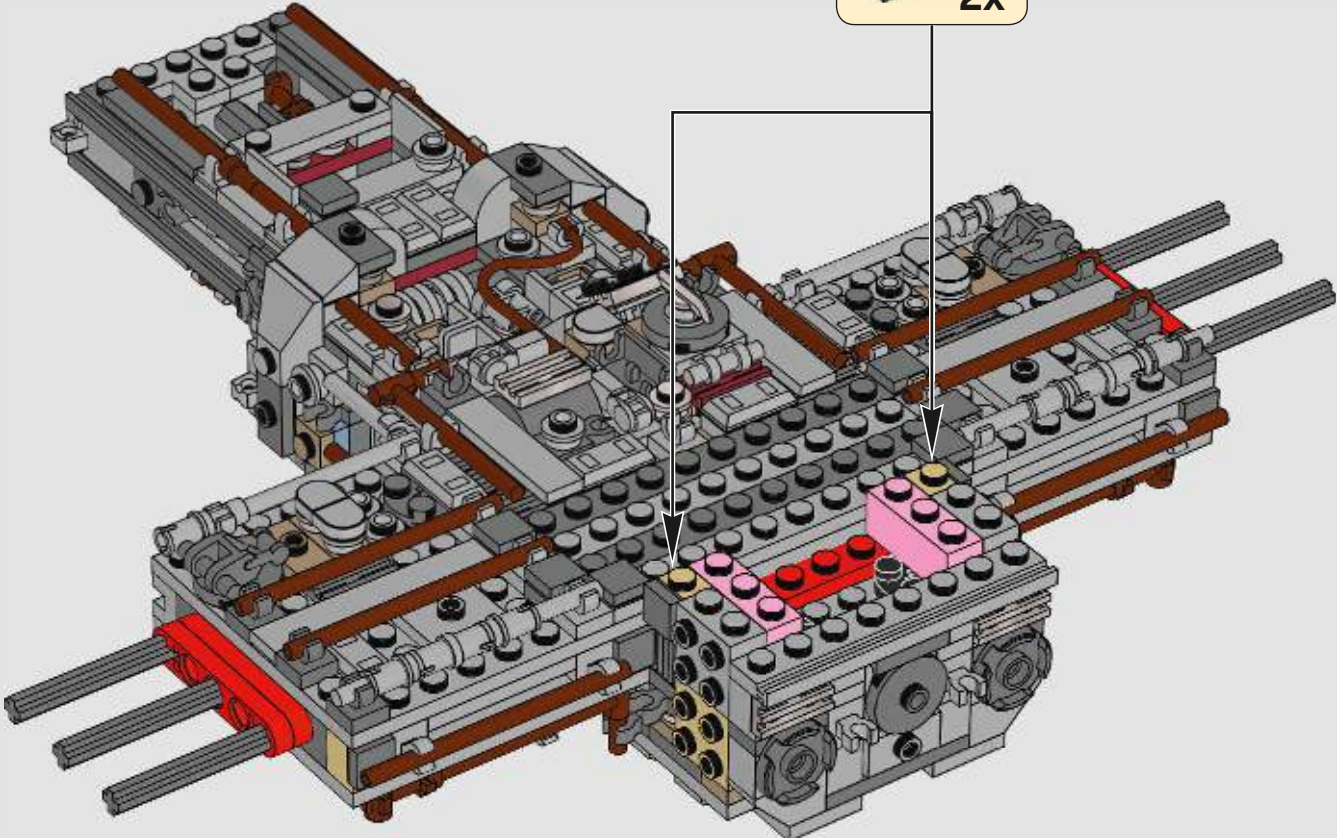
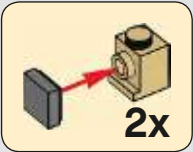



1x



2x

120

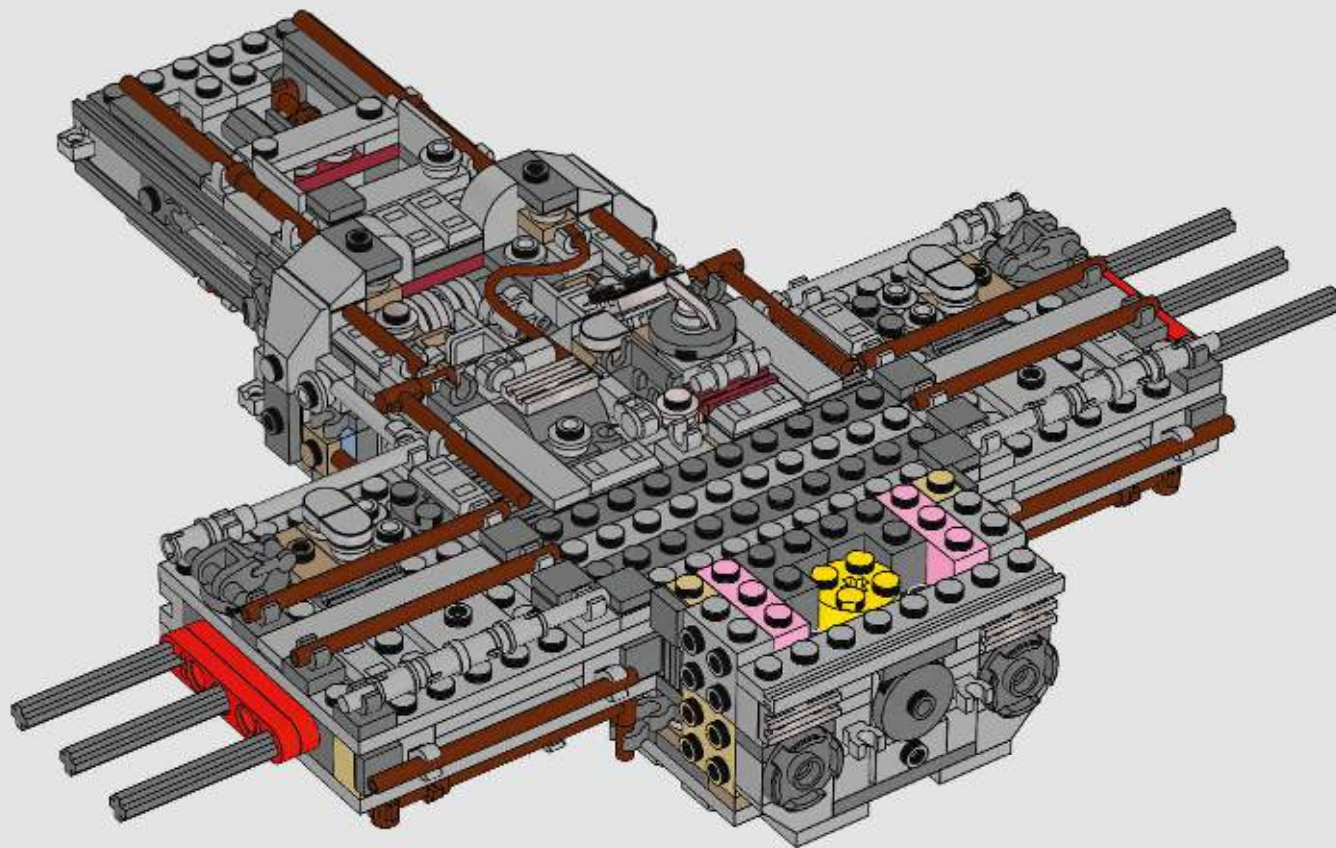

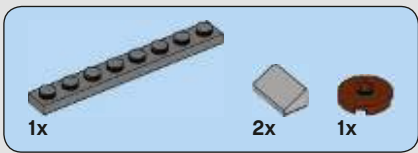

121

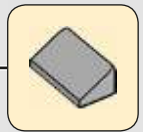
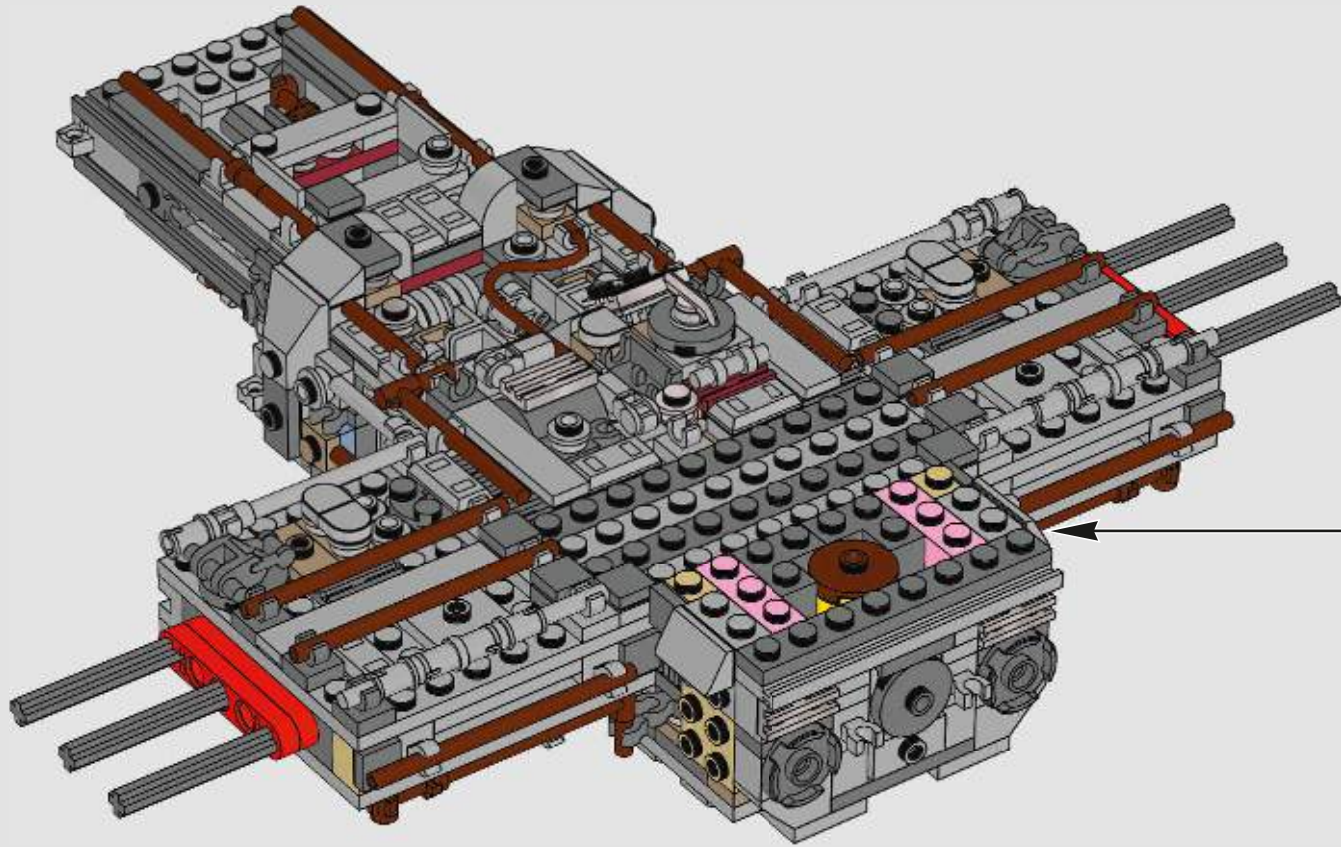

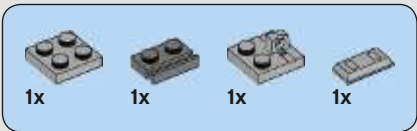

122

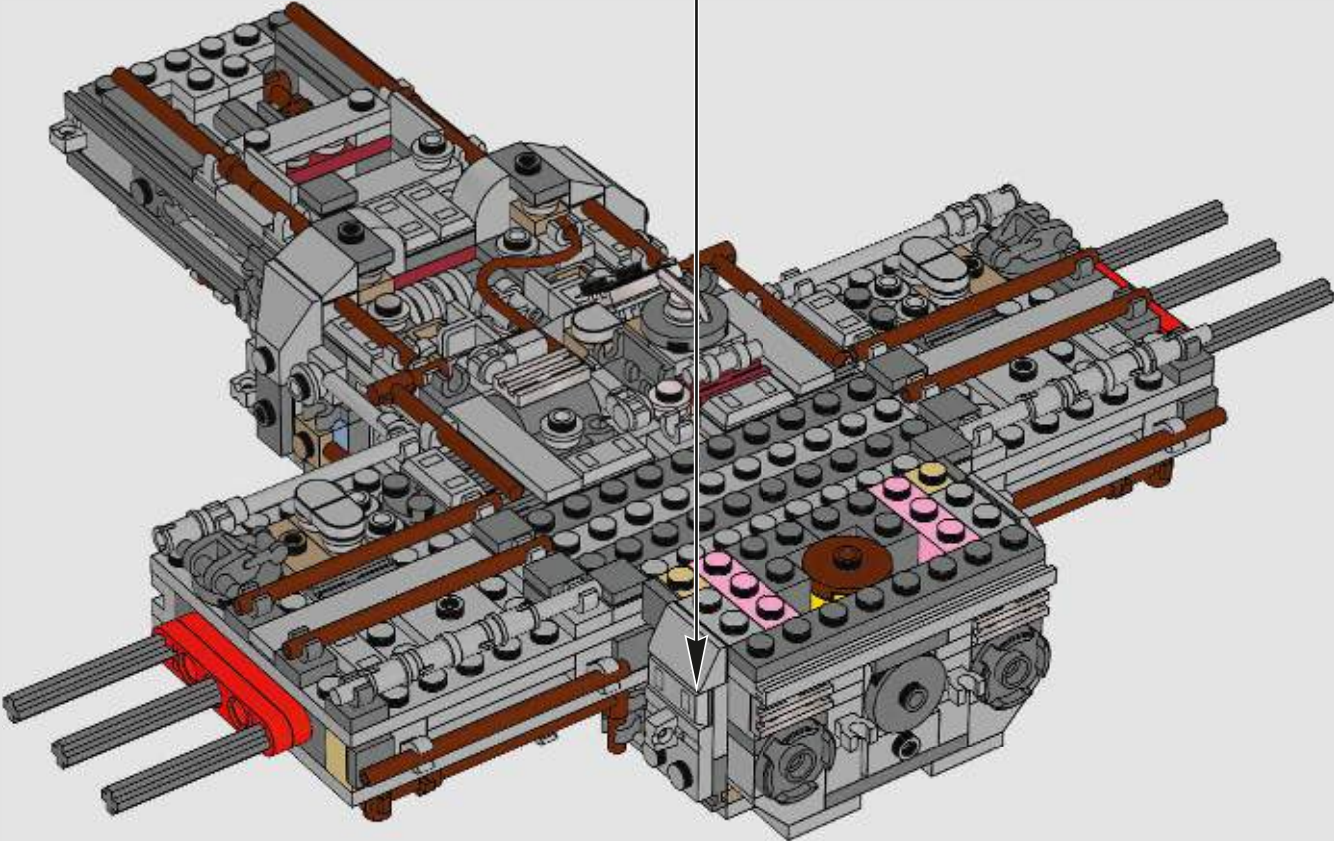
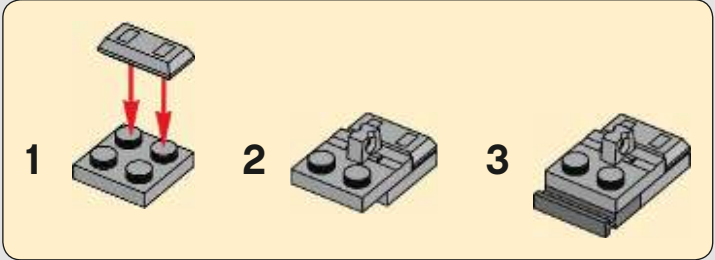



123

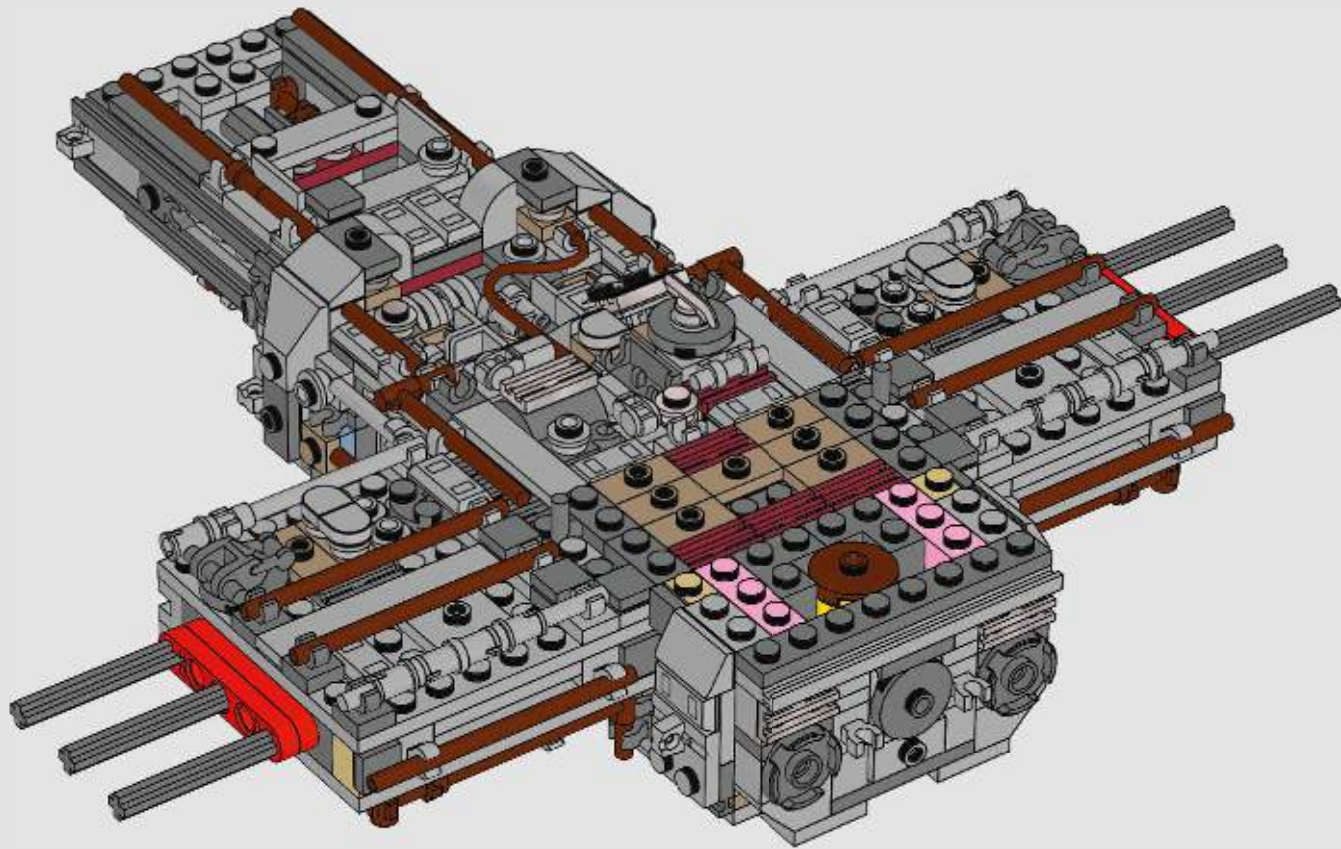



124

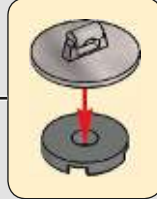
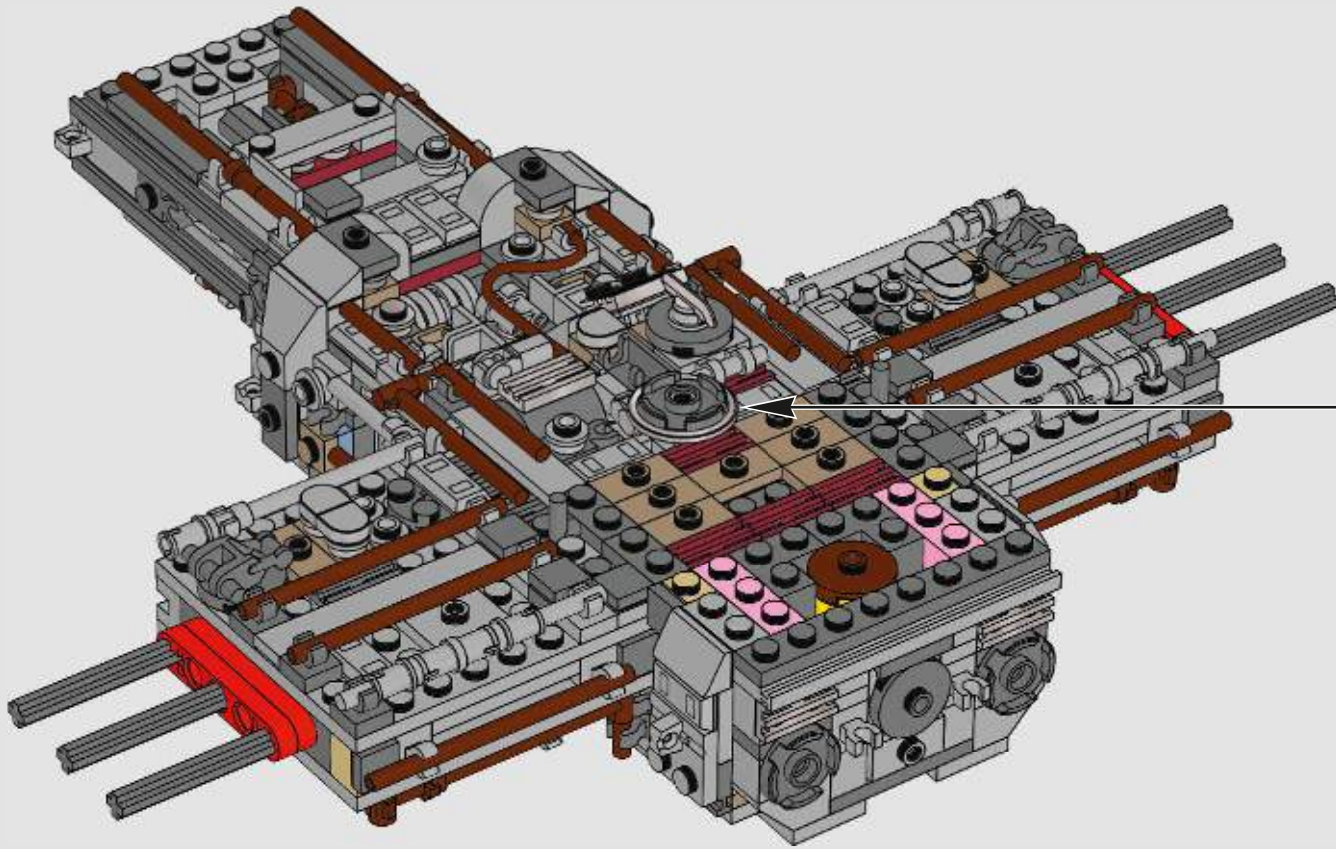

4x 2x 2x

125

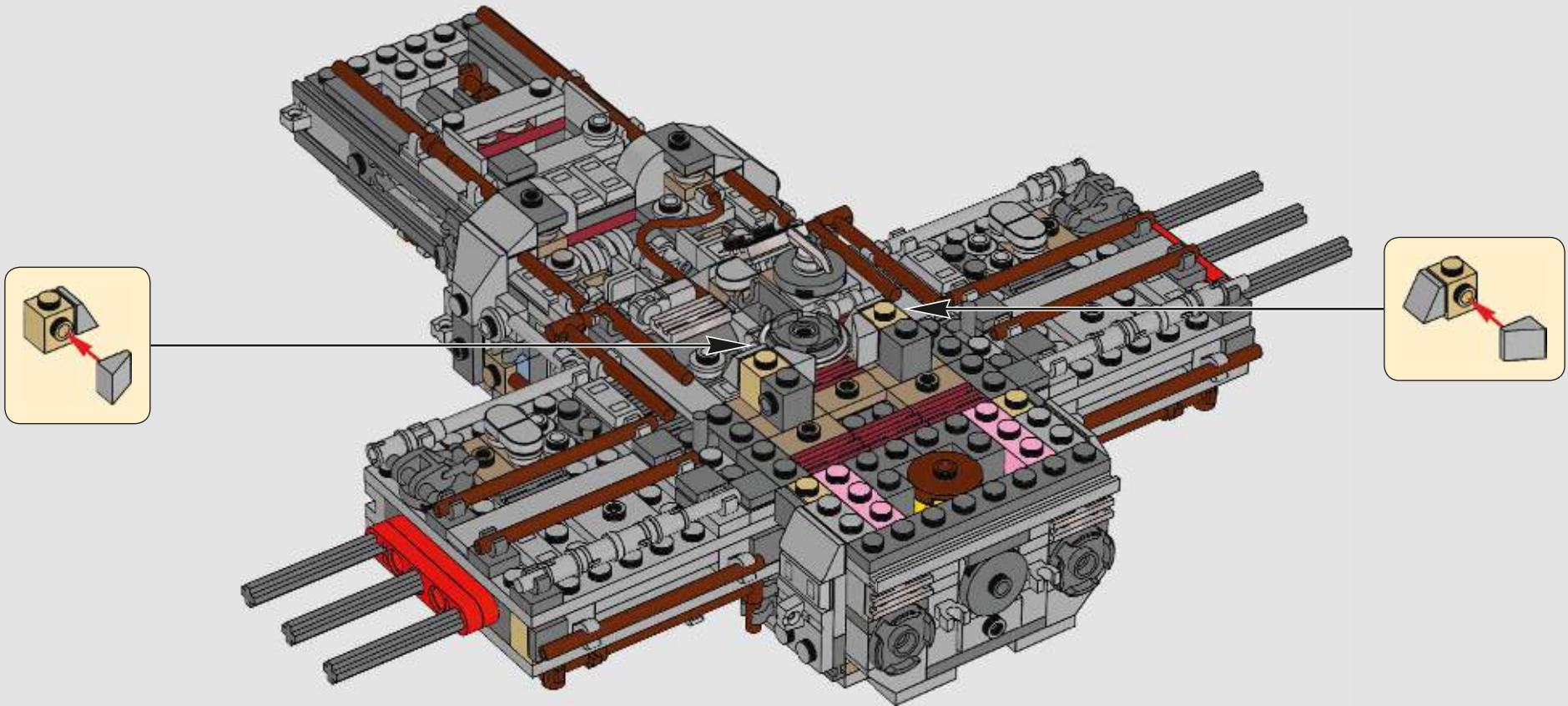



126

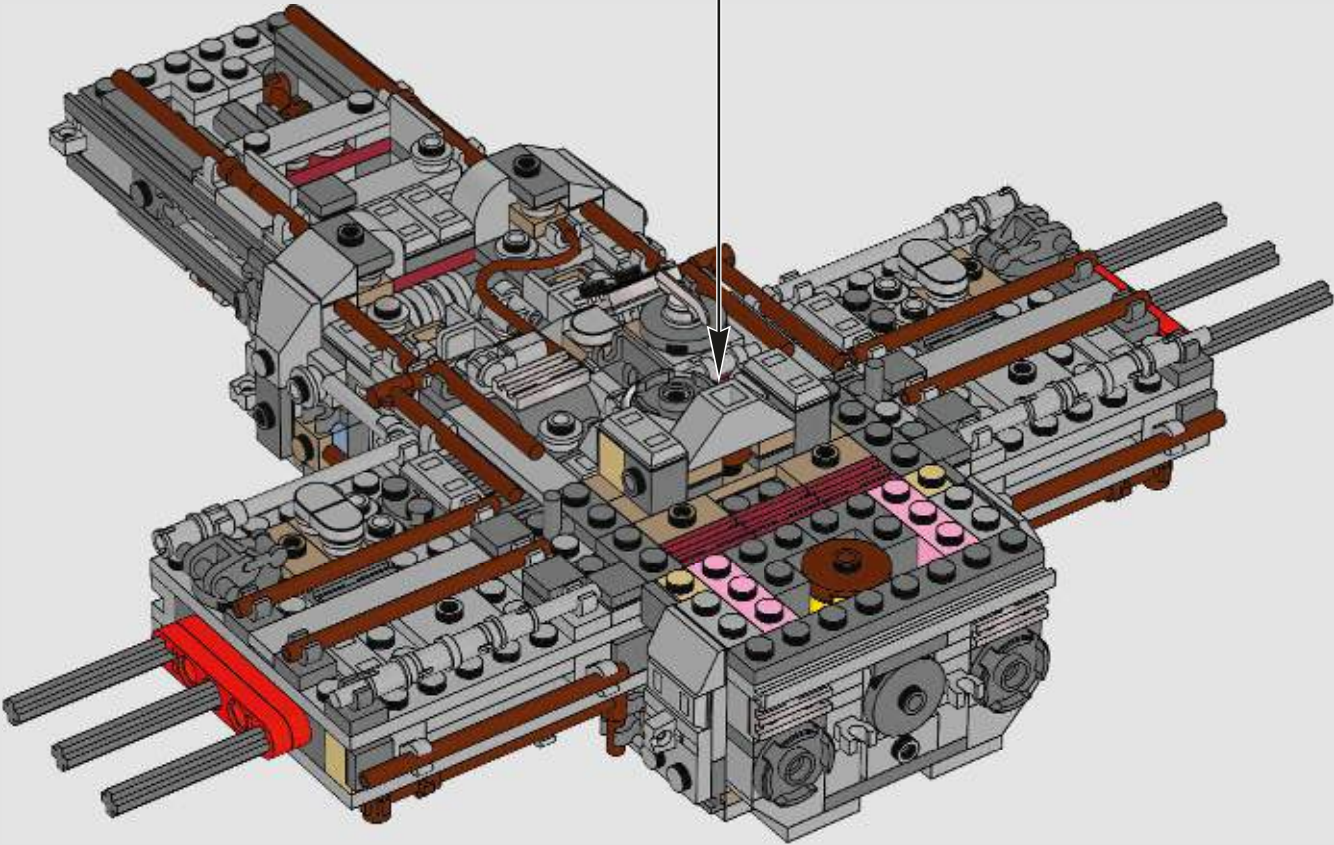
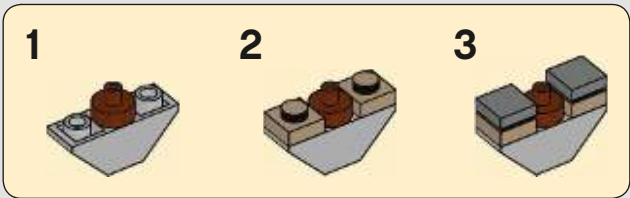

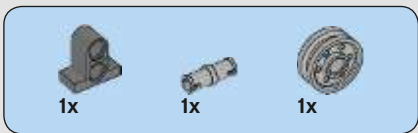

127

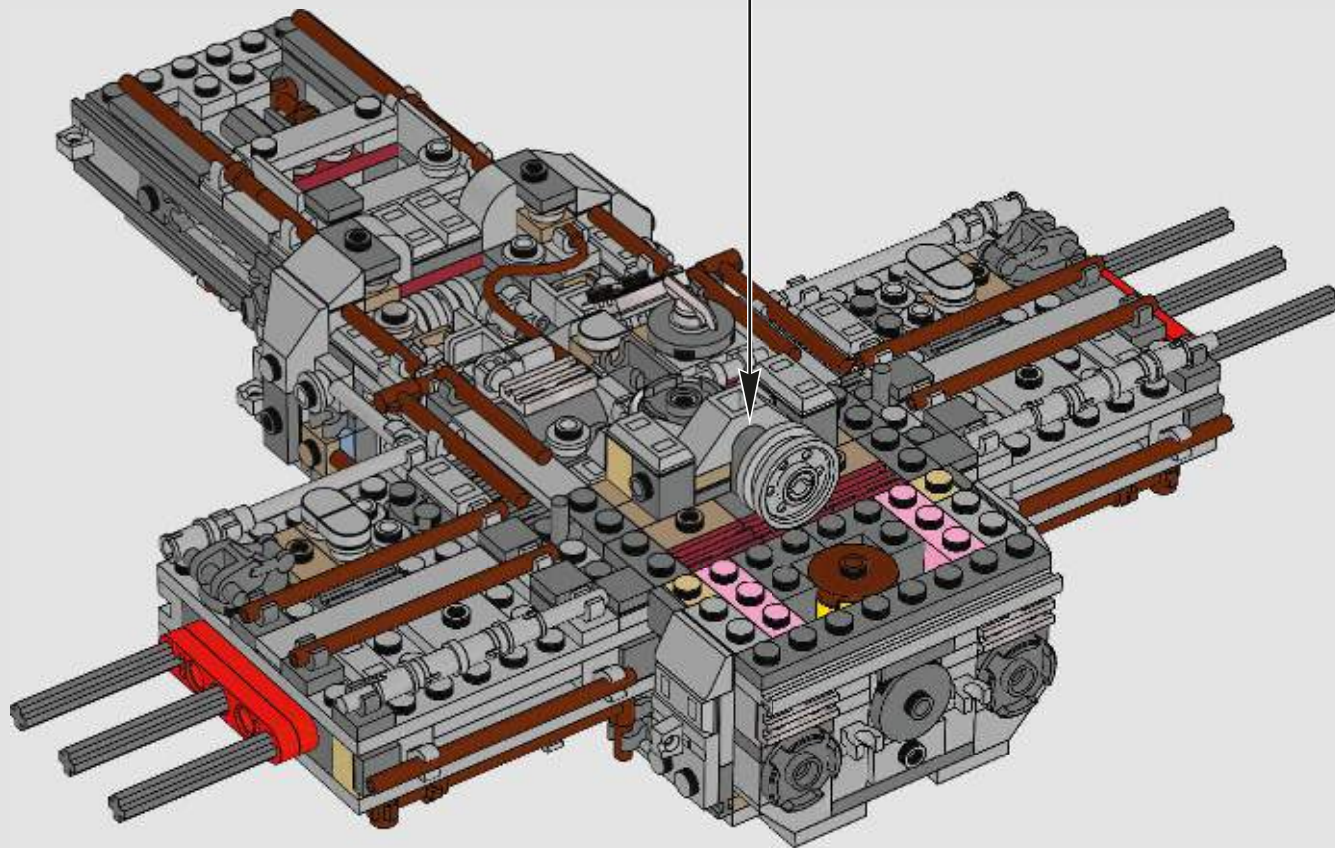
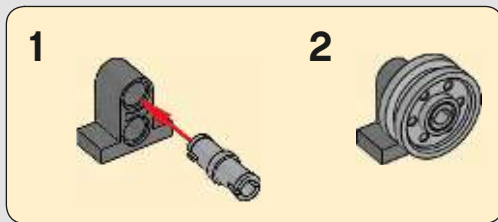



128

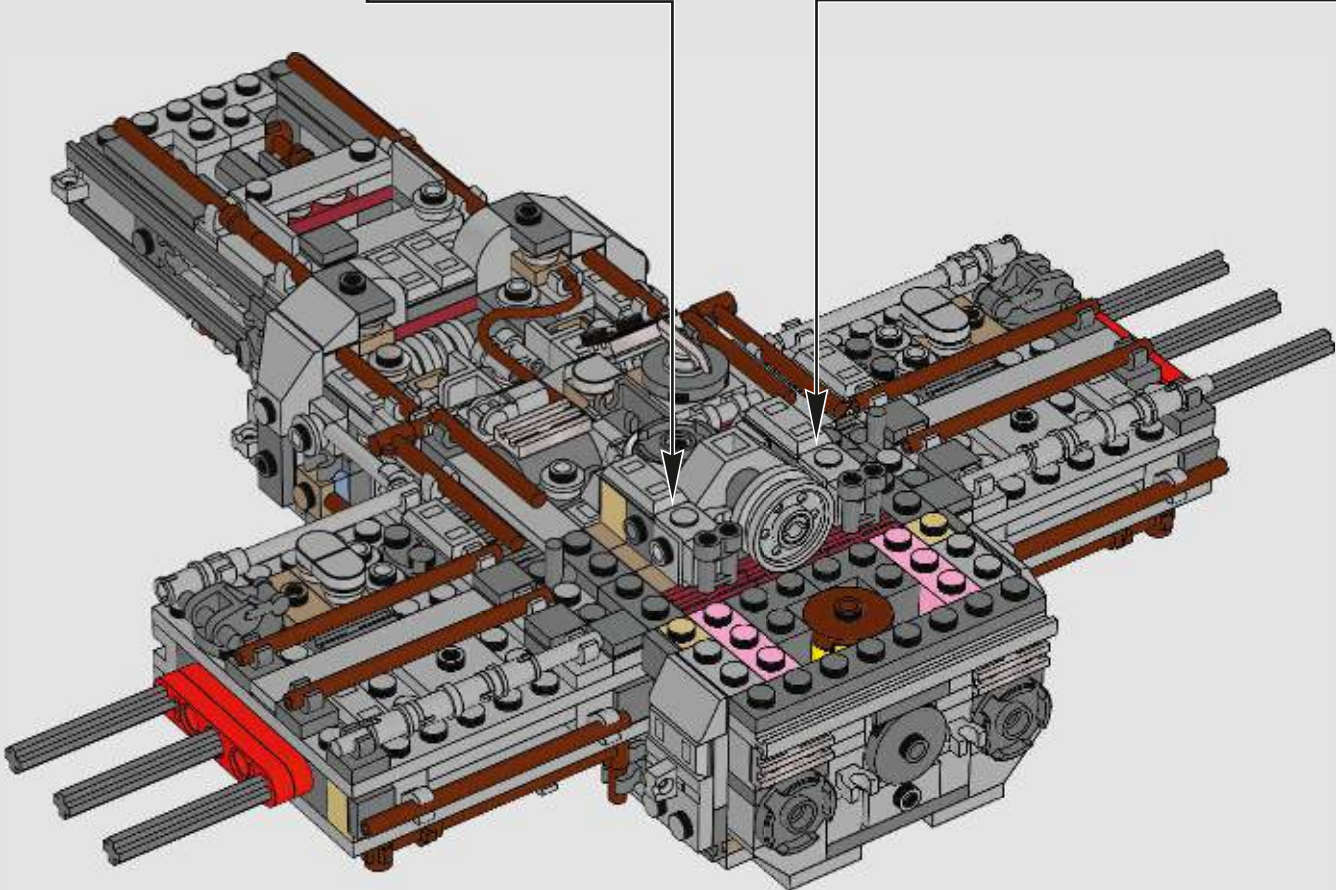
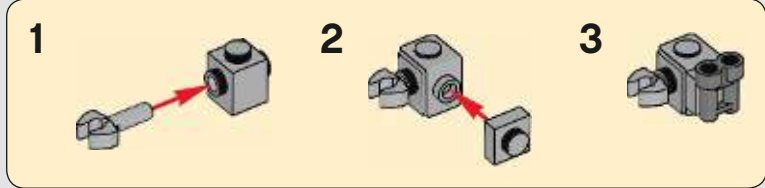
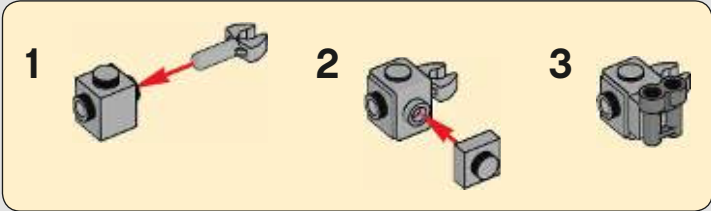



129

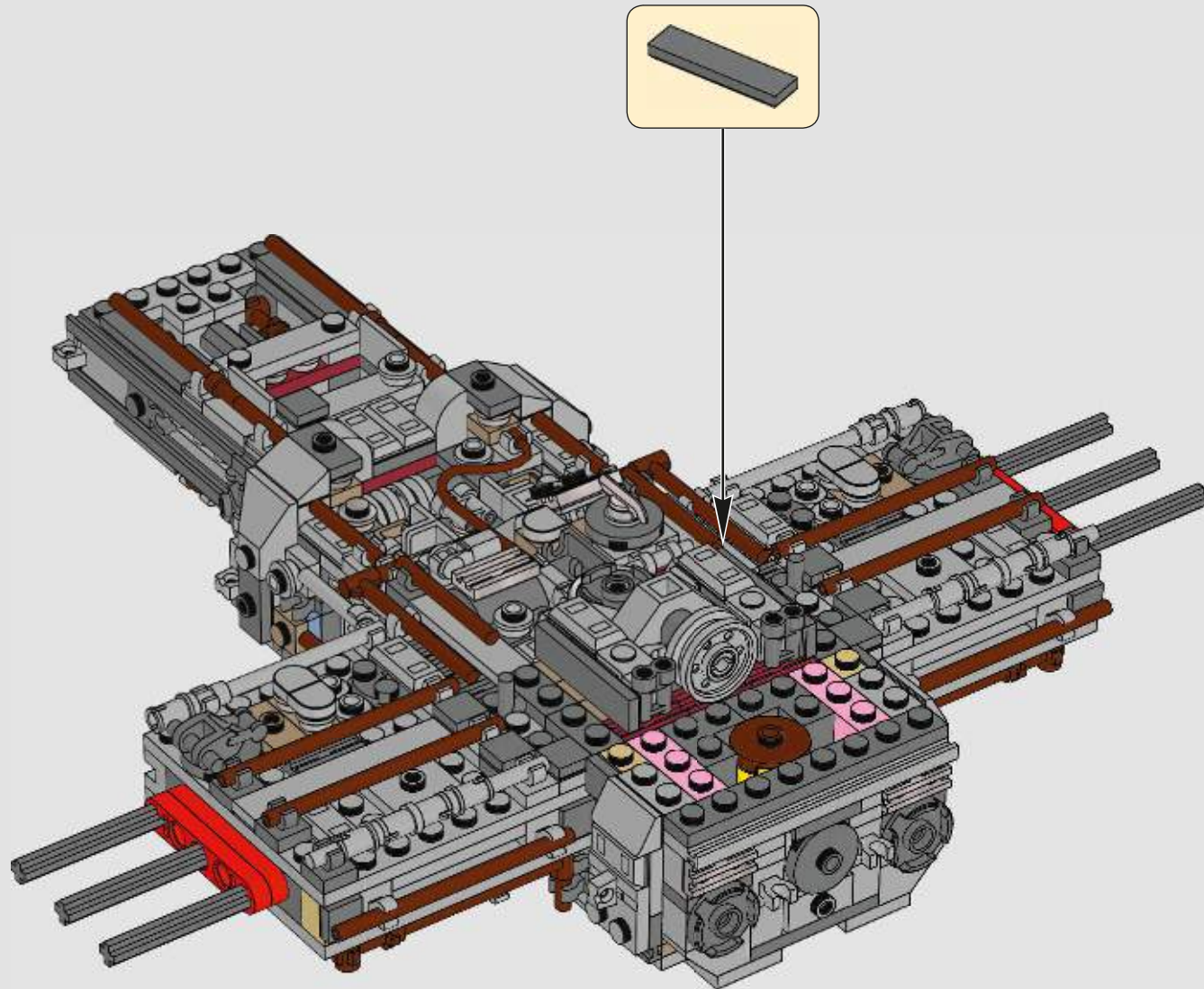

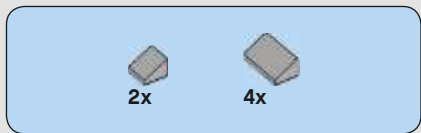

130

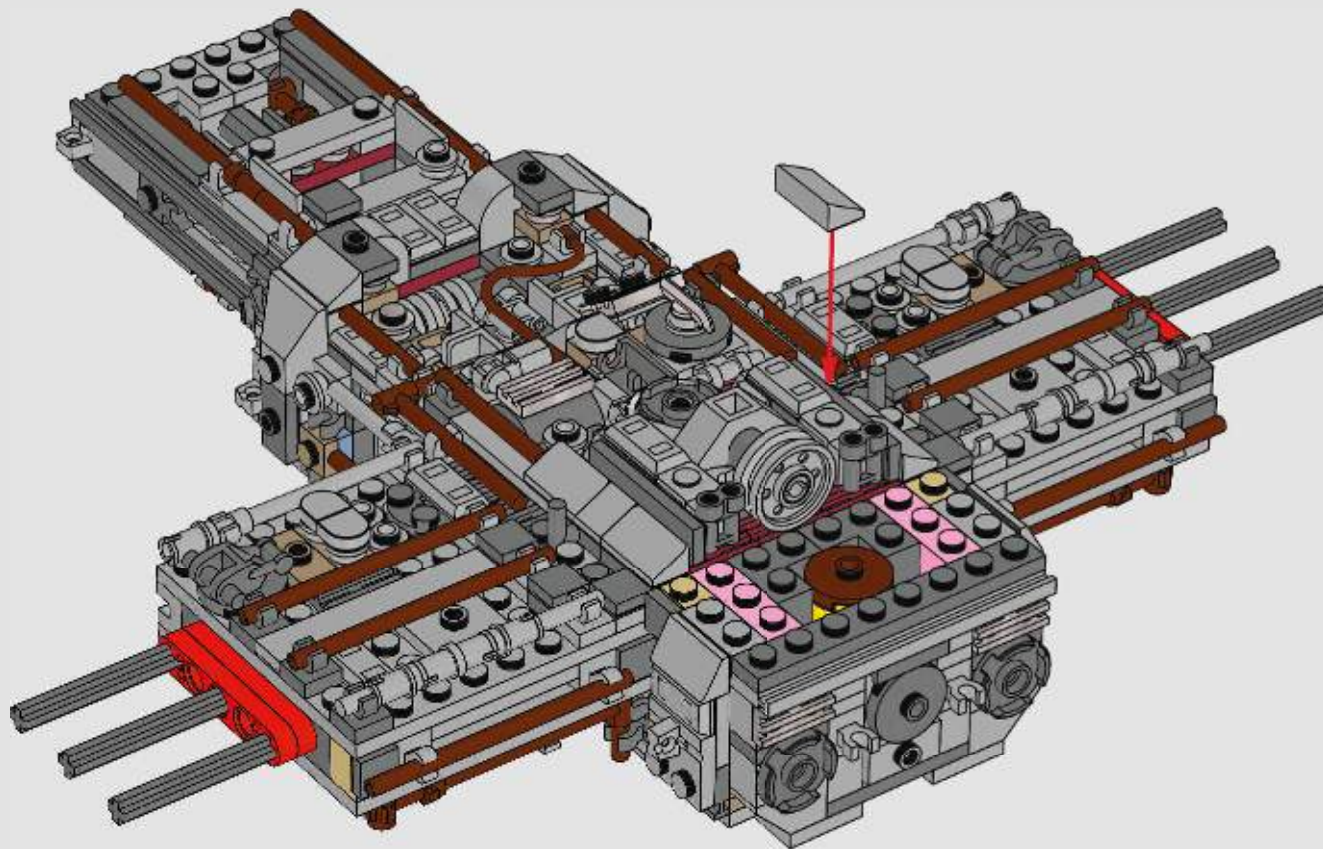

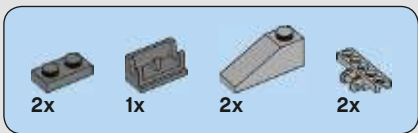

131

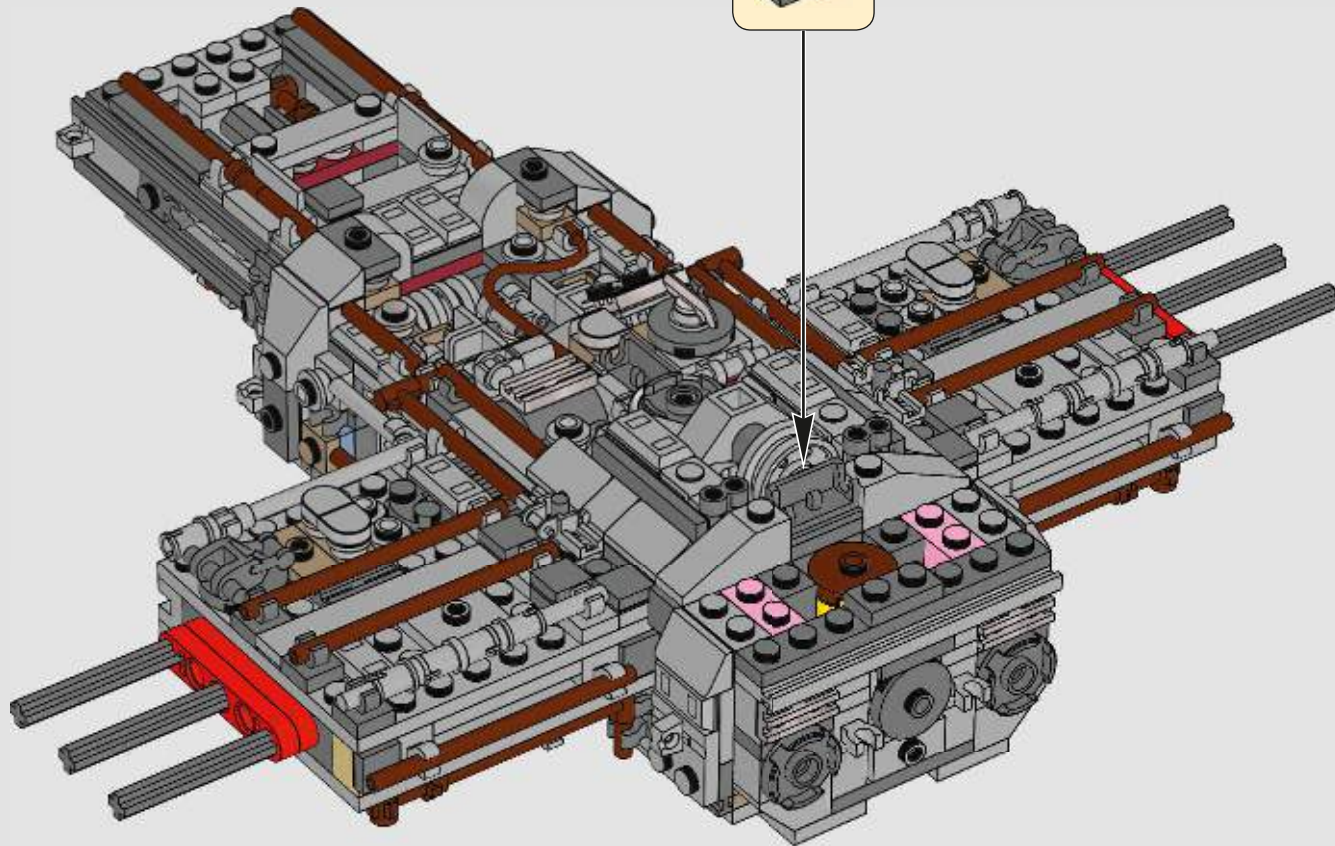
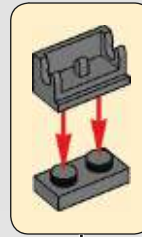

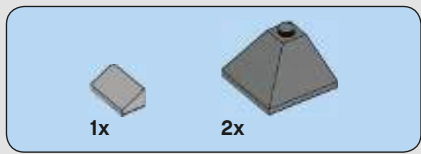

132

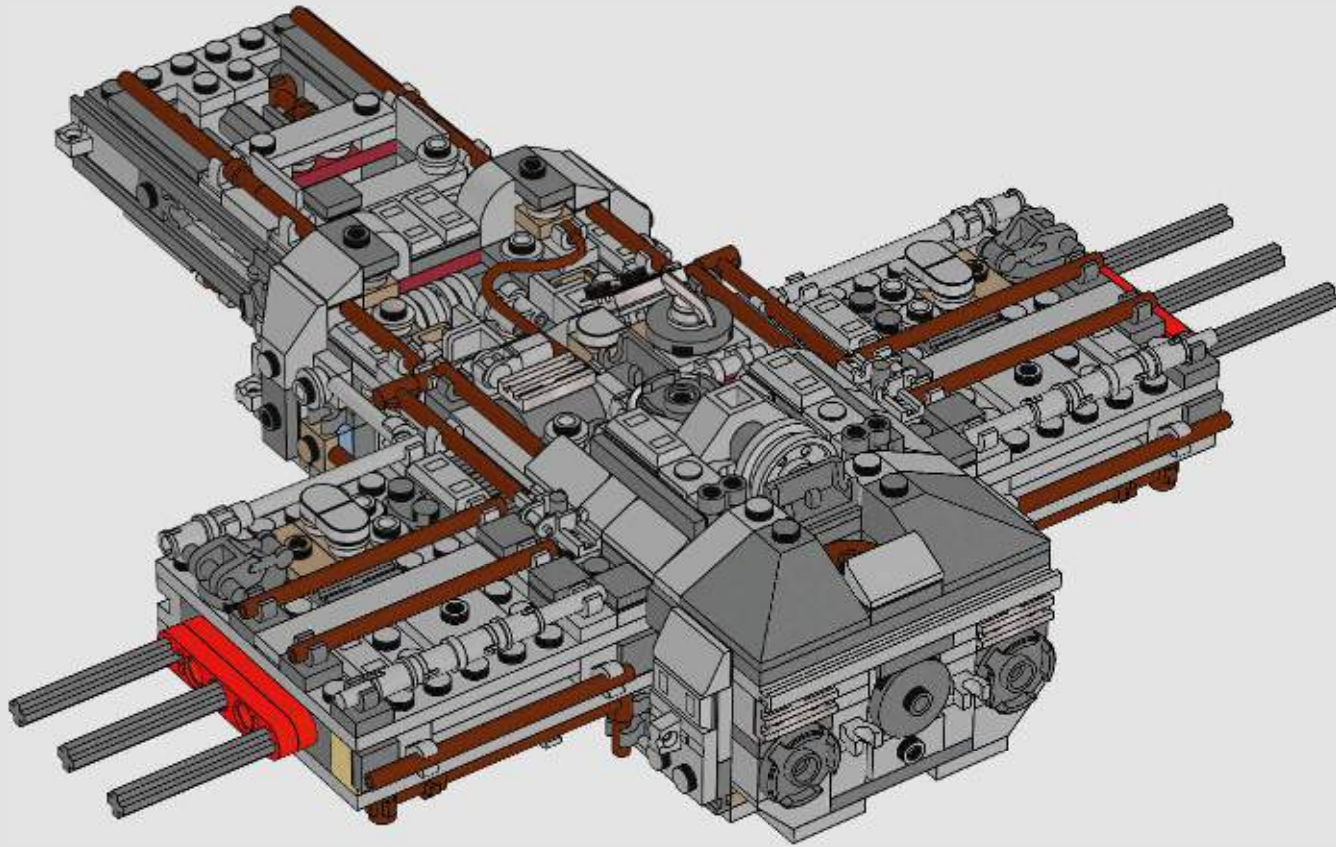

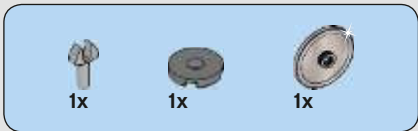

133

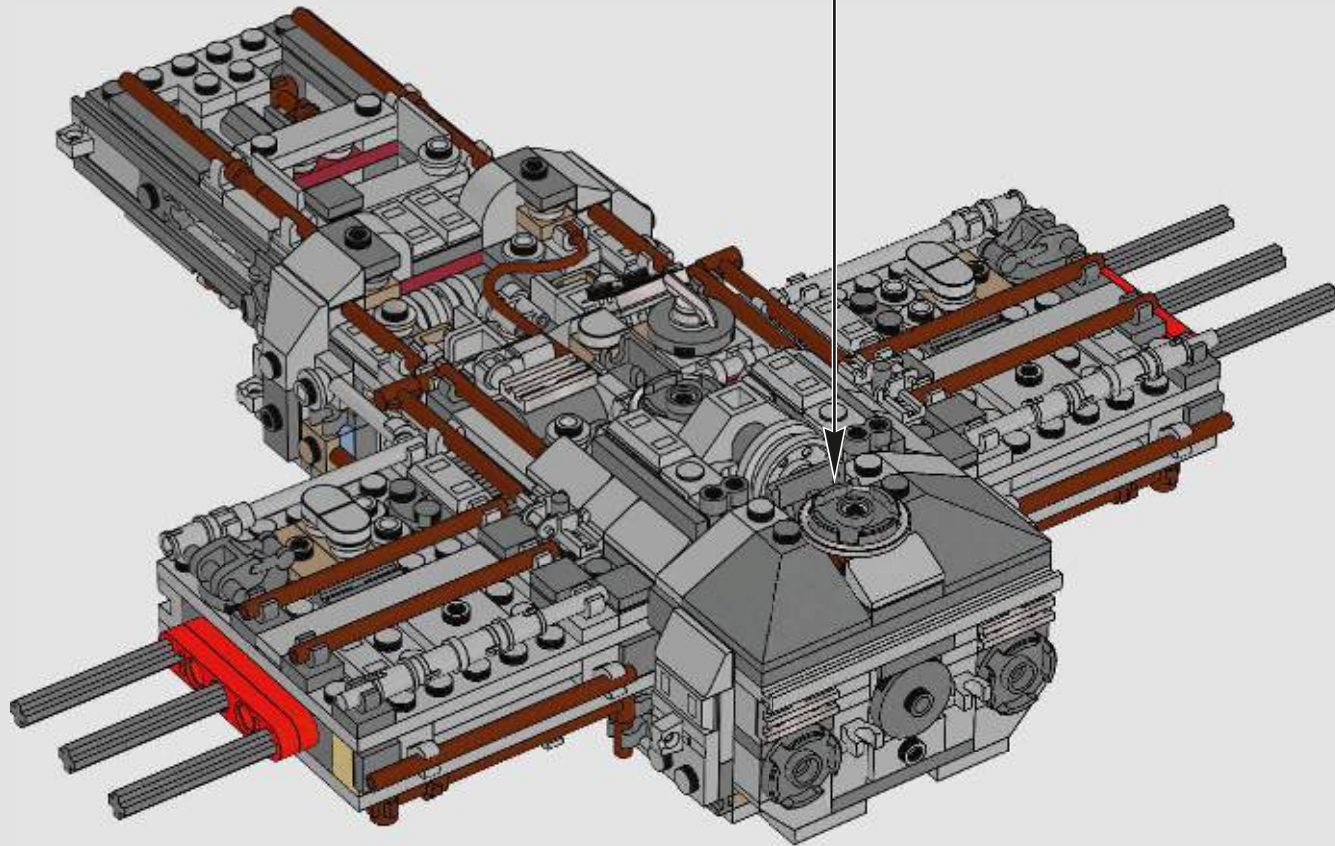
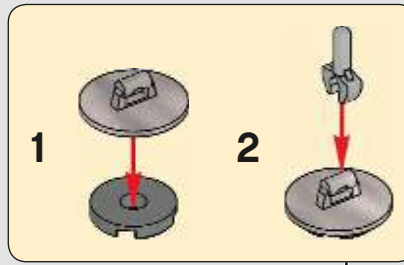

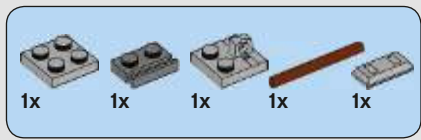

134

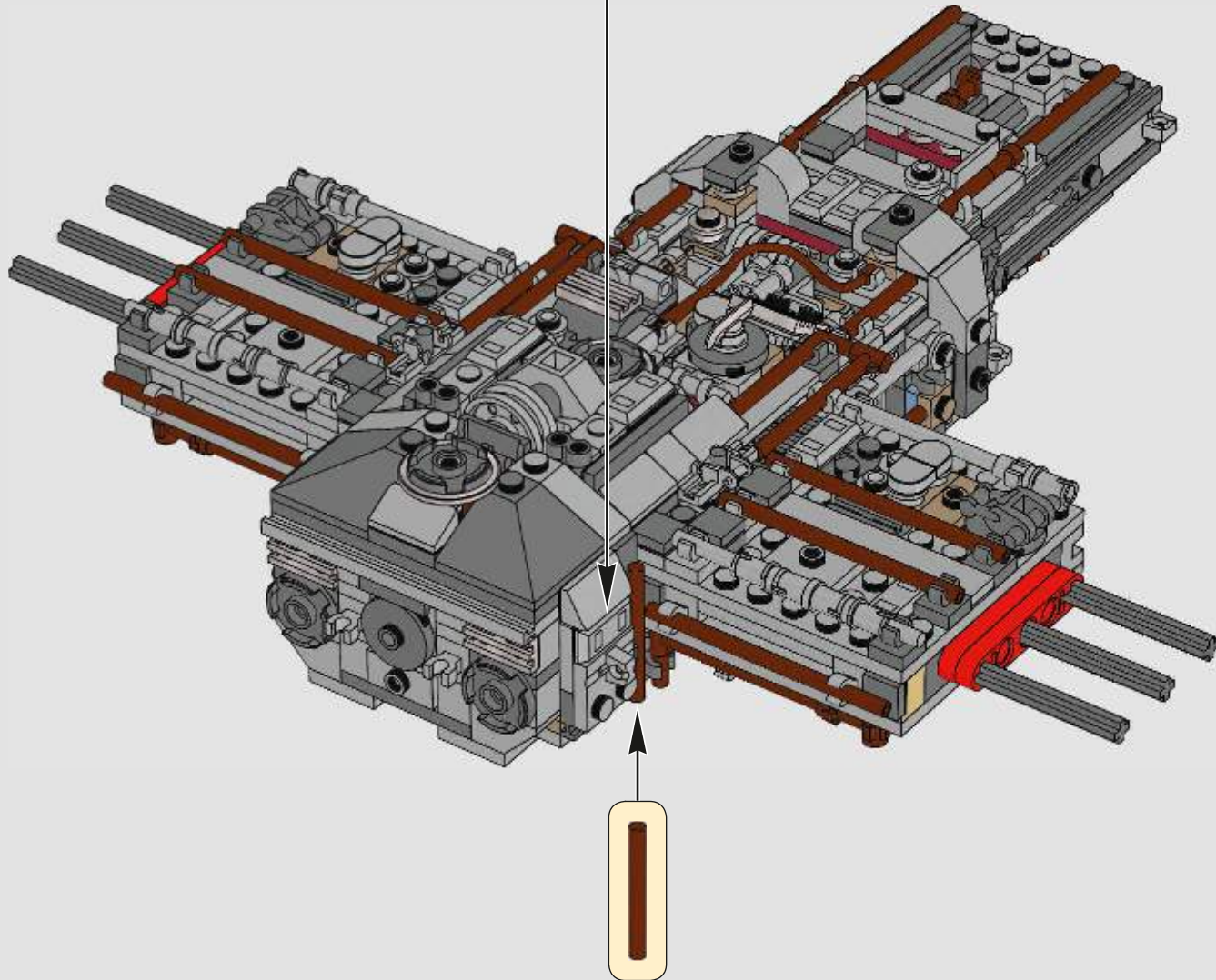



135

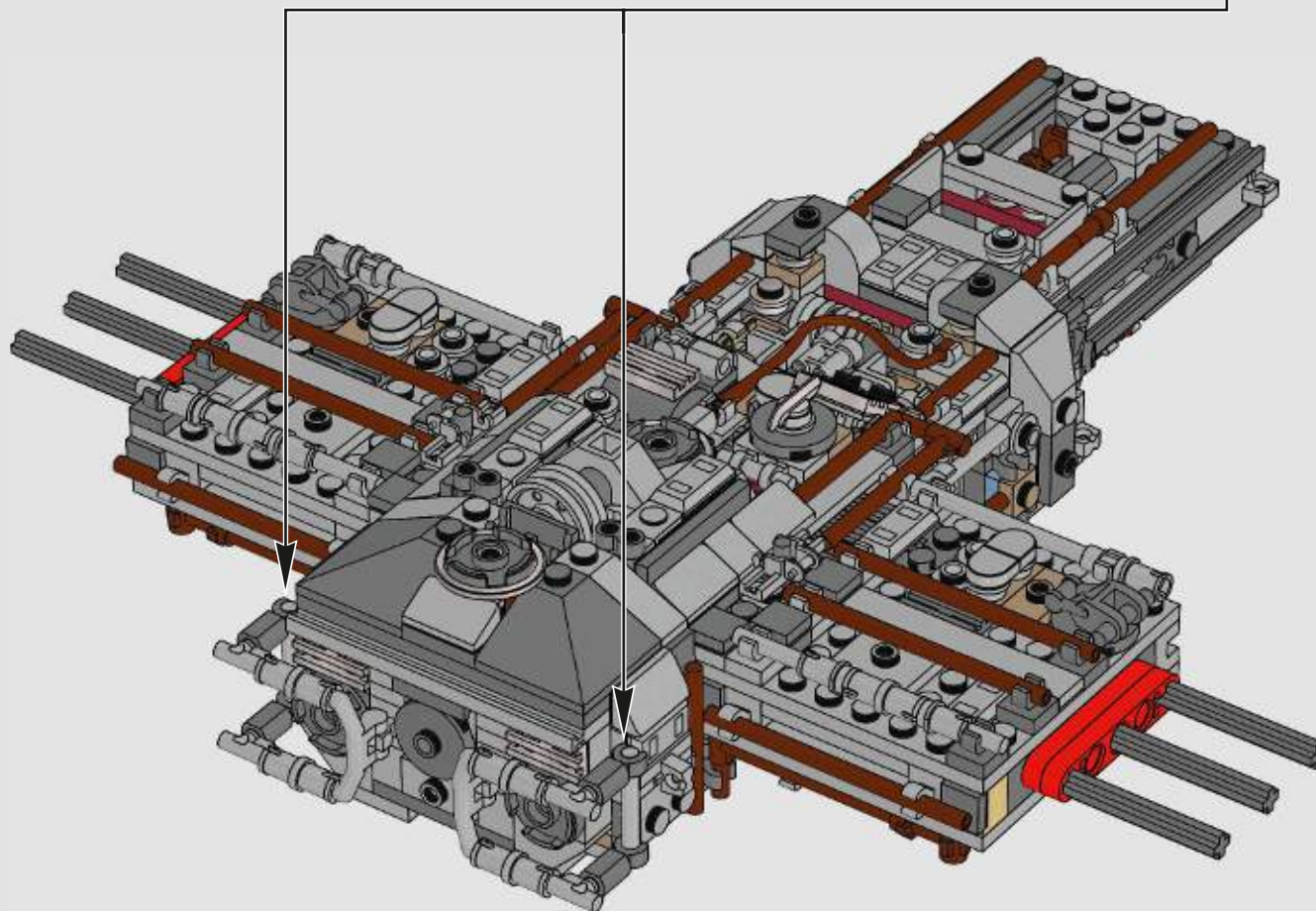
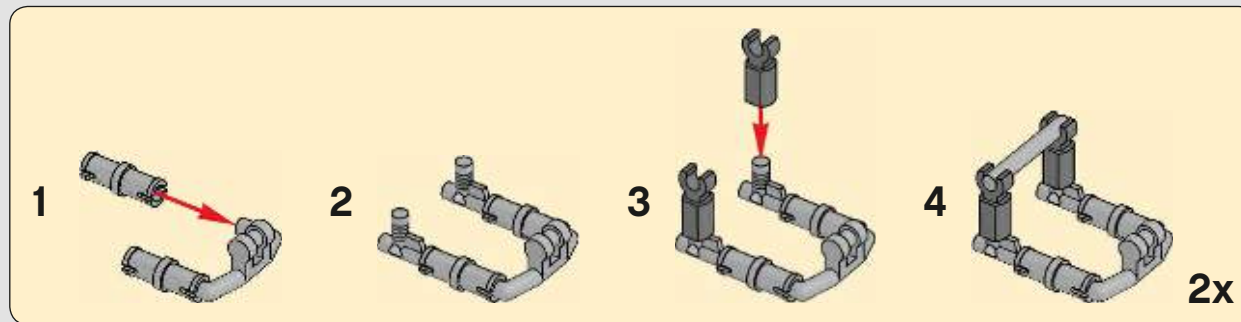



136

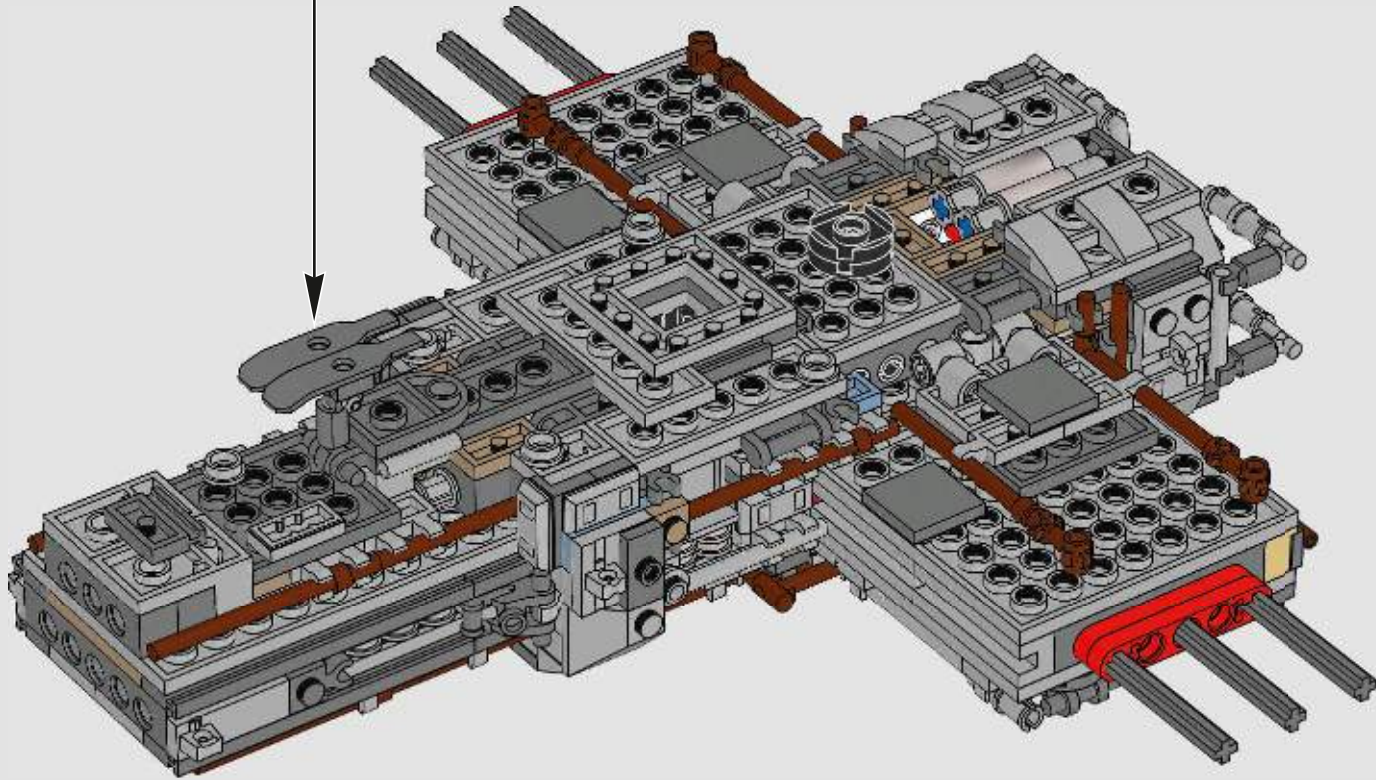
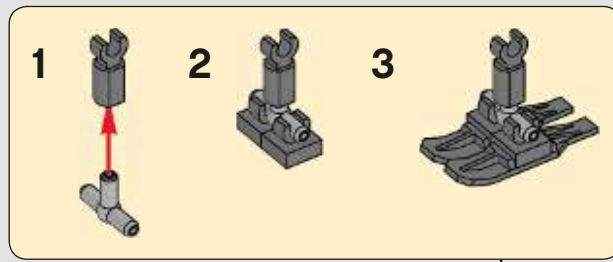

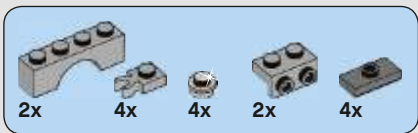

137

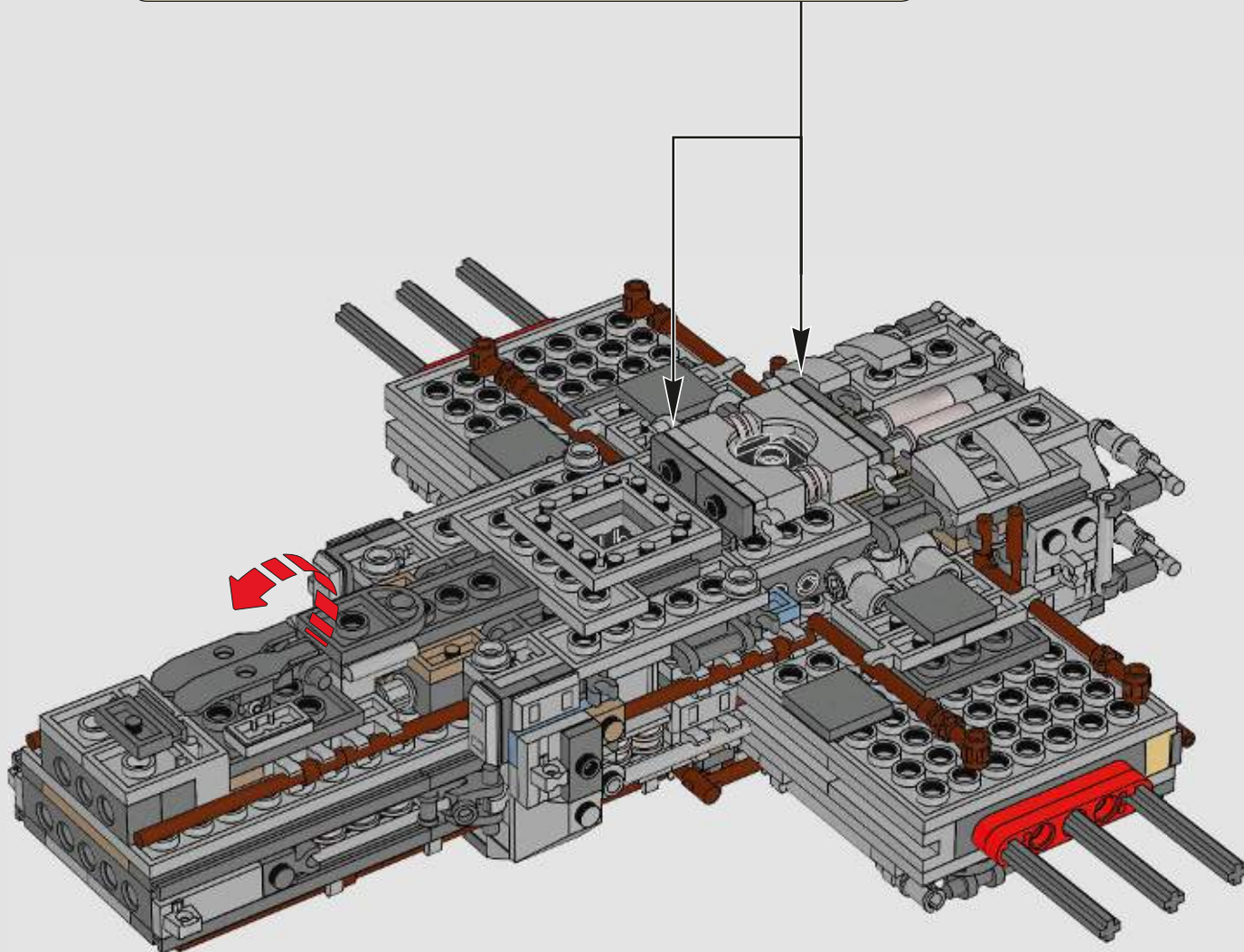
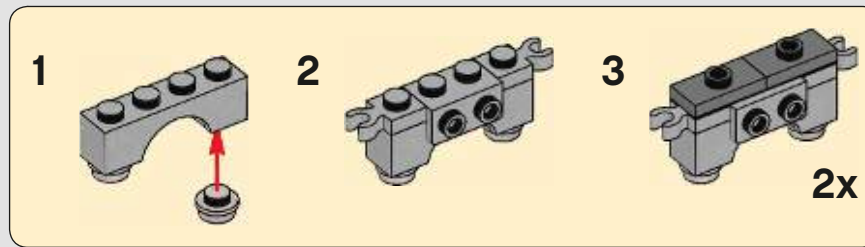



138

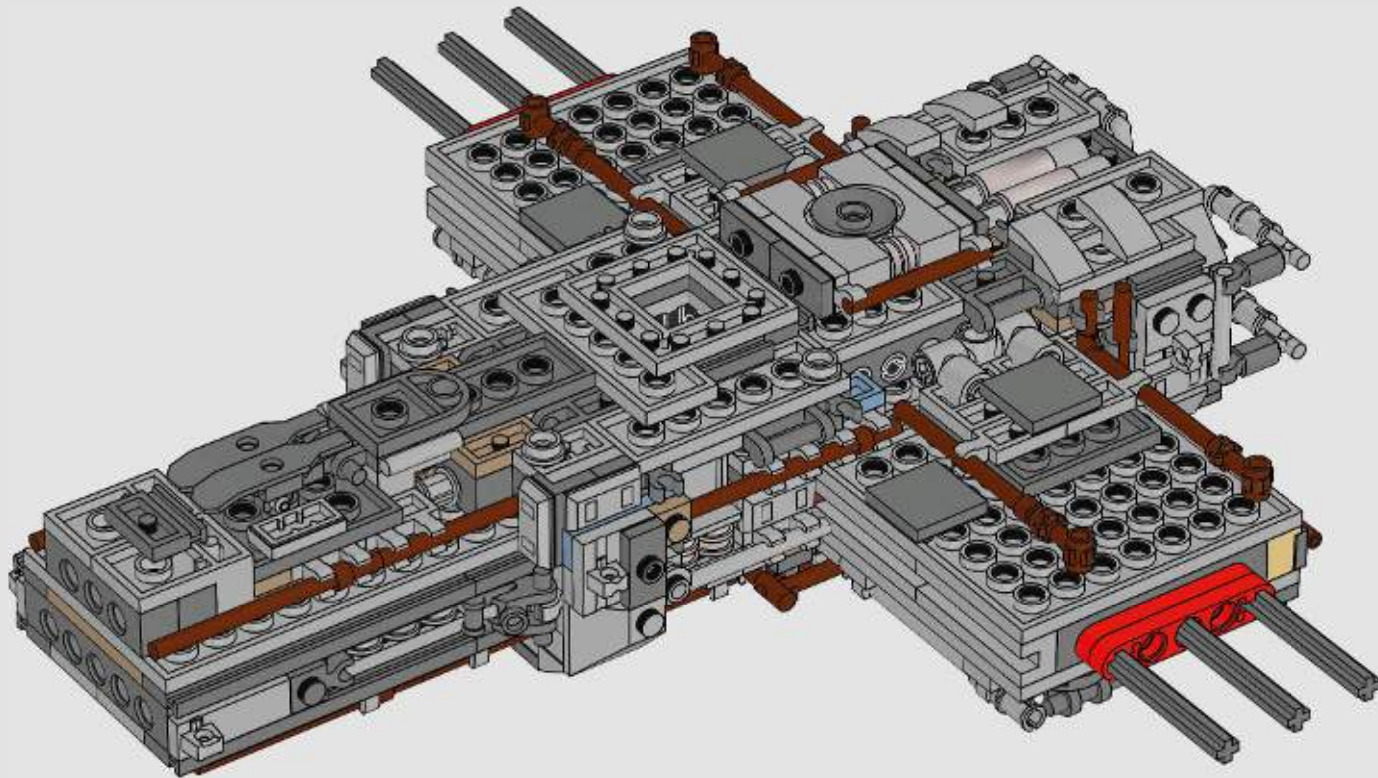

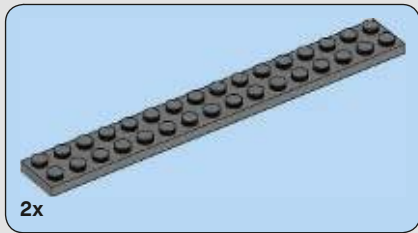
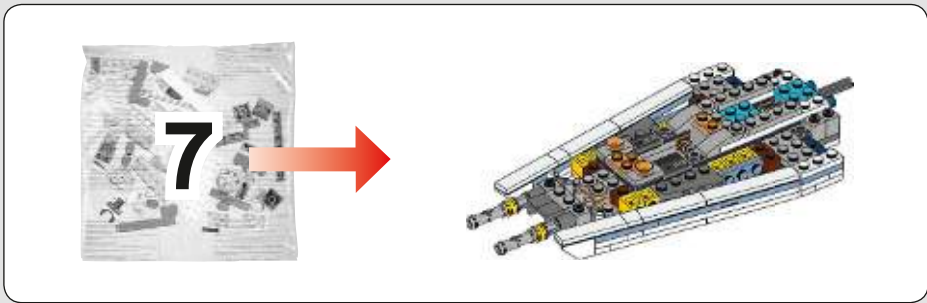

140

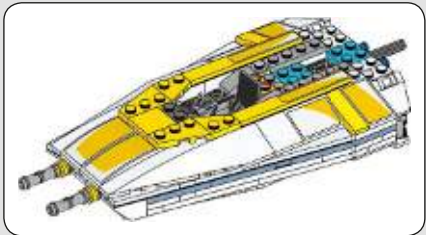

139

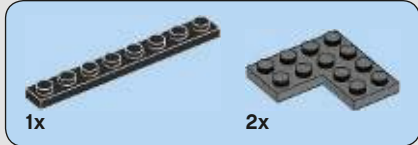
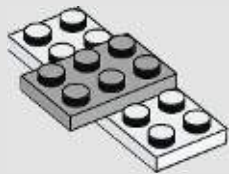

141

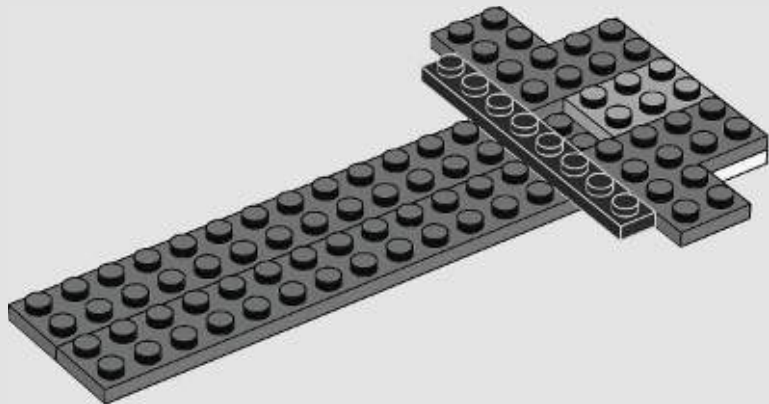



142

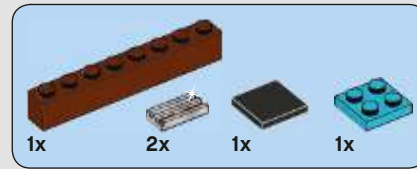
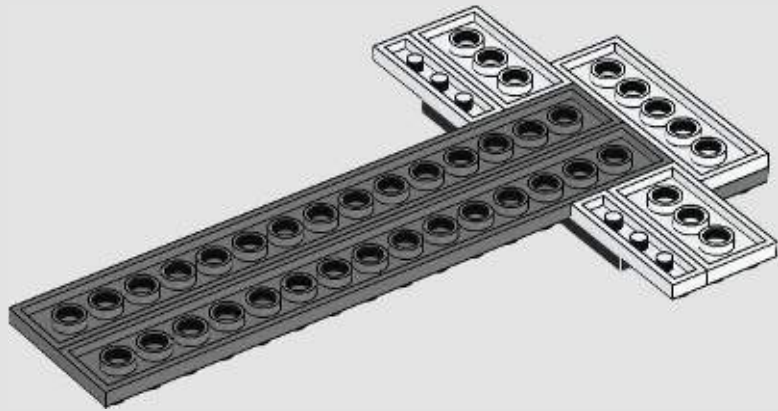

143

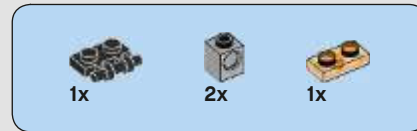
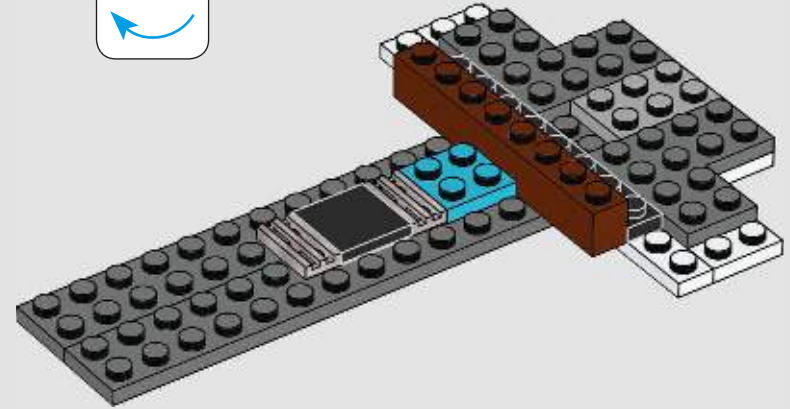

144

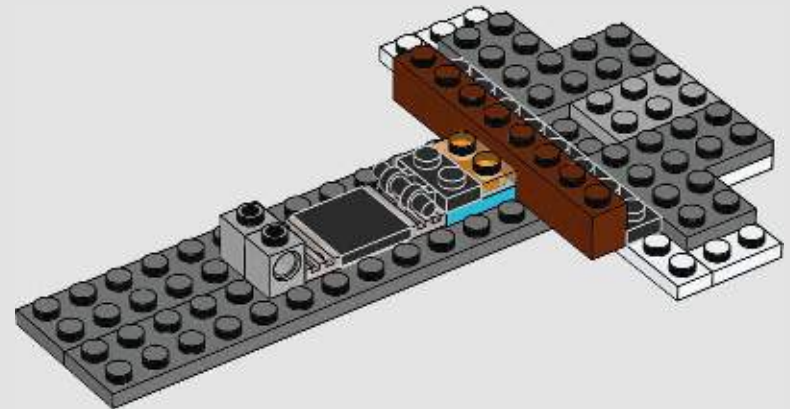



2x



6x

145

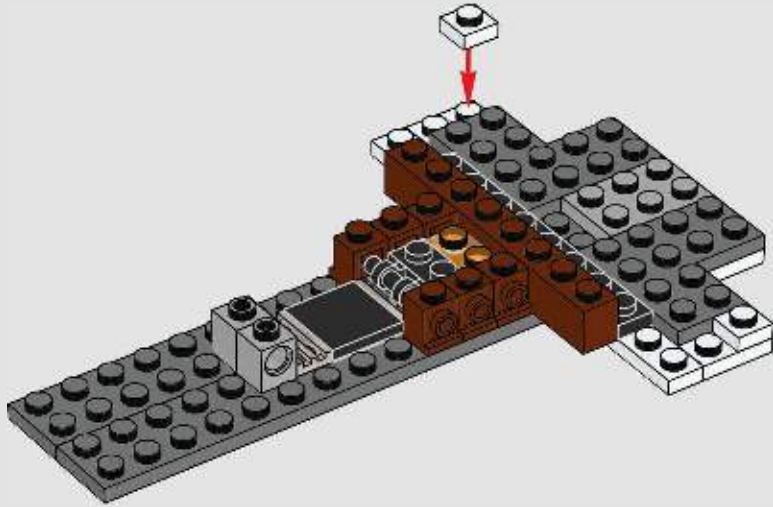

6x



4x

146

1

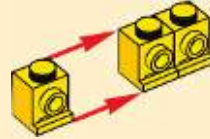

2



3



2x

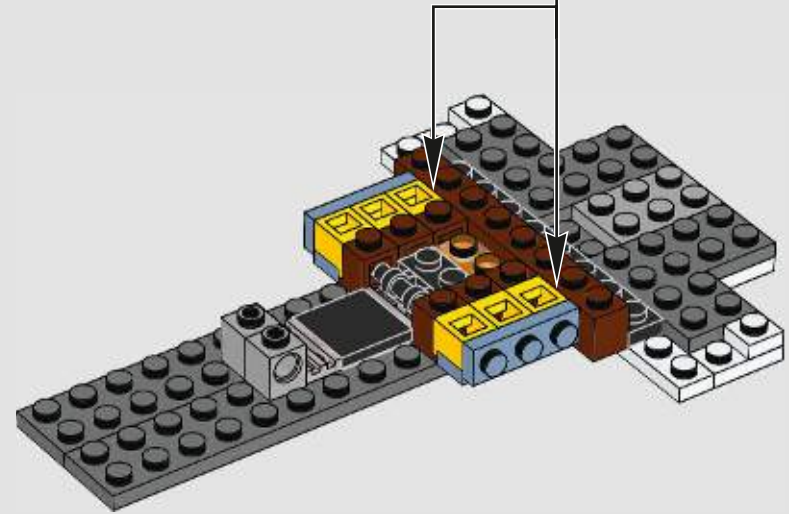

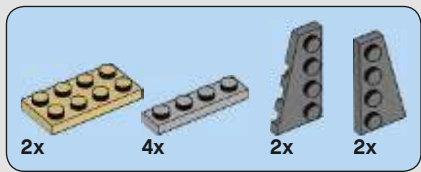

147

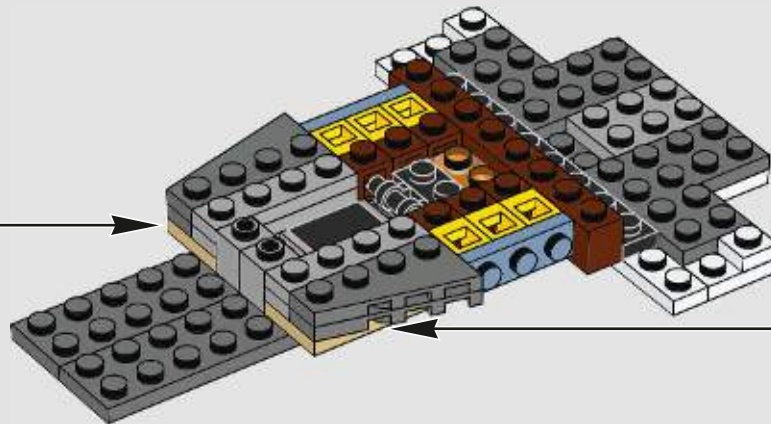
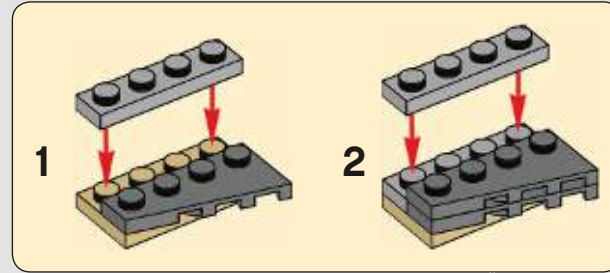
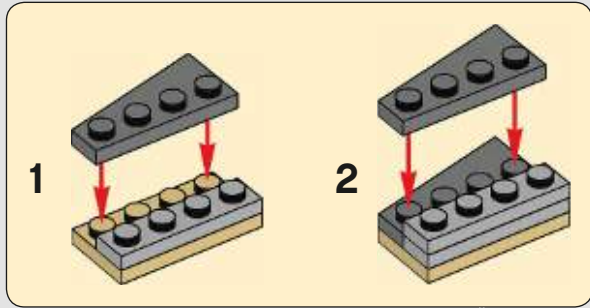

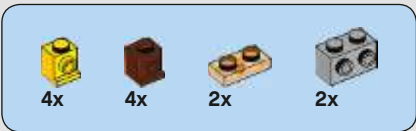

148

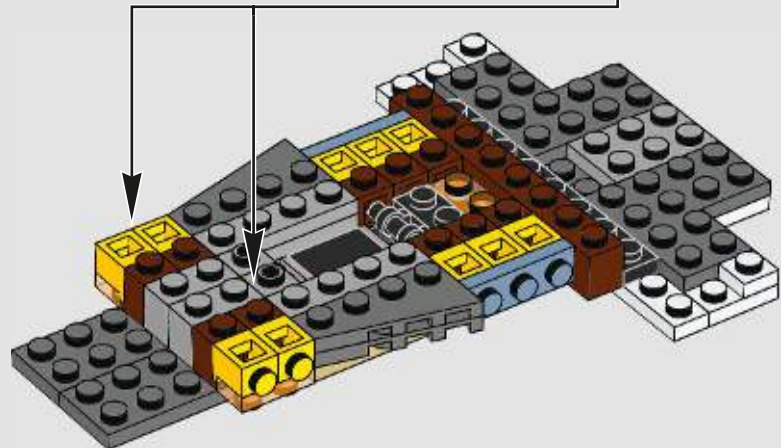

149

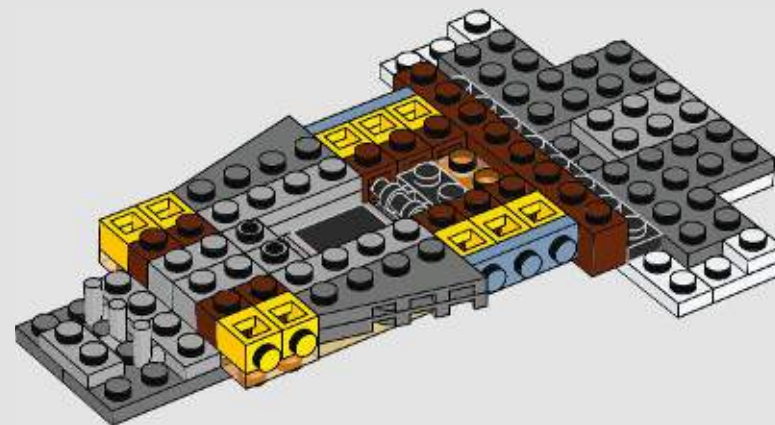

150

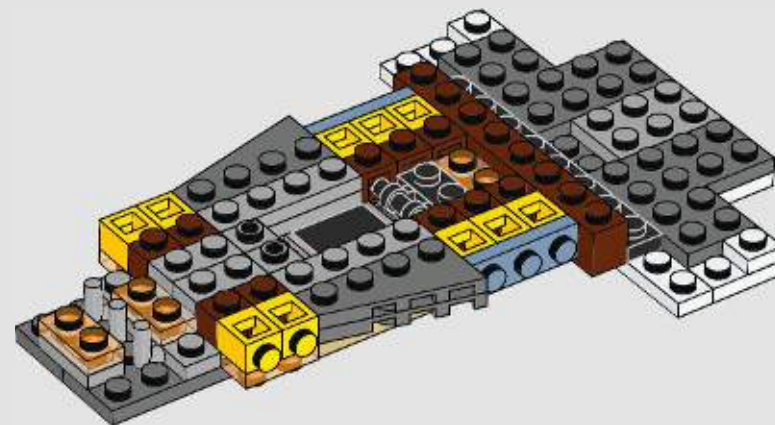

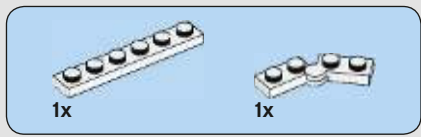

151

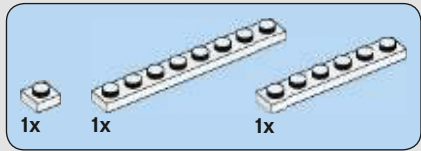
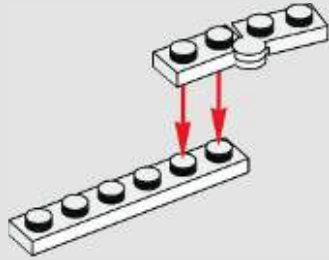

152

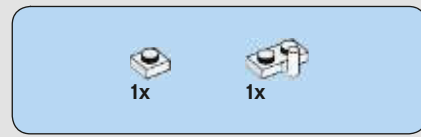
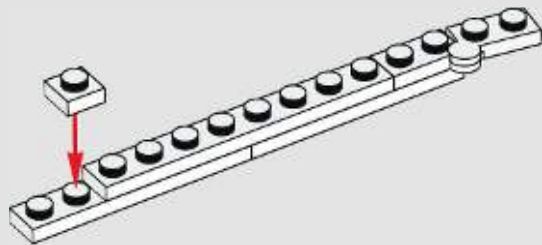

153

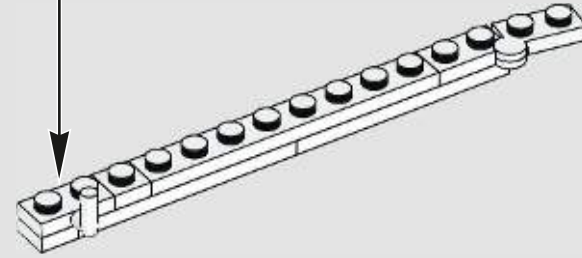
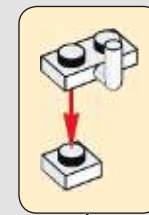

154

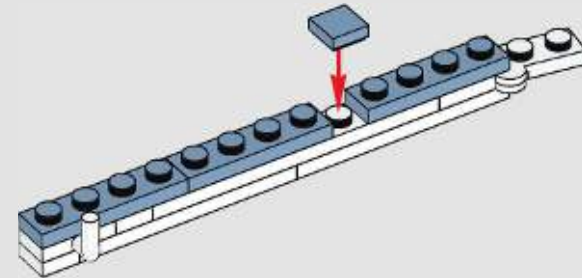

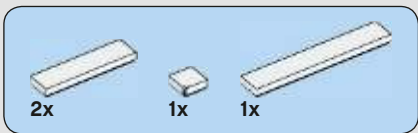

155

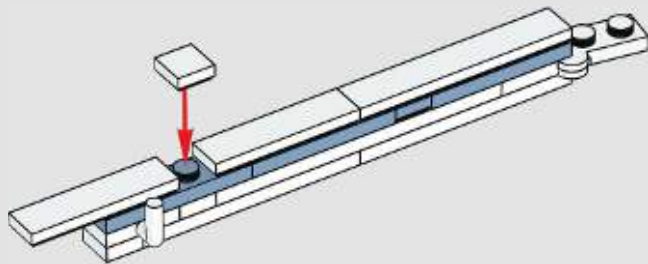

156

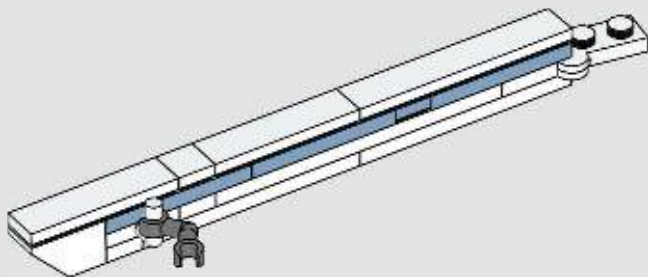

157

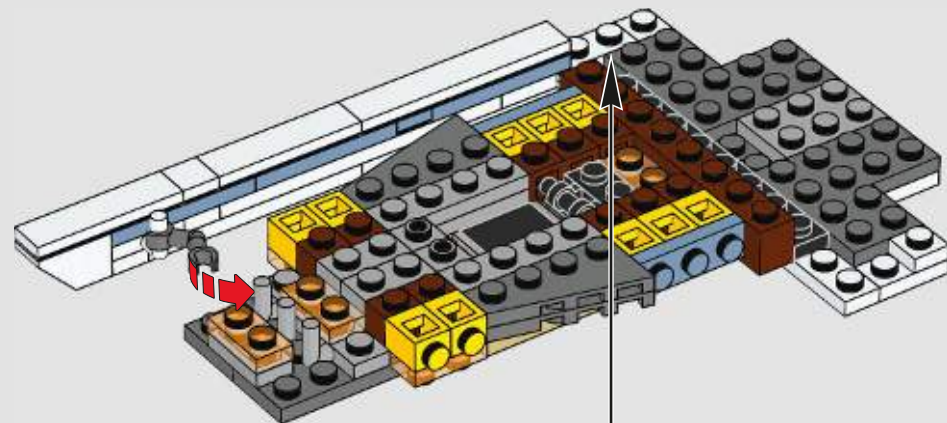

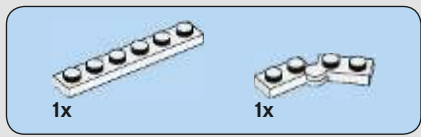

158

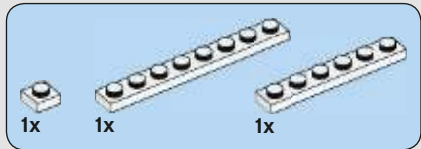
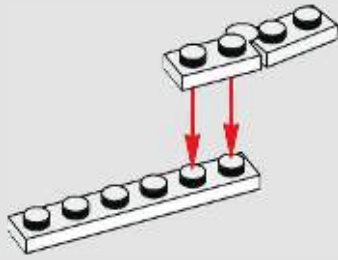

159

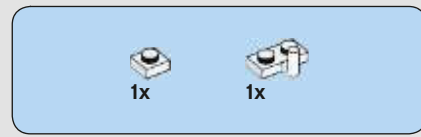
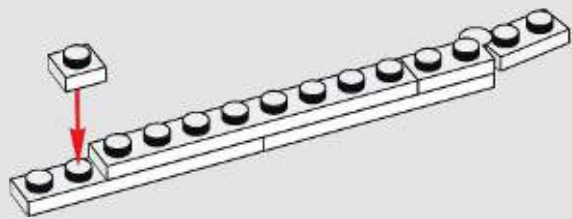

160

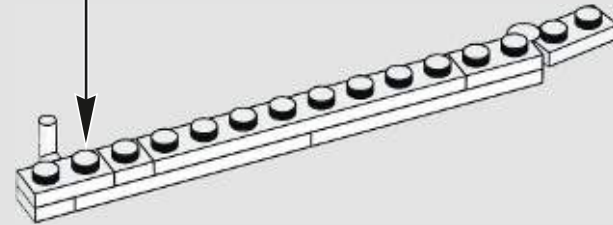
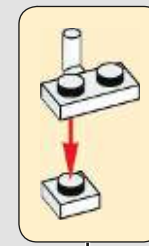

161

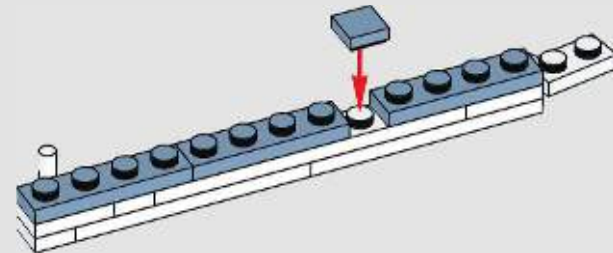

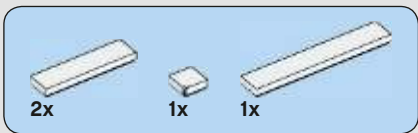

162

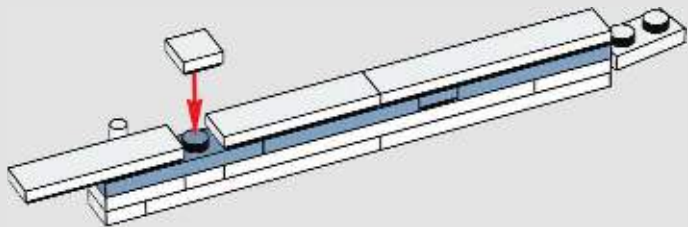

163

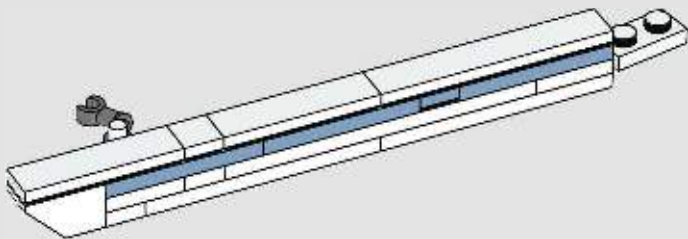

164

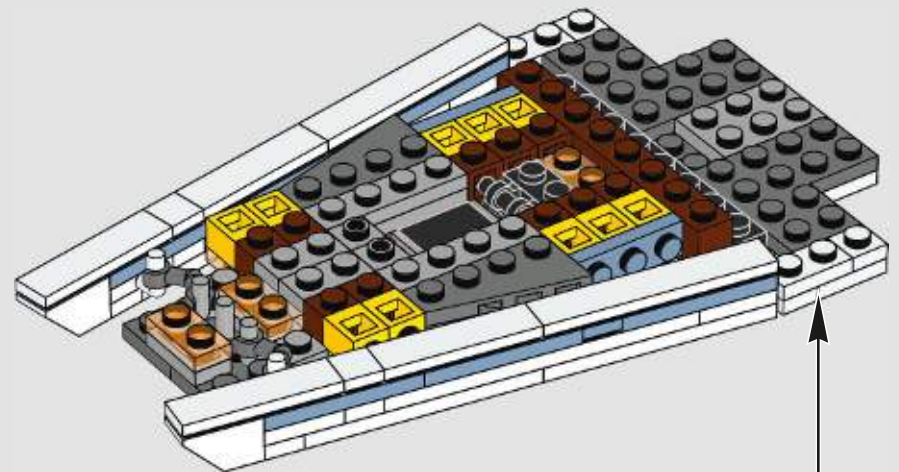



165

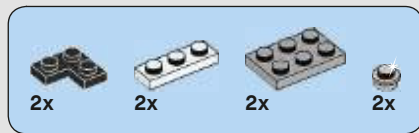
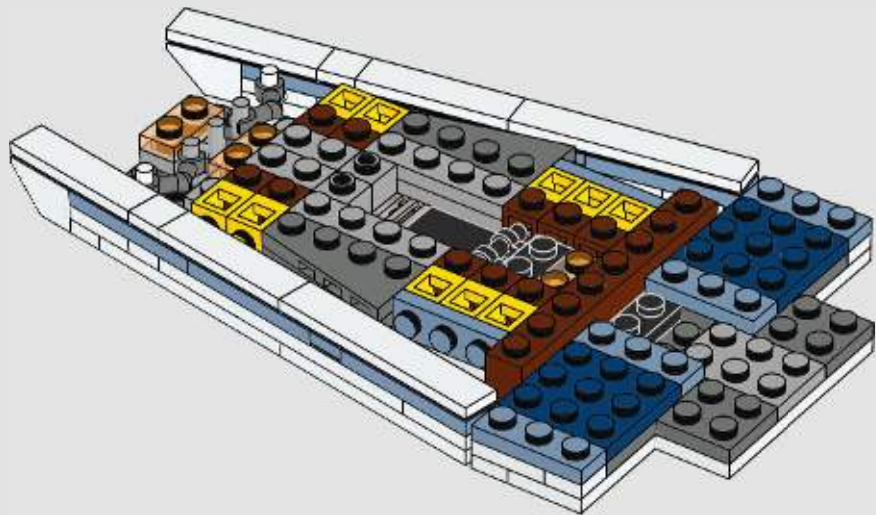

166

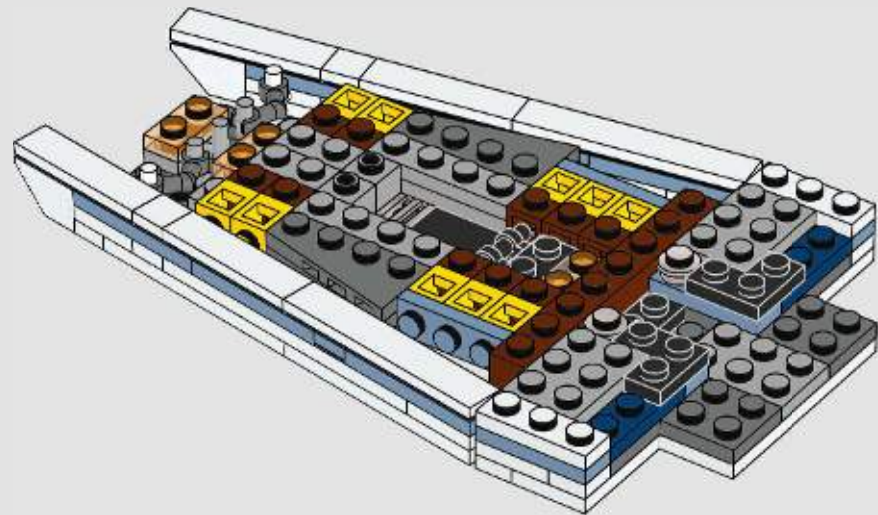

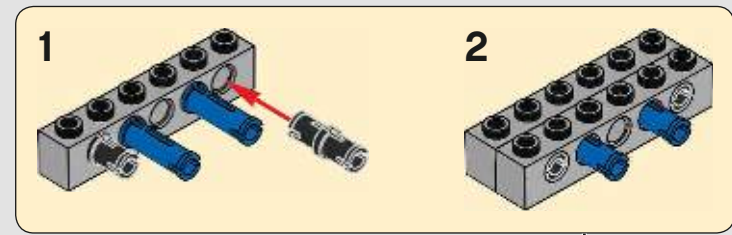
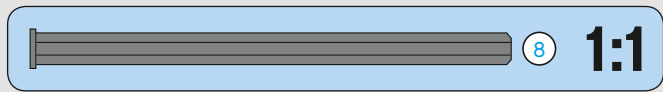
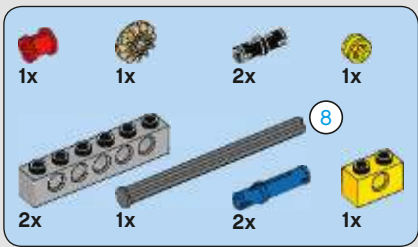

167

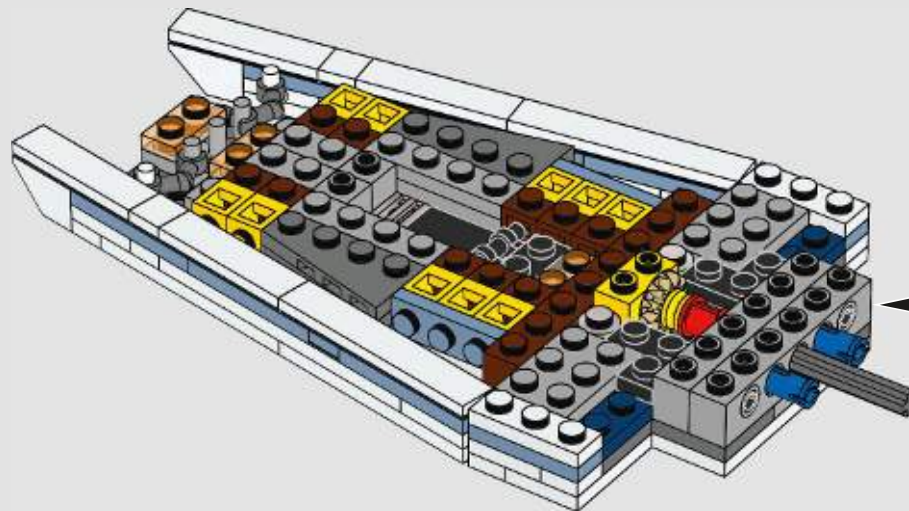
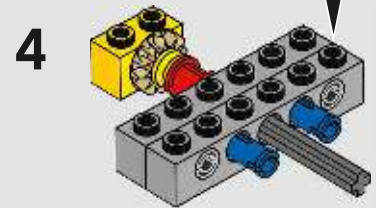
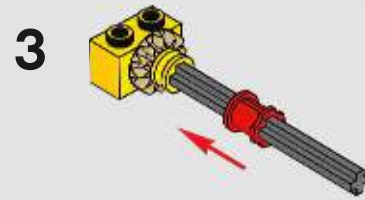
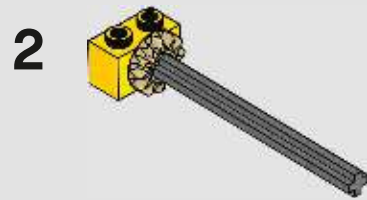
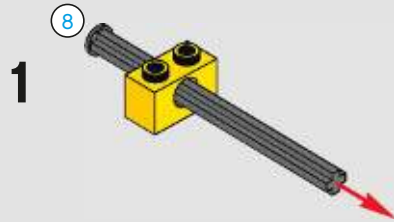

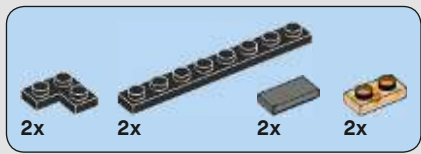

168

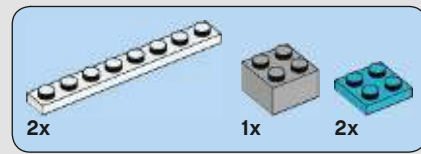
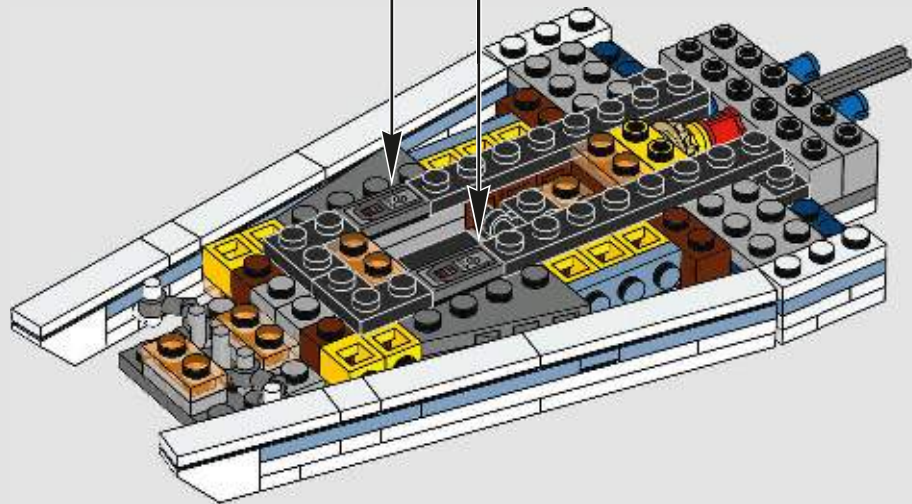
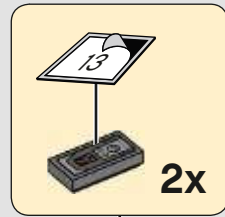

169

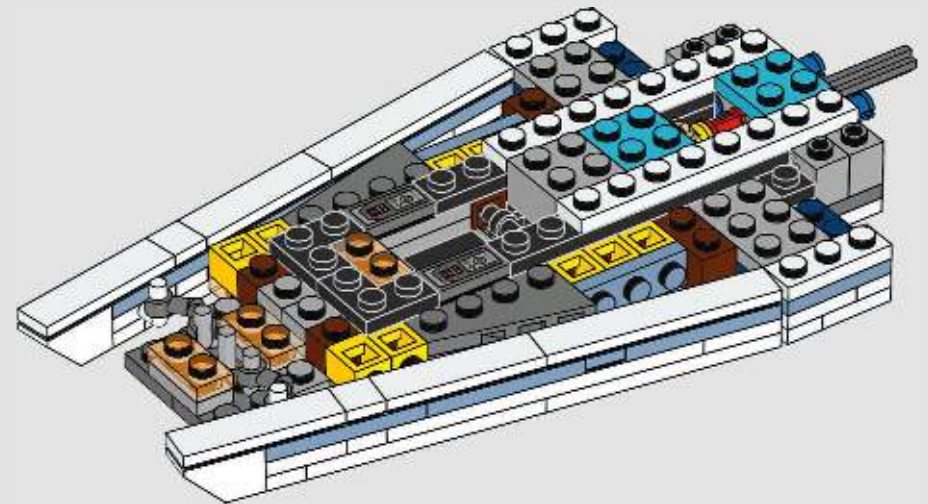

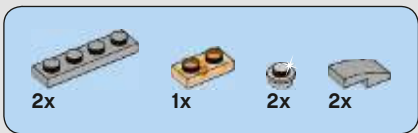

170

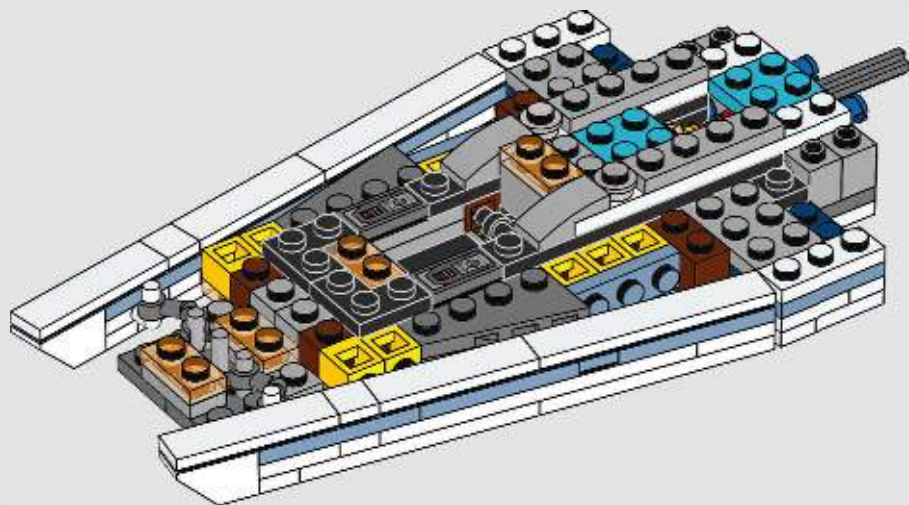

171

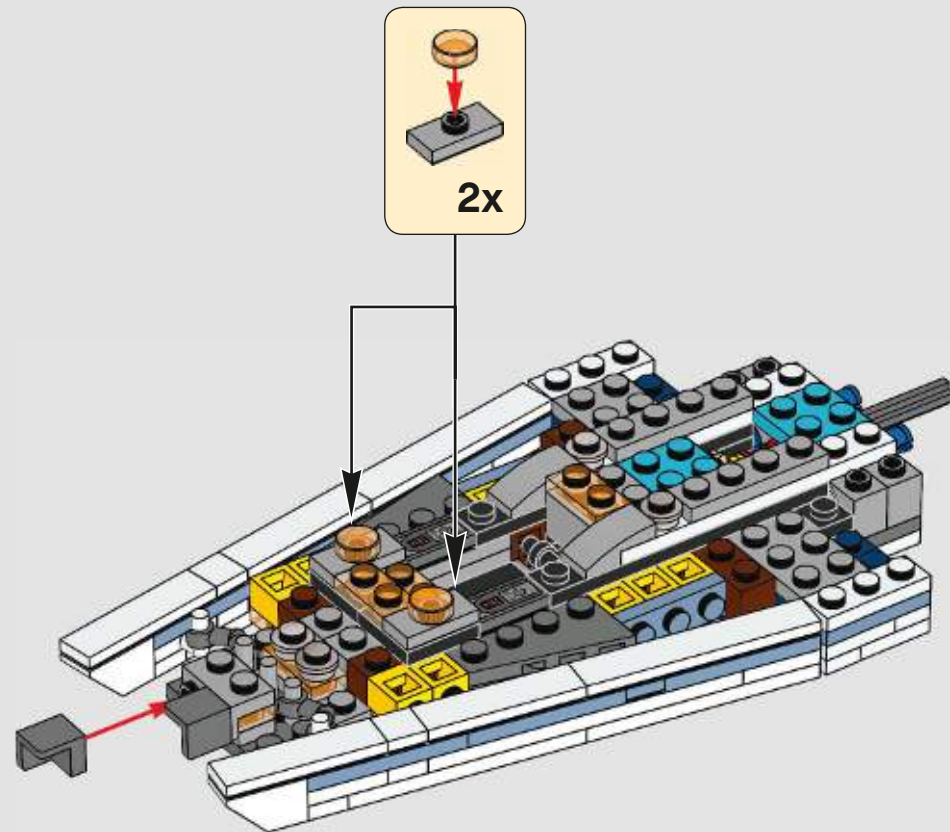



172

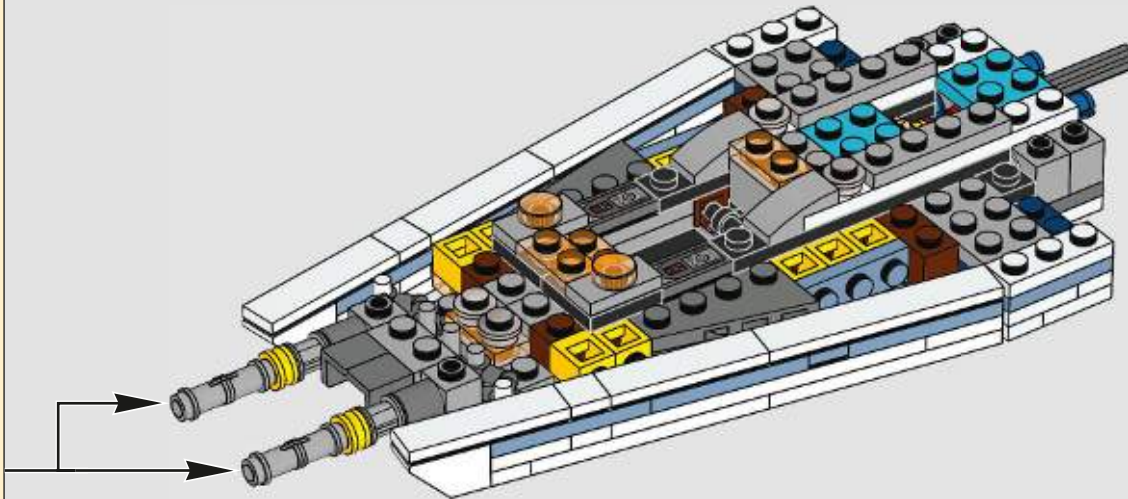
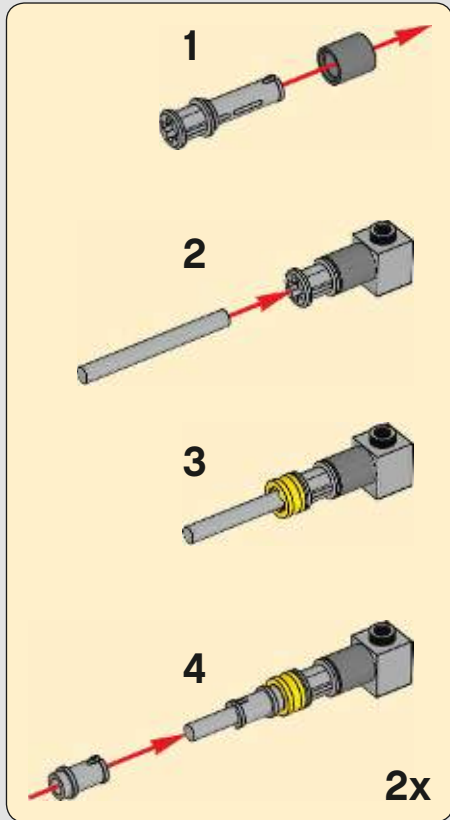

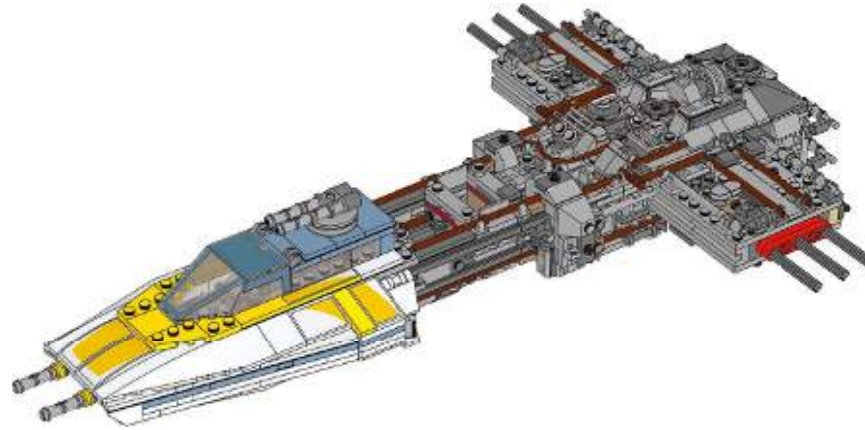

1x



1x

173

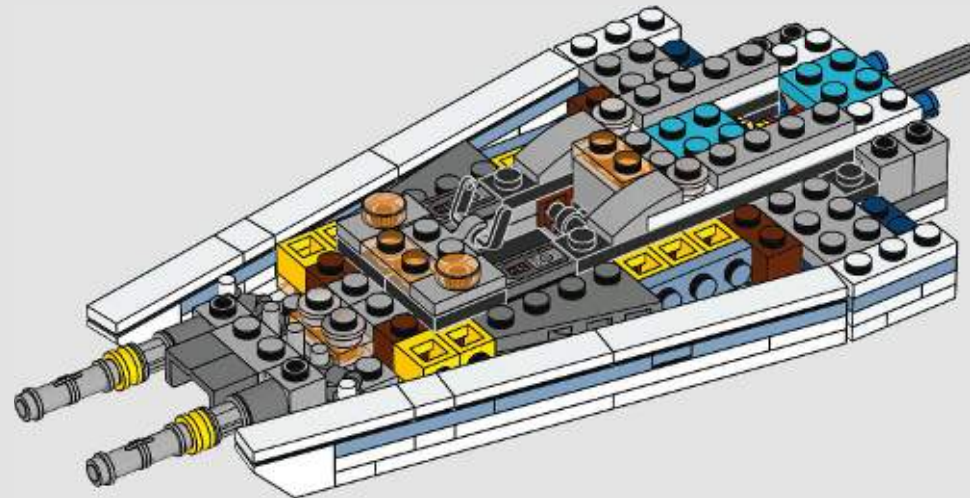

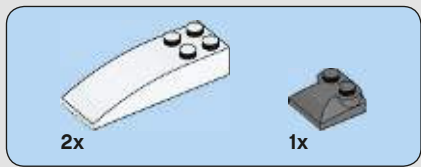

174

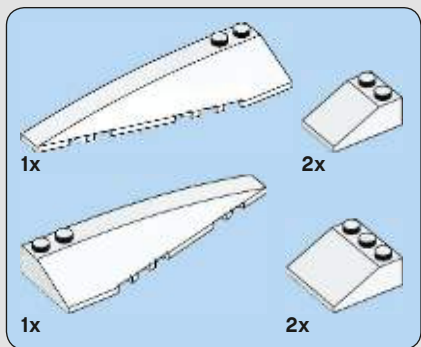
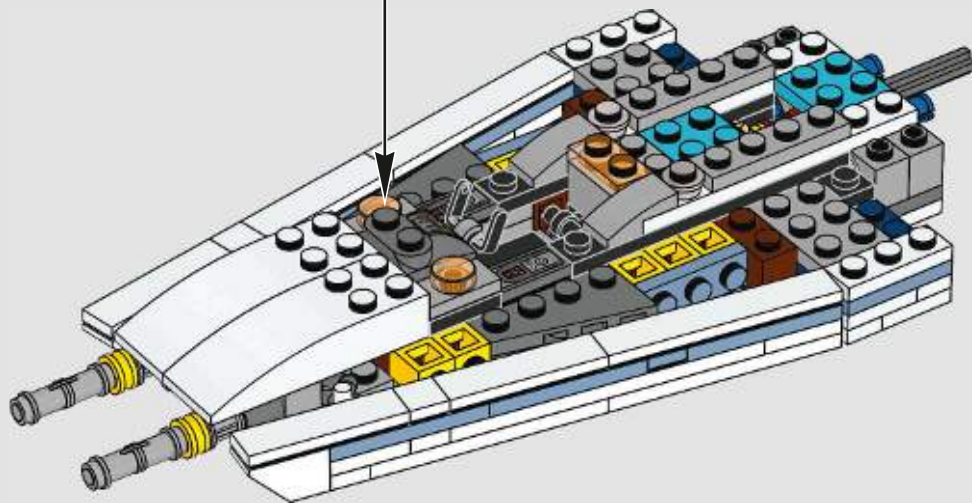

175

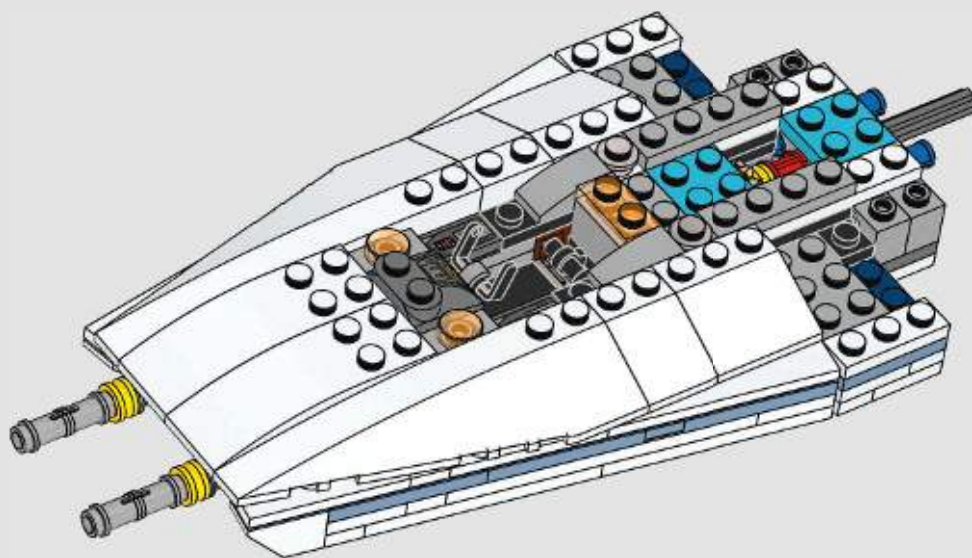

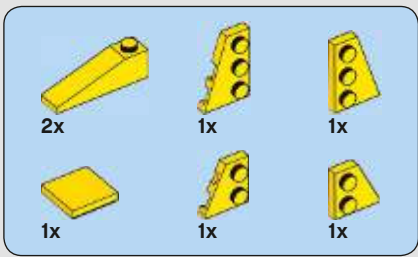

176

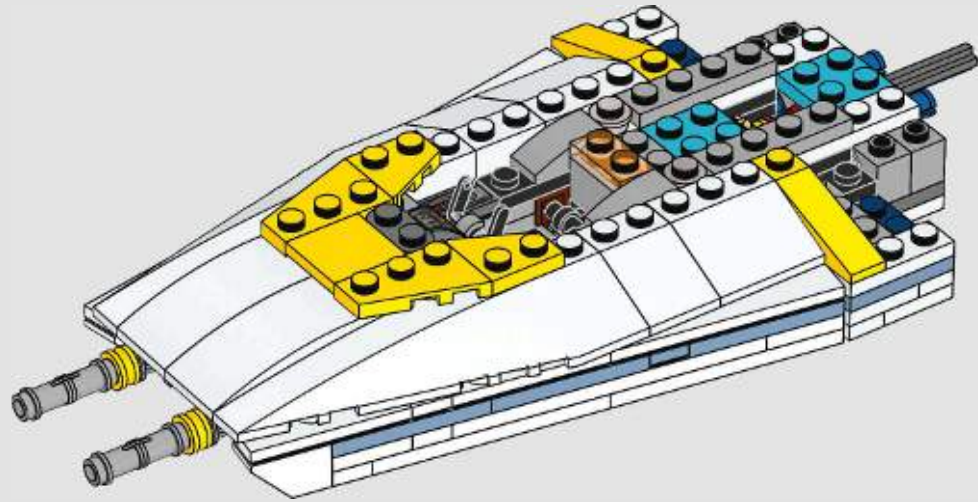

177

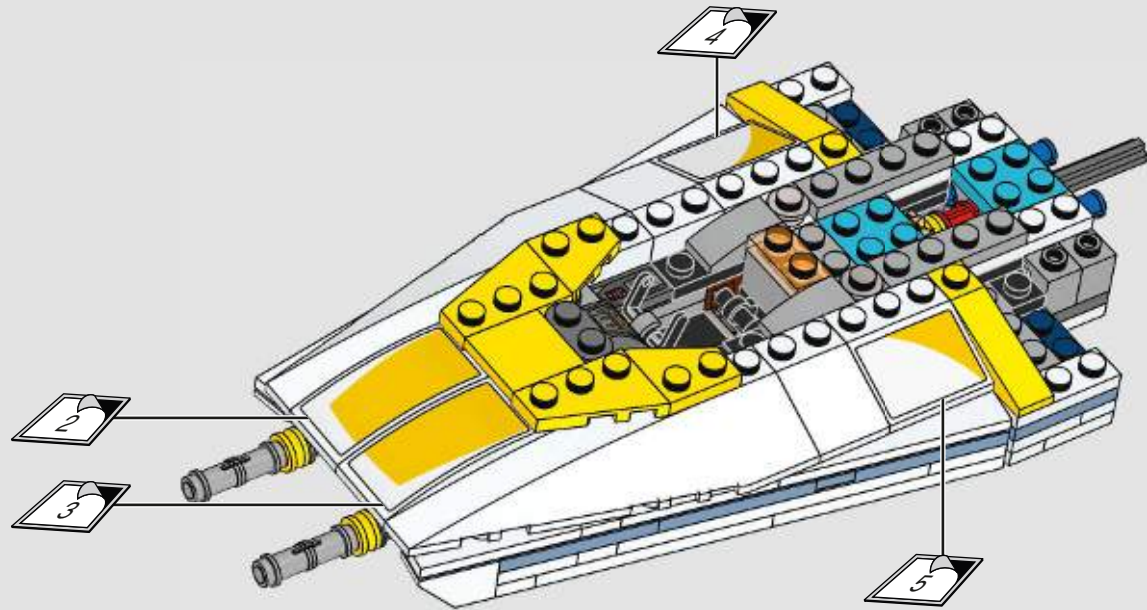

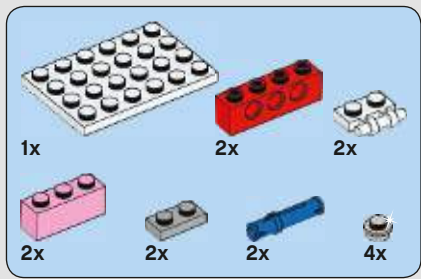

178

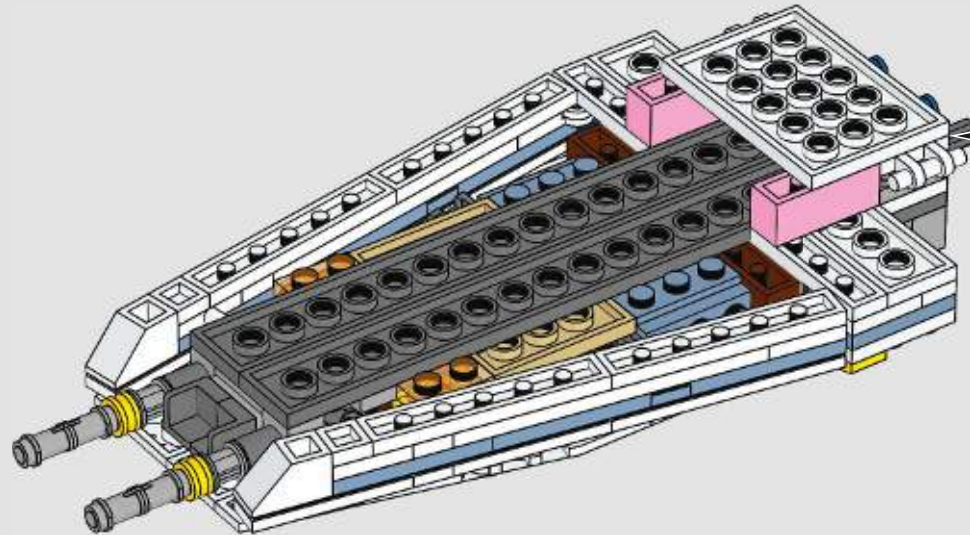
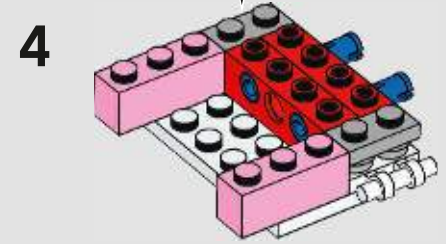
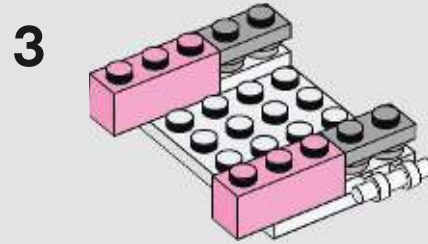
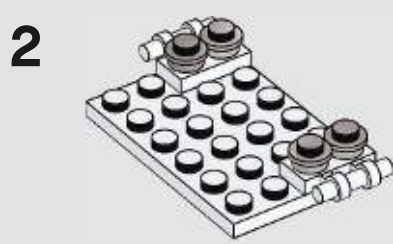
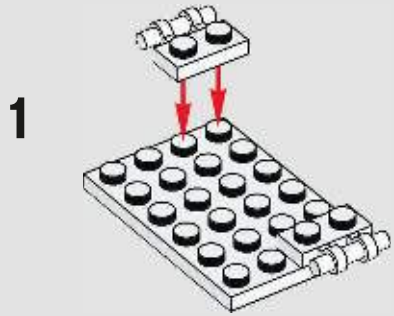
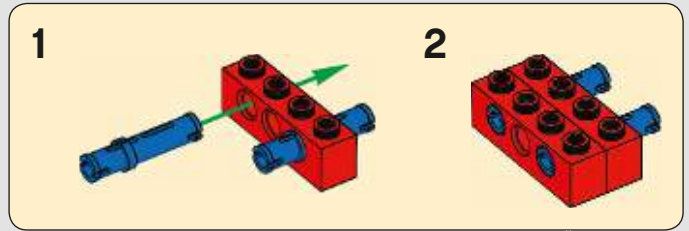

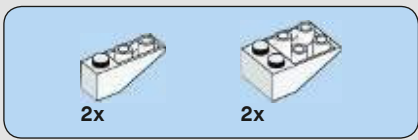

179

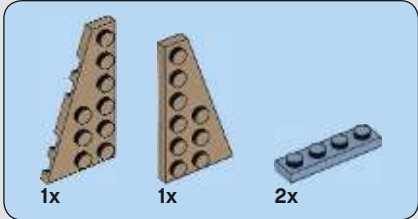
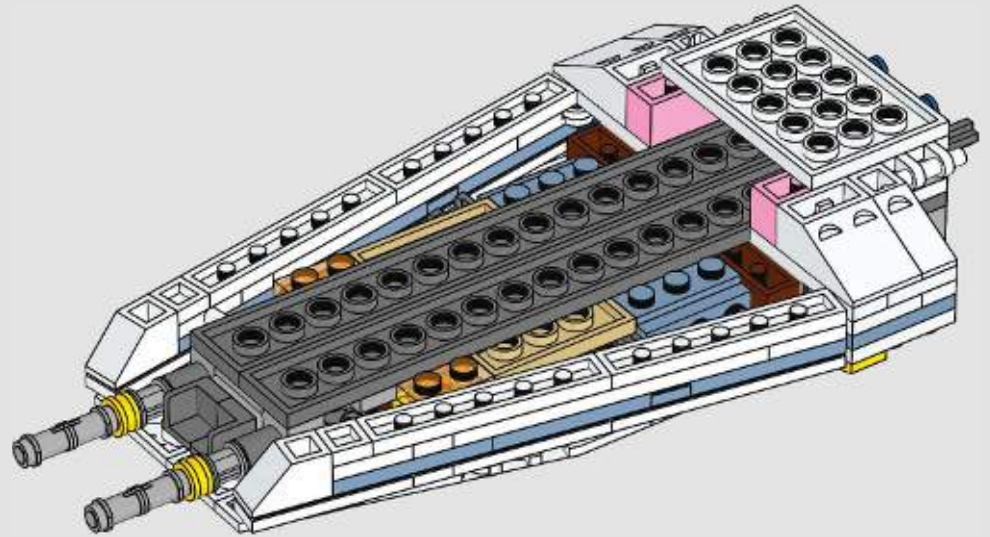

180

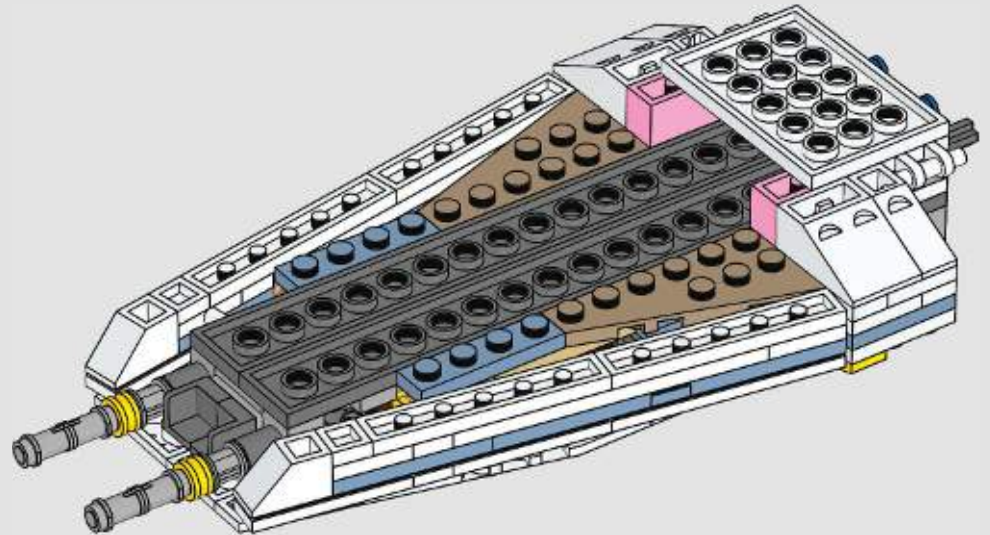

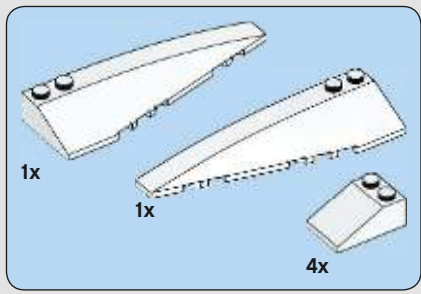

181

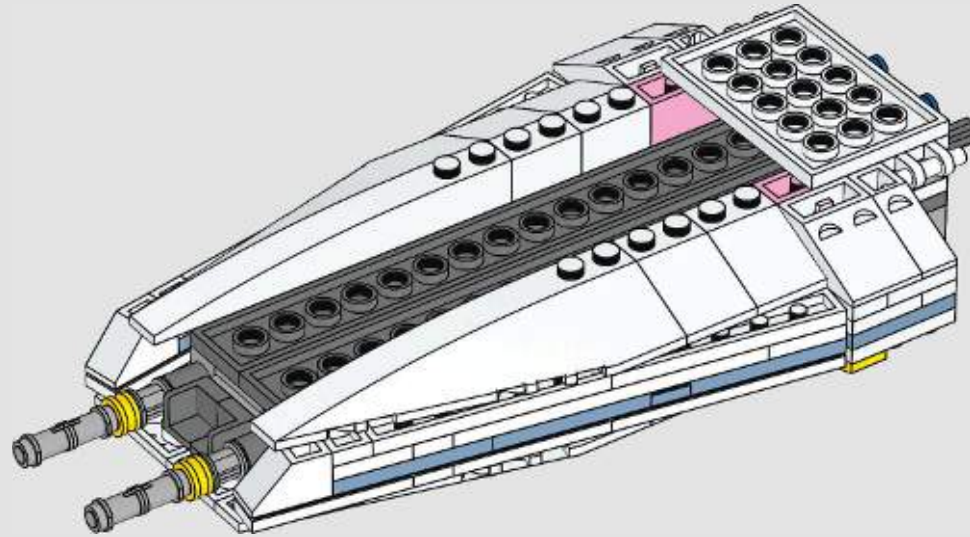

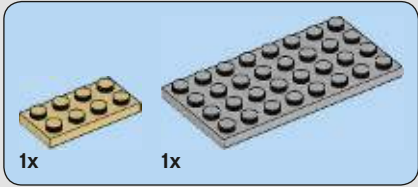
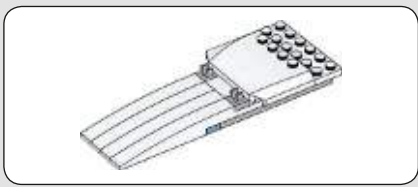

182

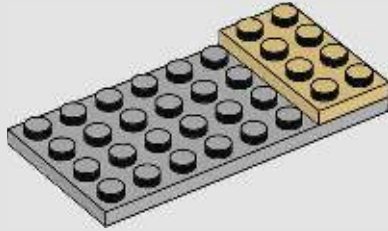

183

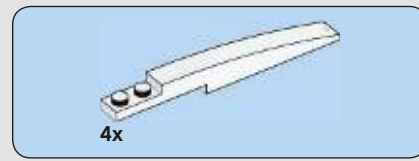
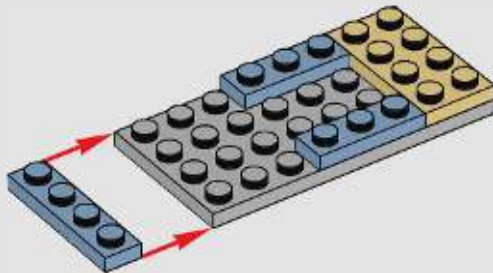

184

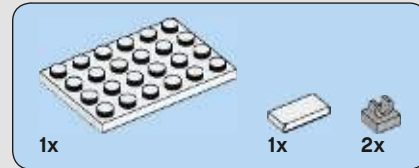
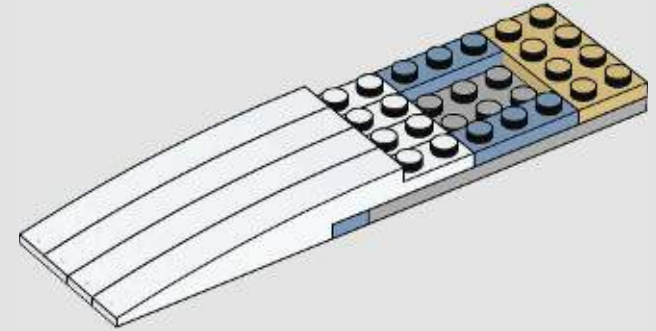

185

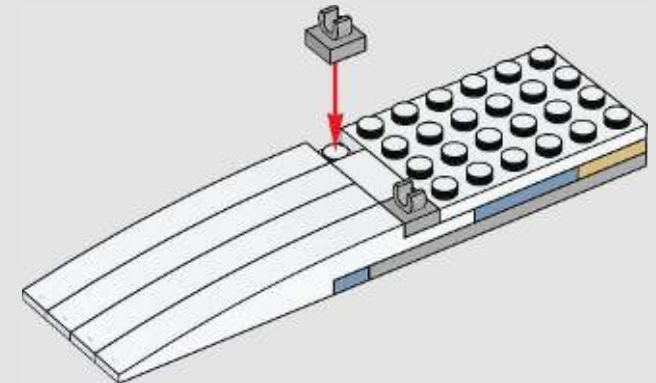

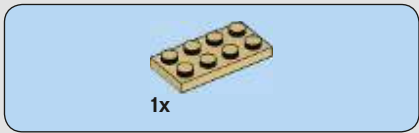

186

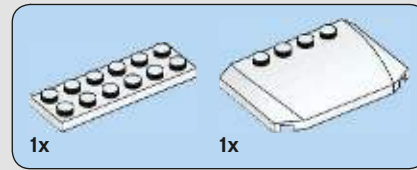
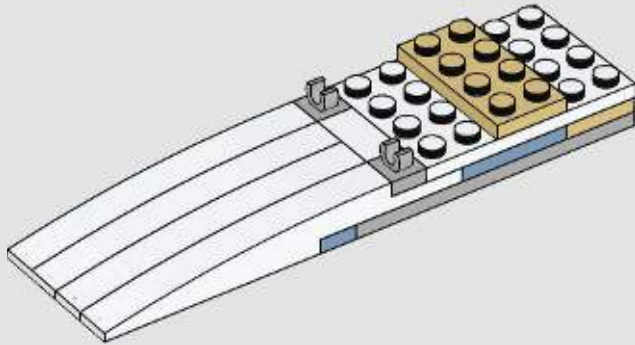

187

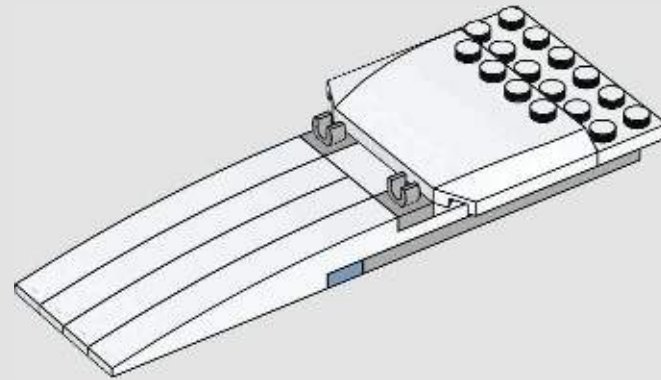

188

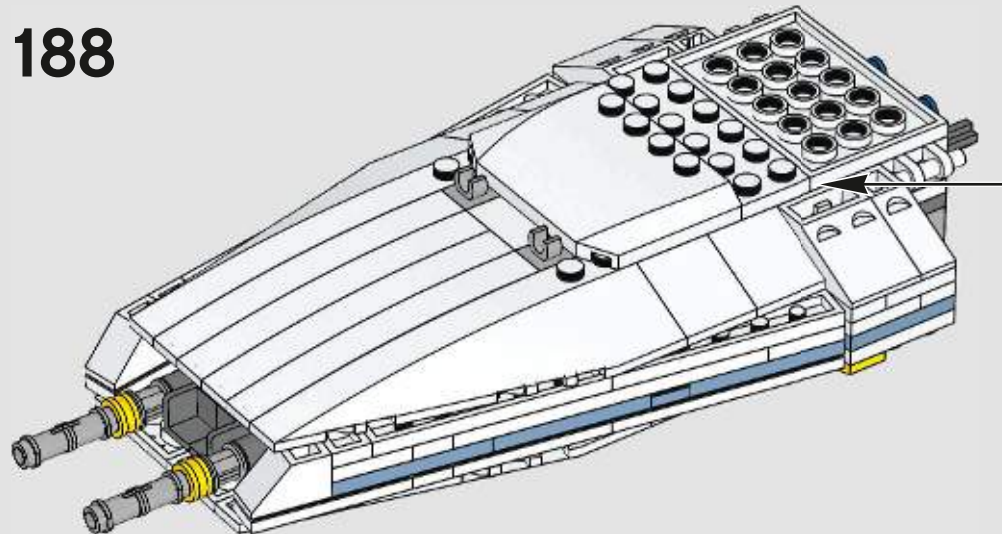

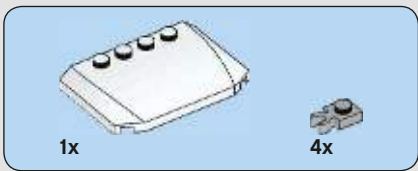

189

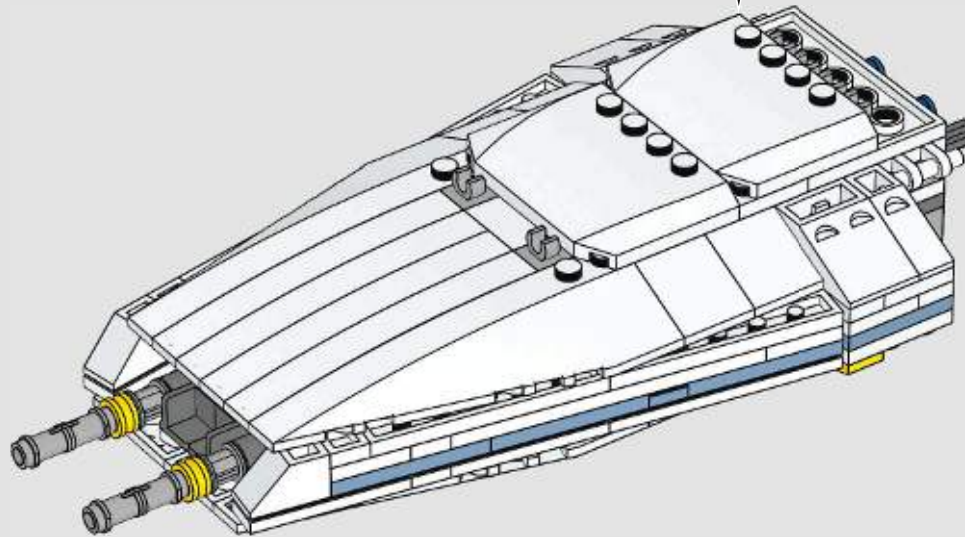
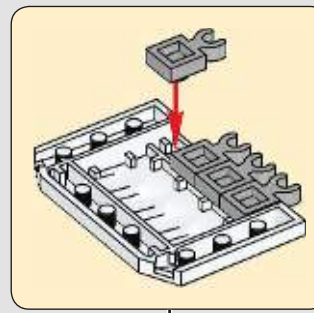

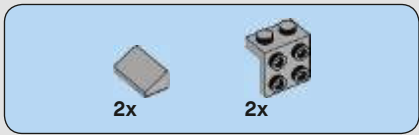

190

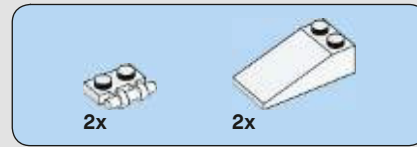
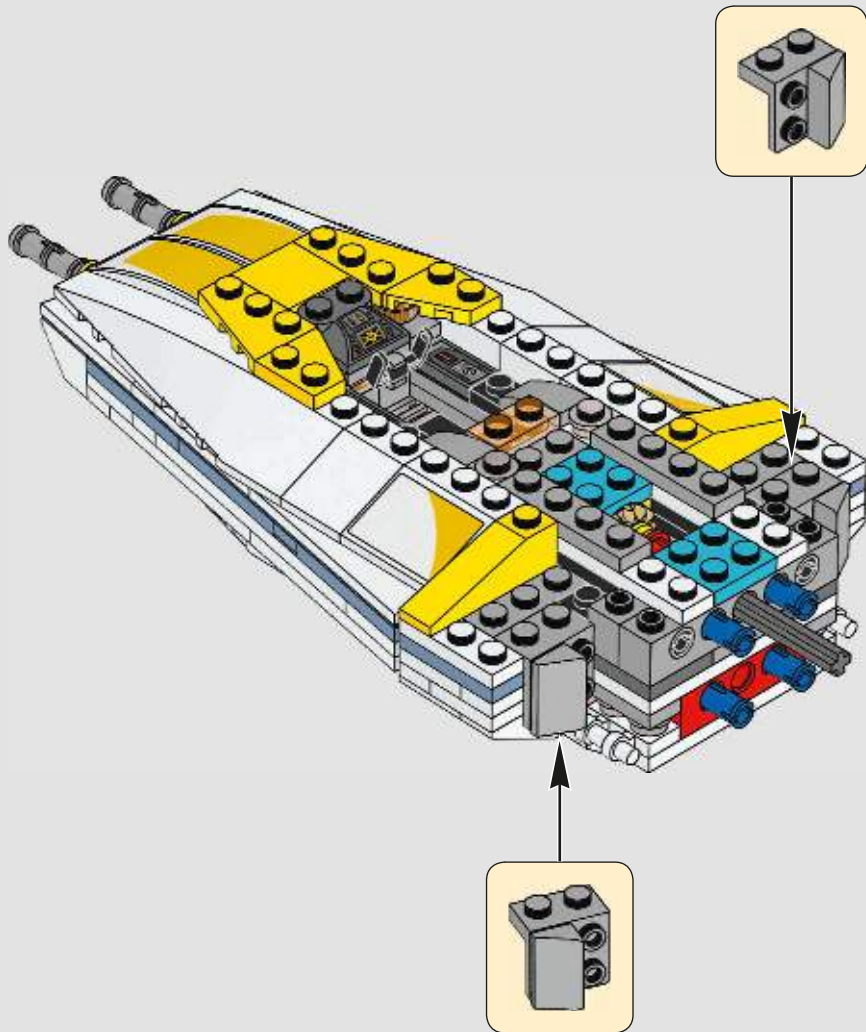

191

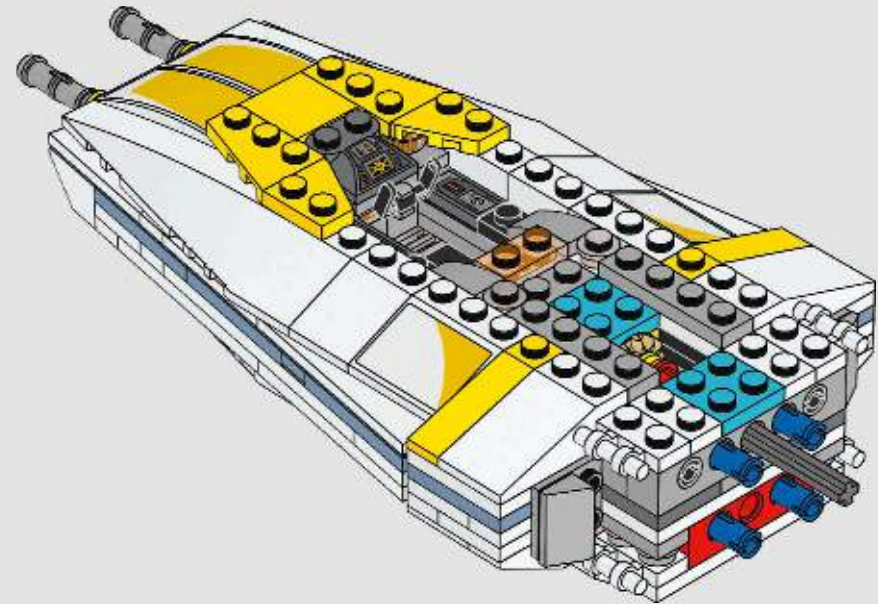



192

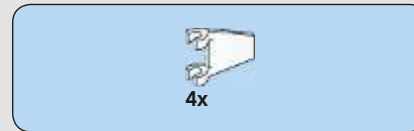
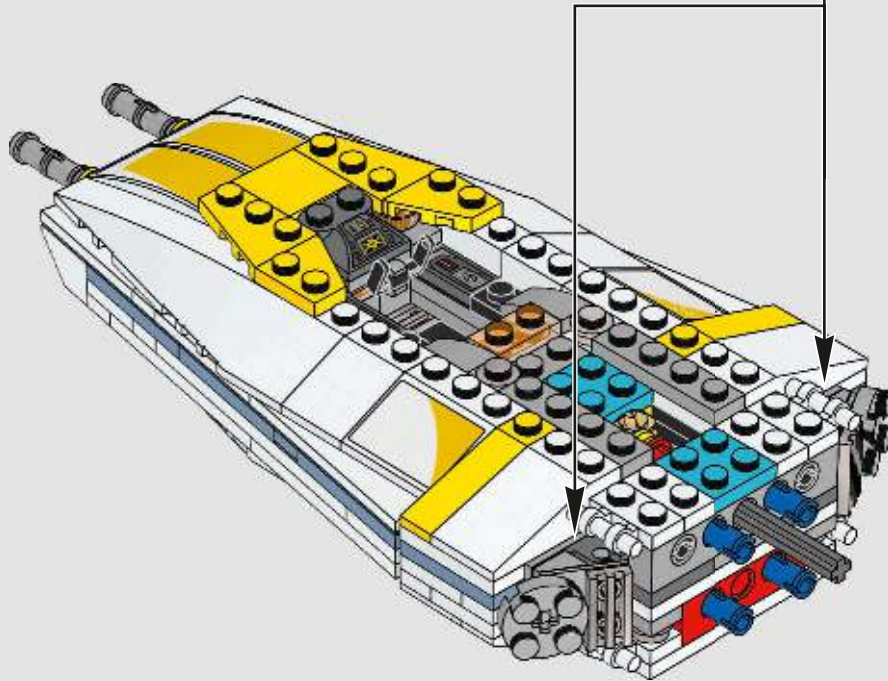
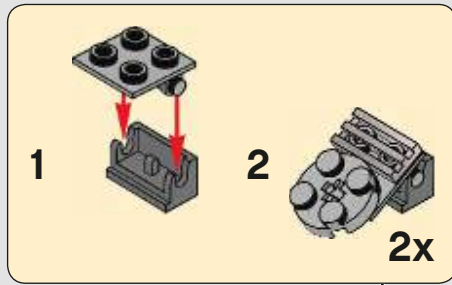

193

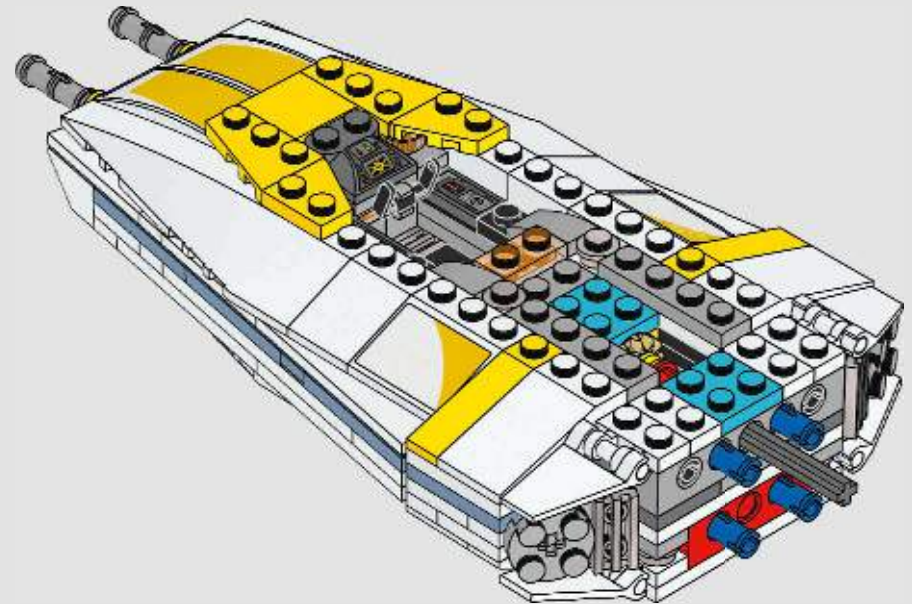

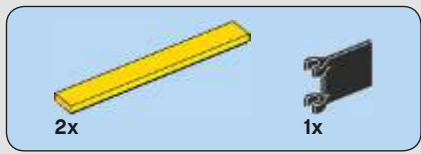

194

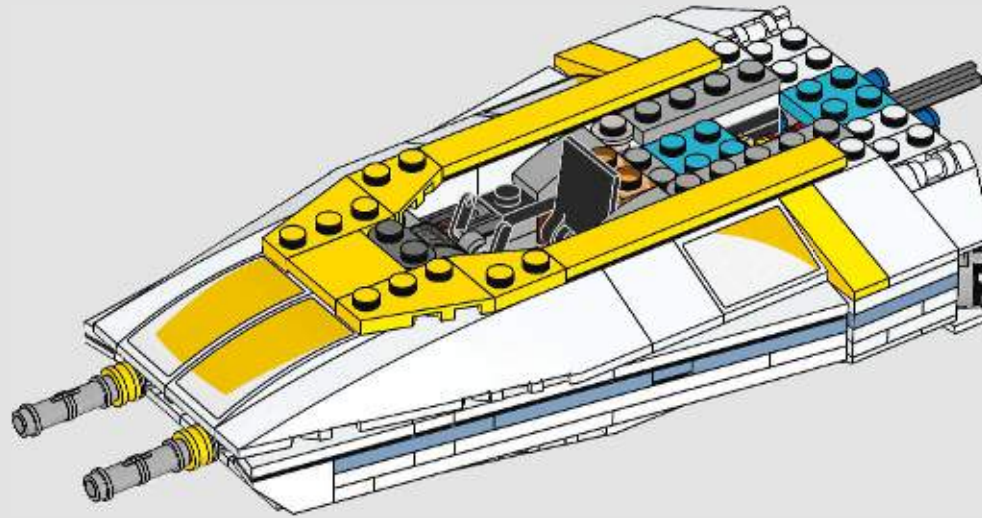

195

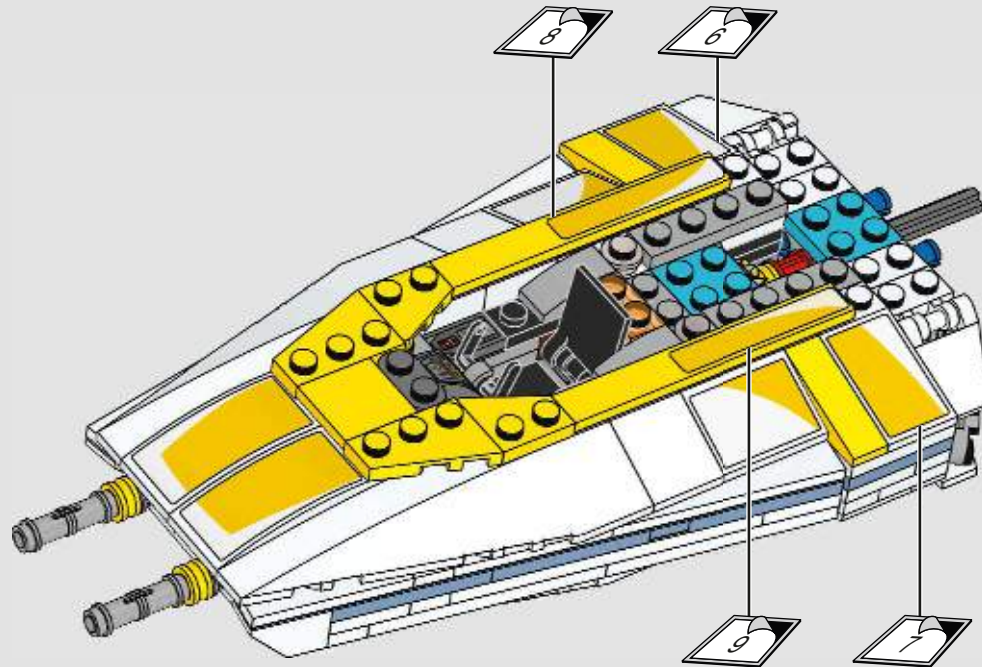

196

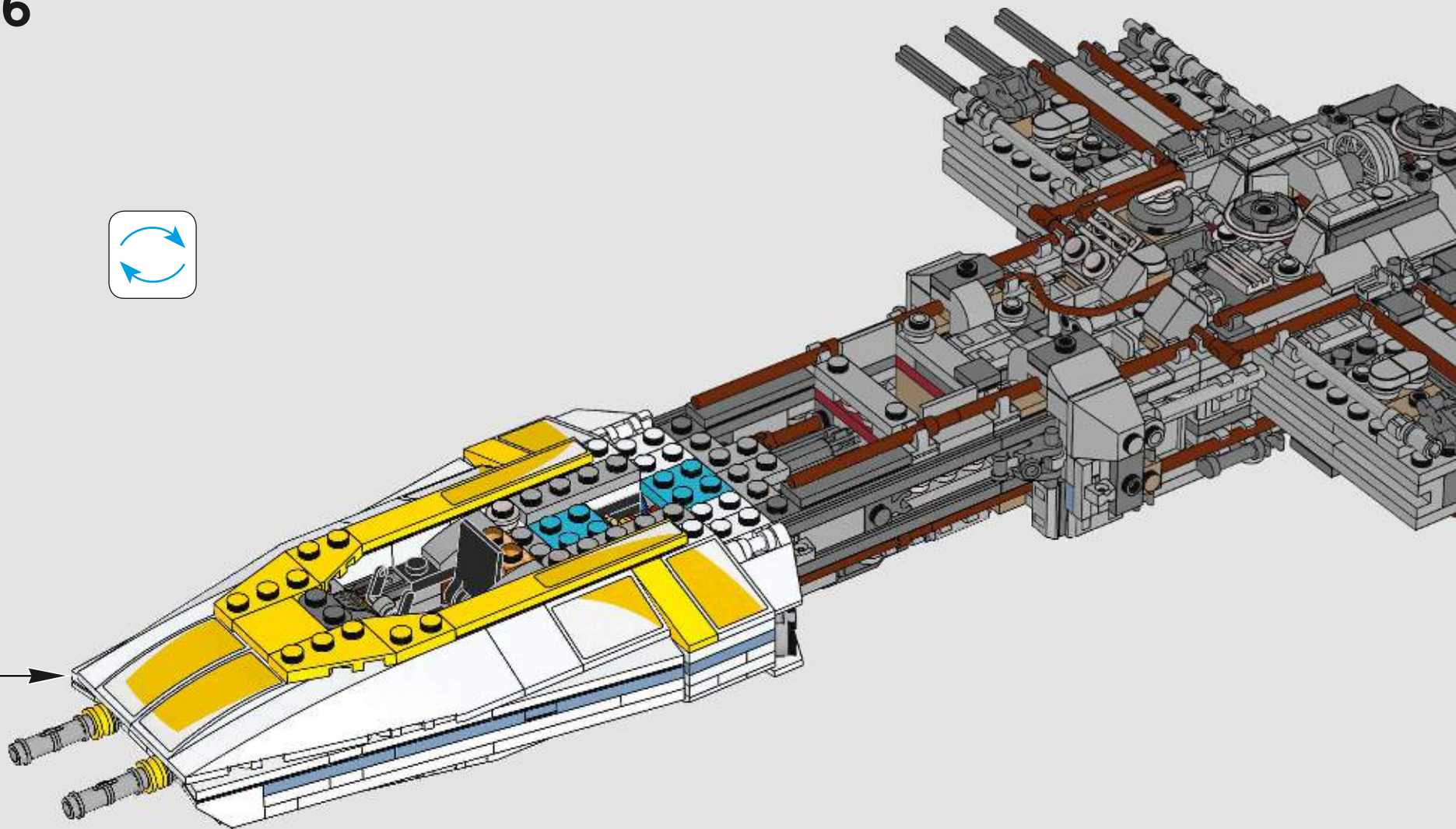
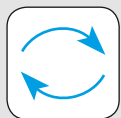



197

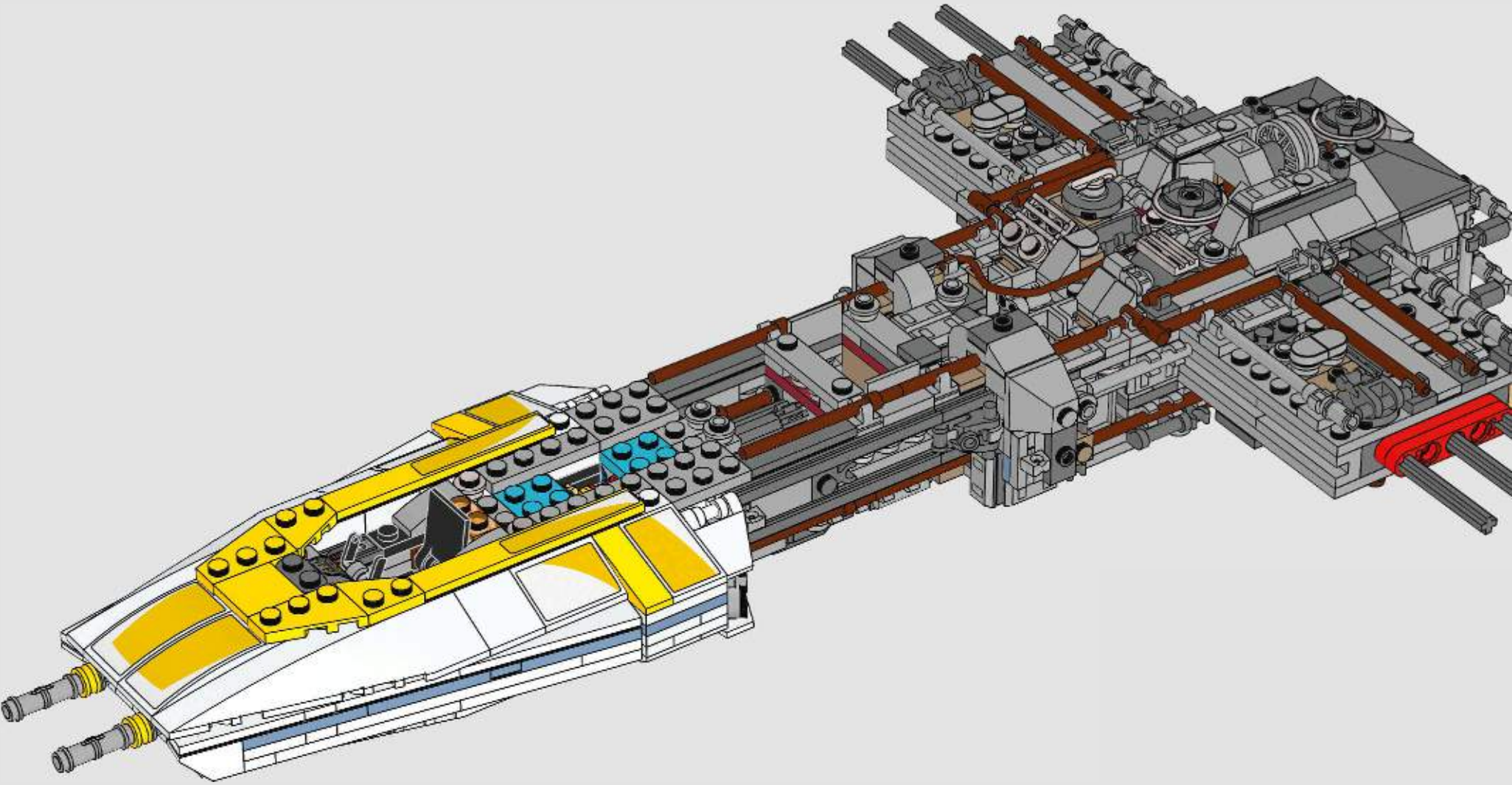



198

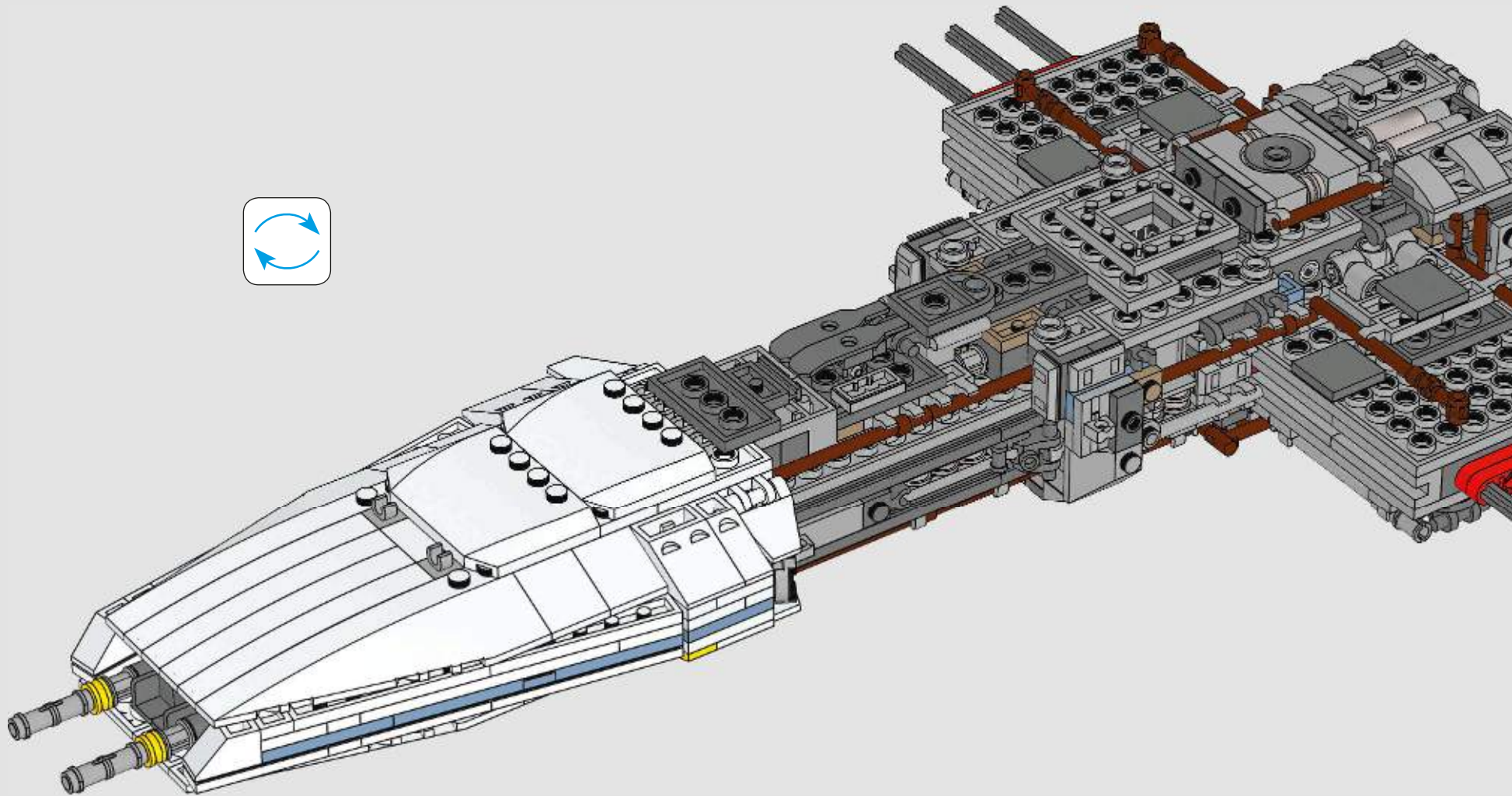



199

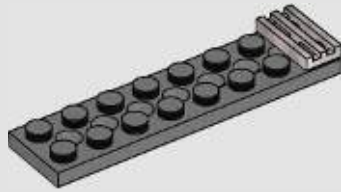

200

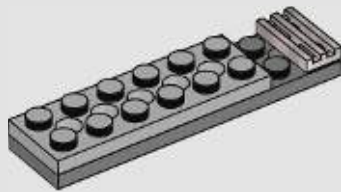

201

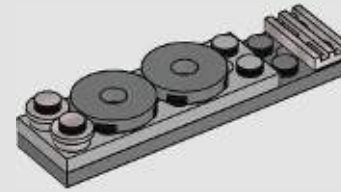

202

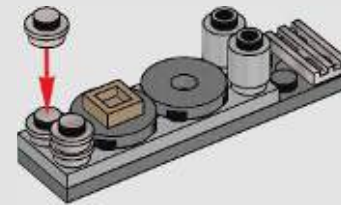

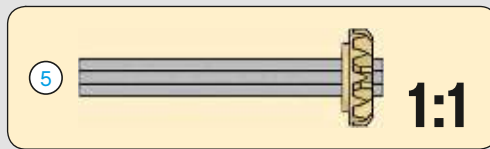
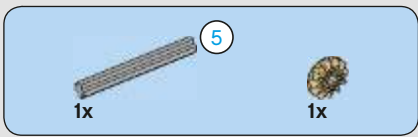

203

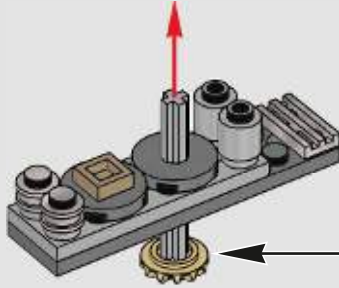

204

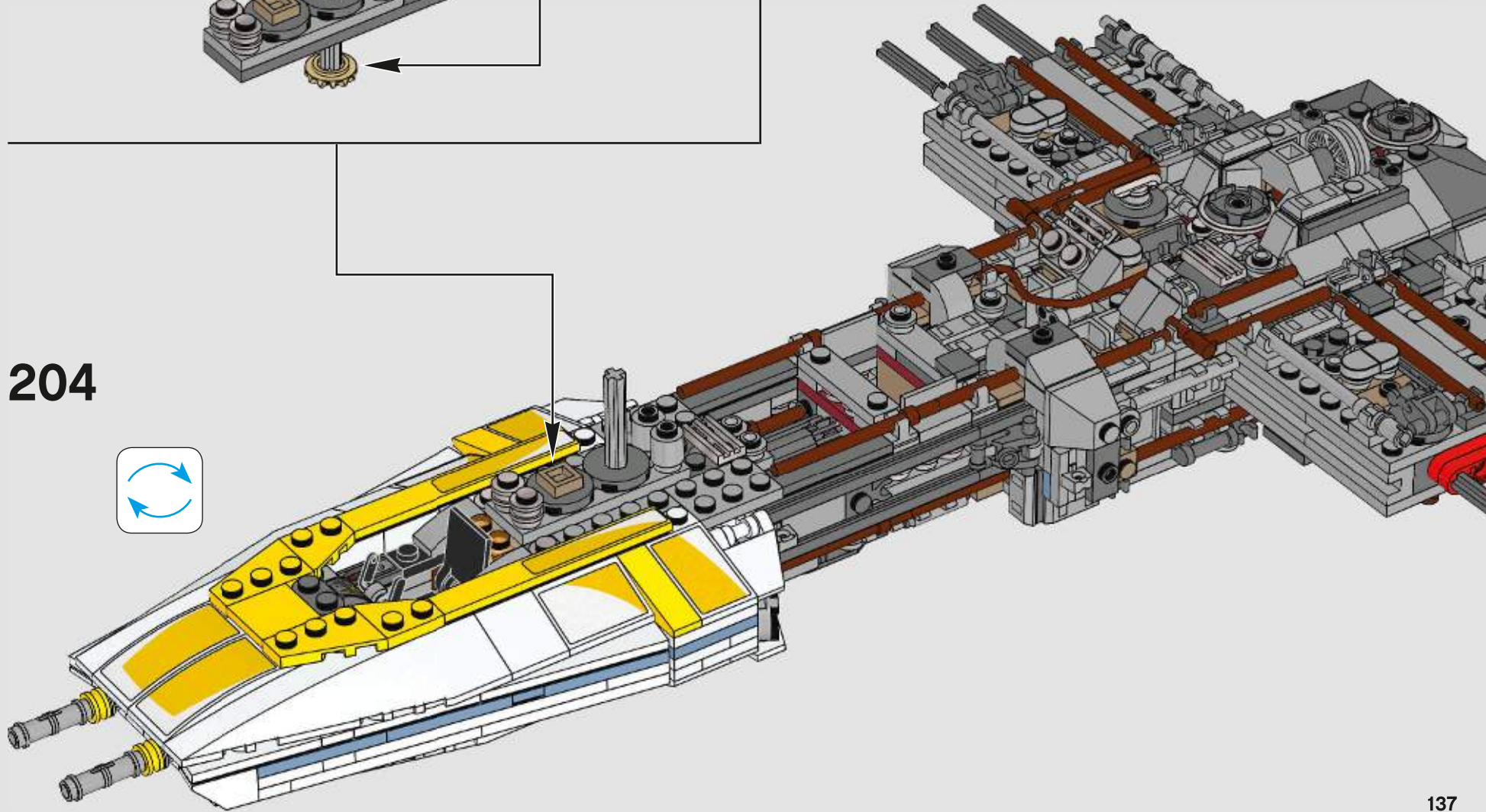
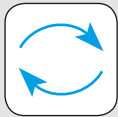



205

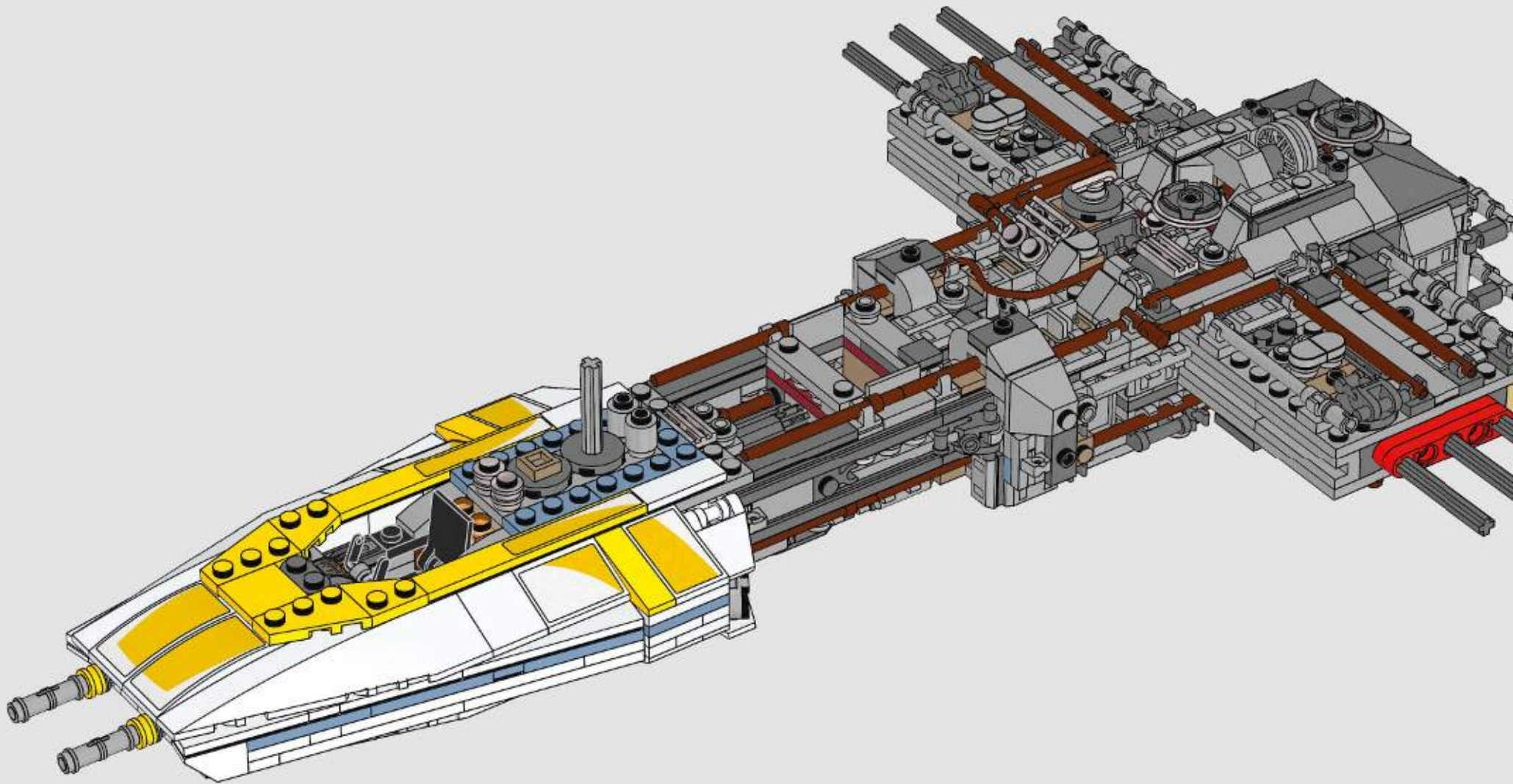

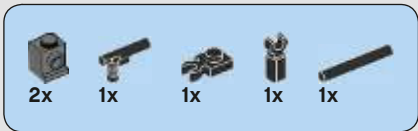

206

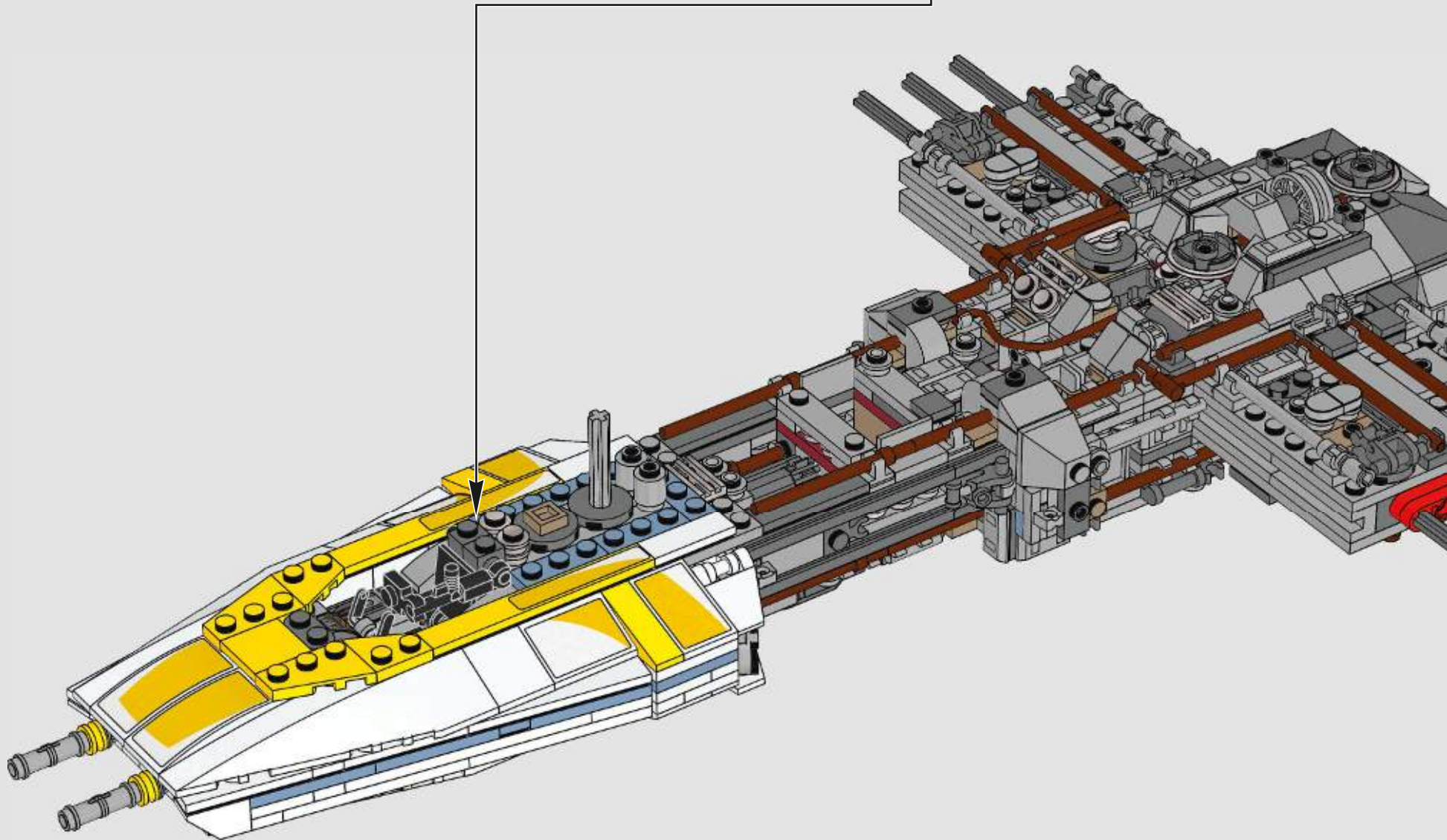
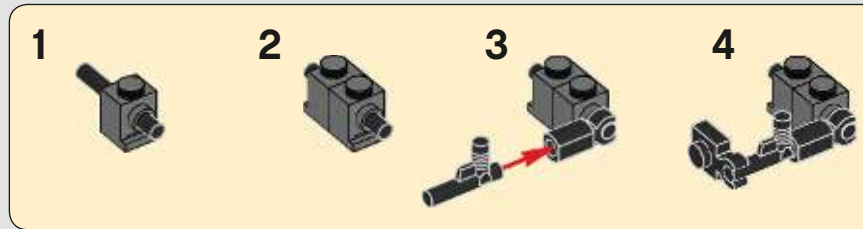



207

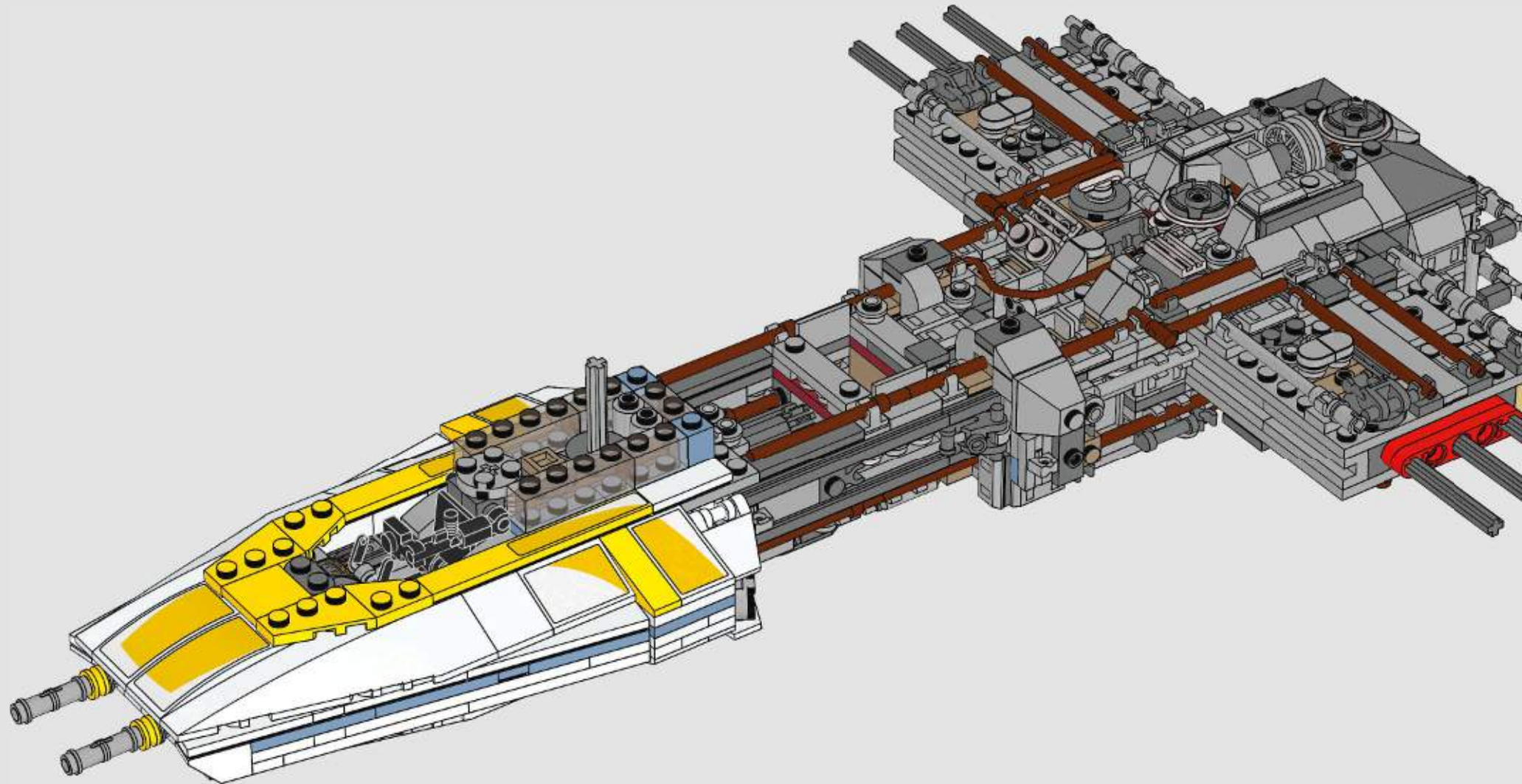

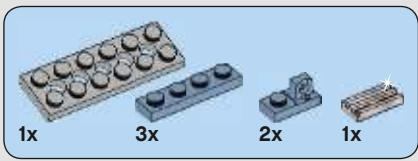

208

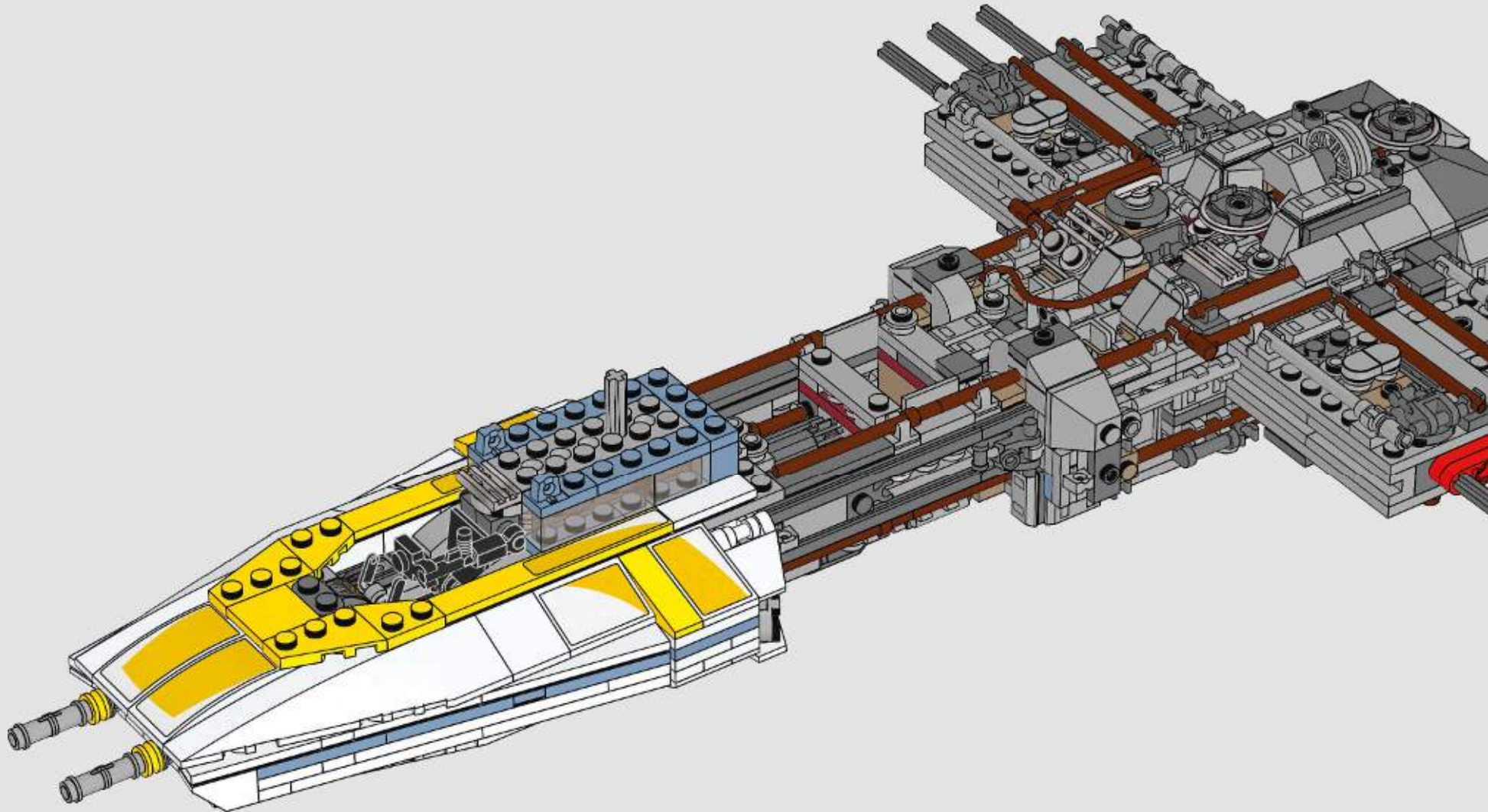

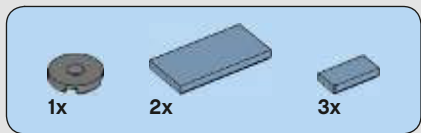

209

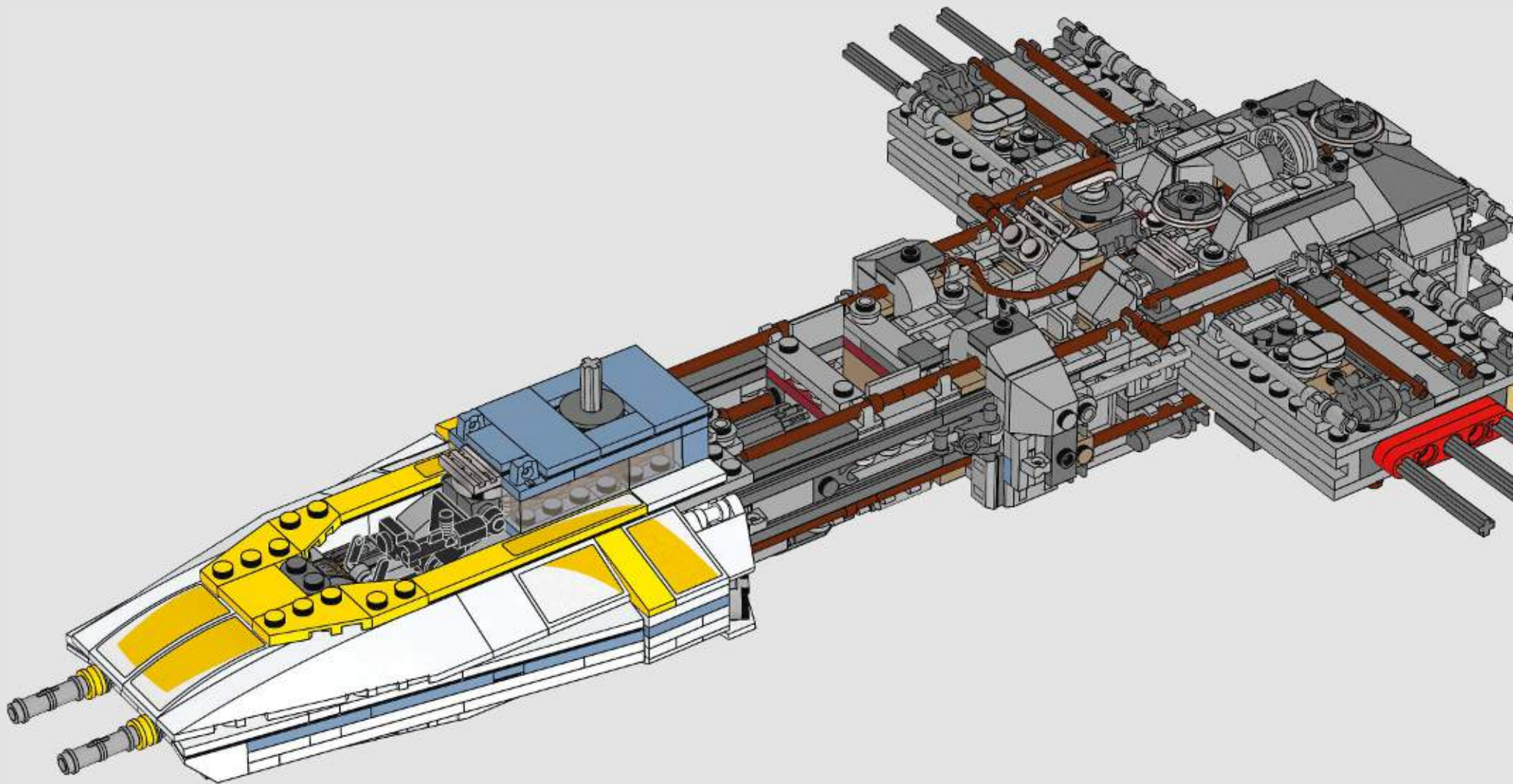

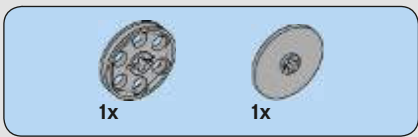

210

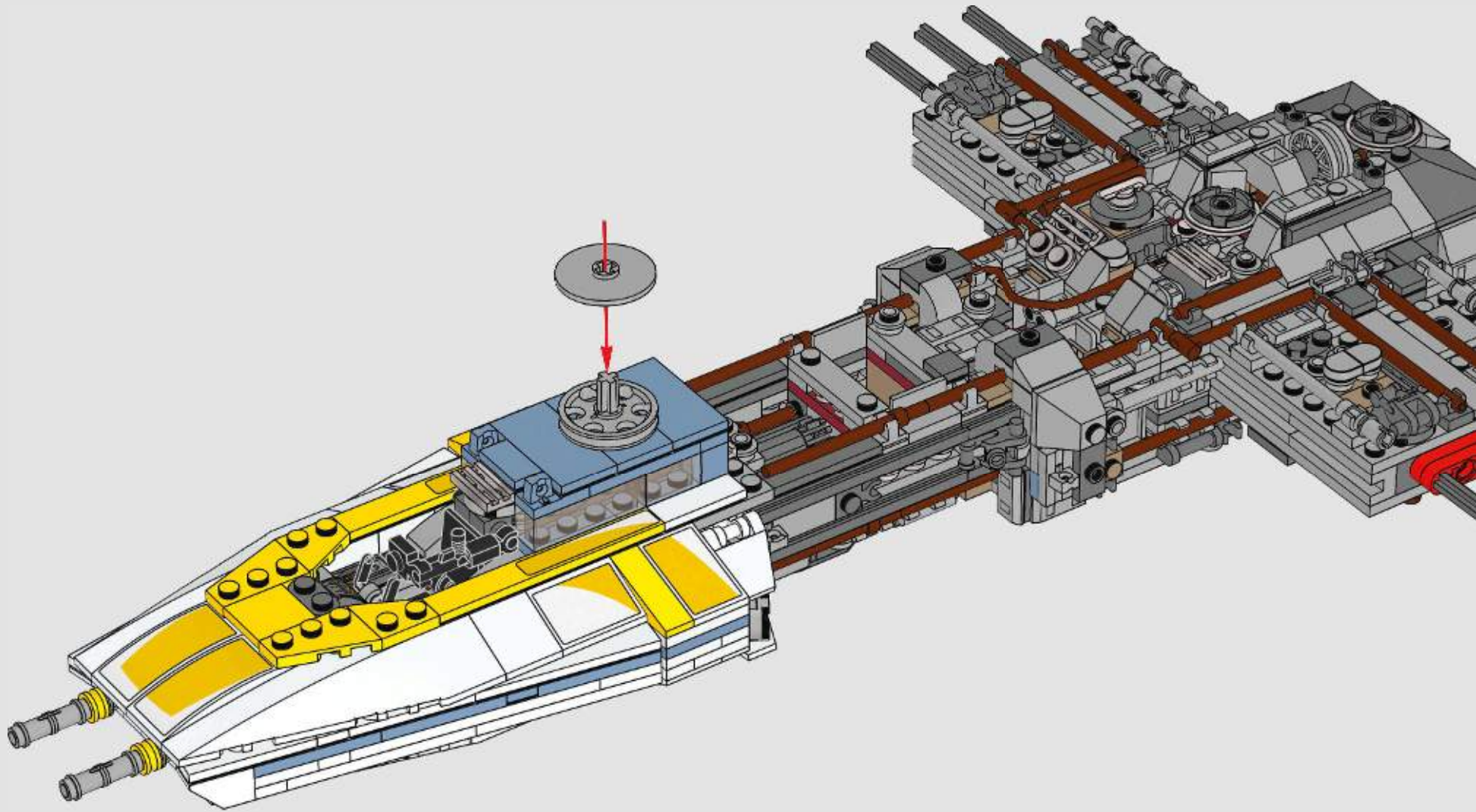

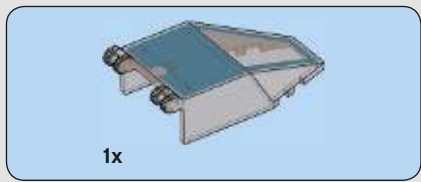

211

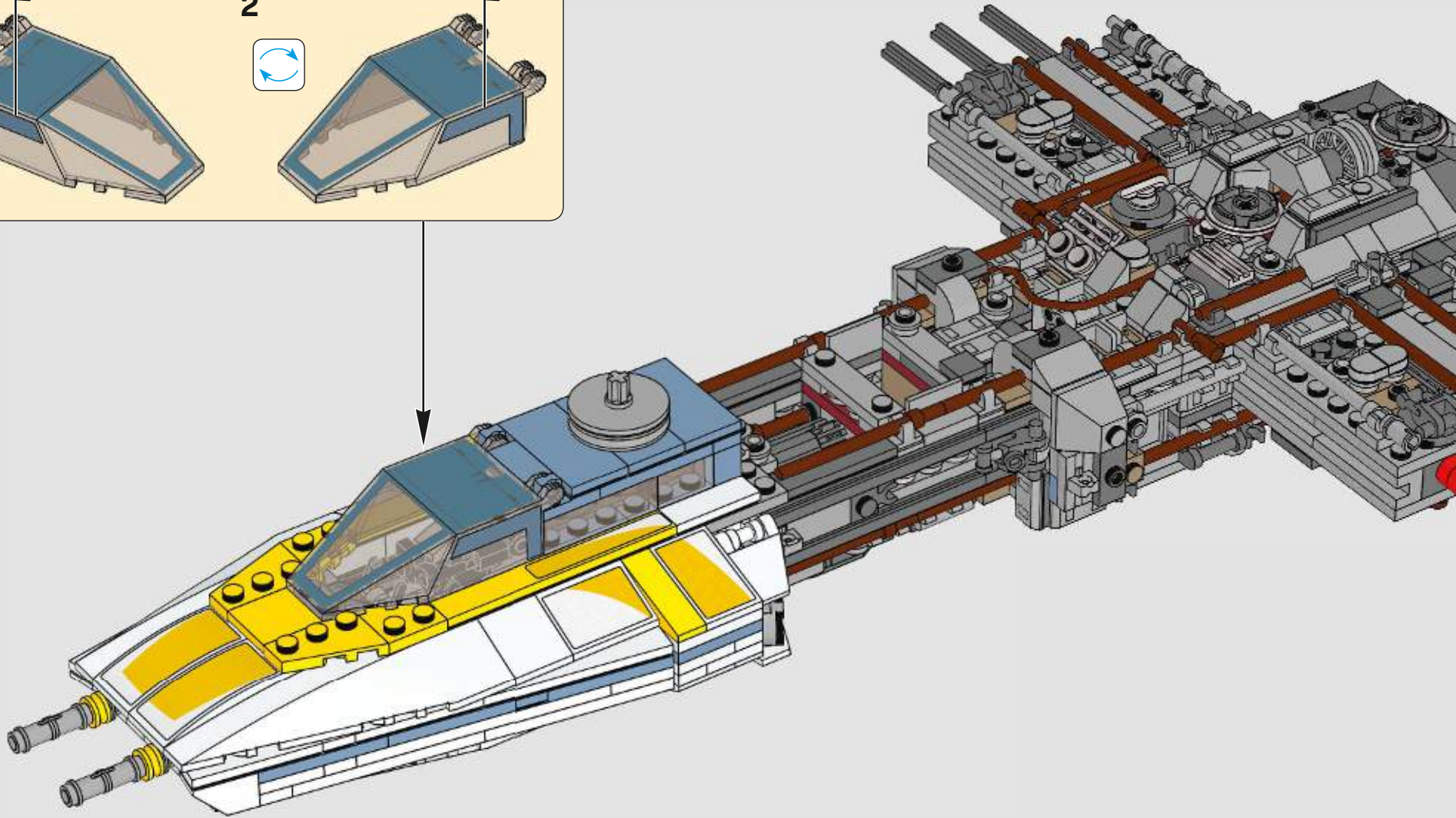
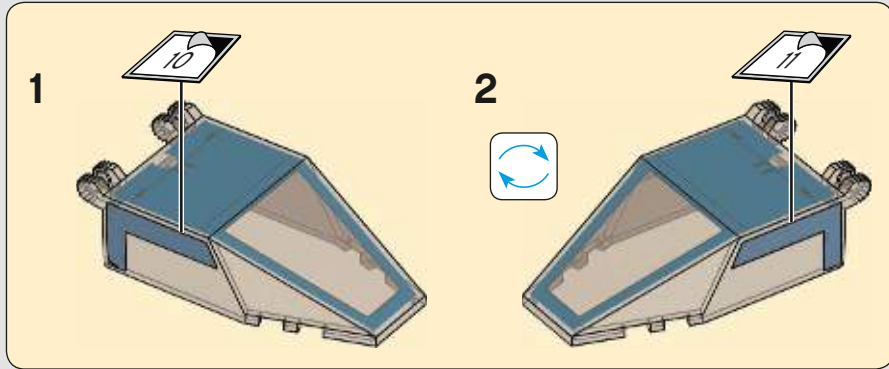

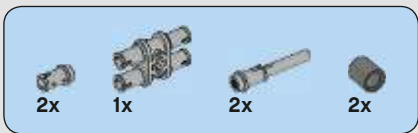

212

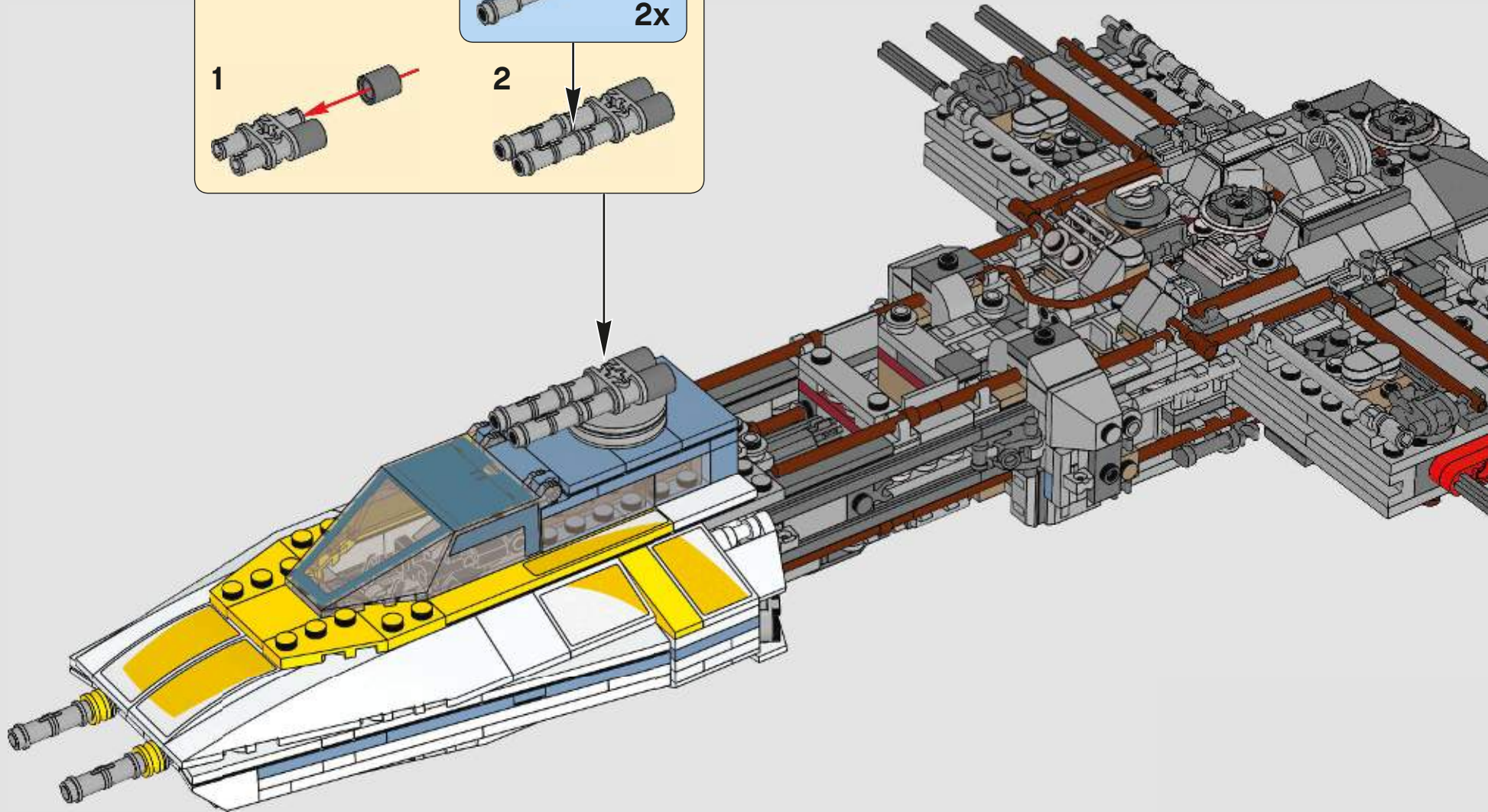
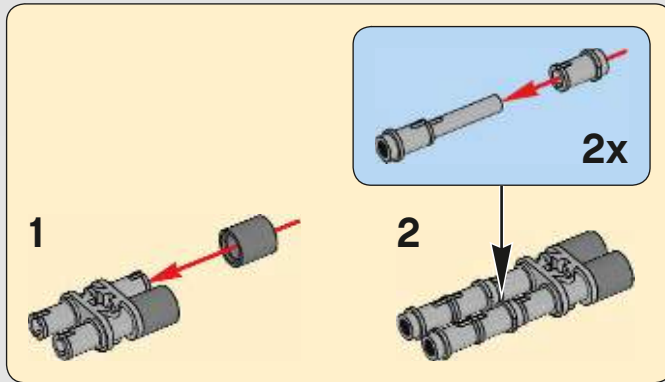

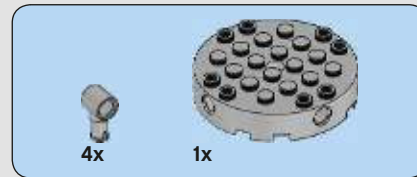
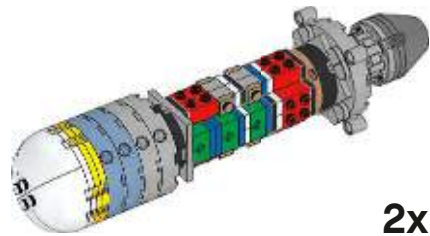
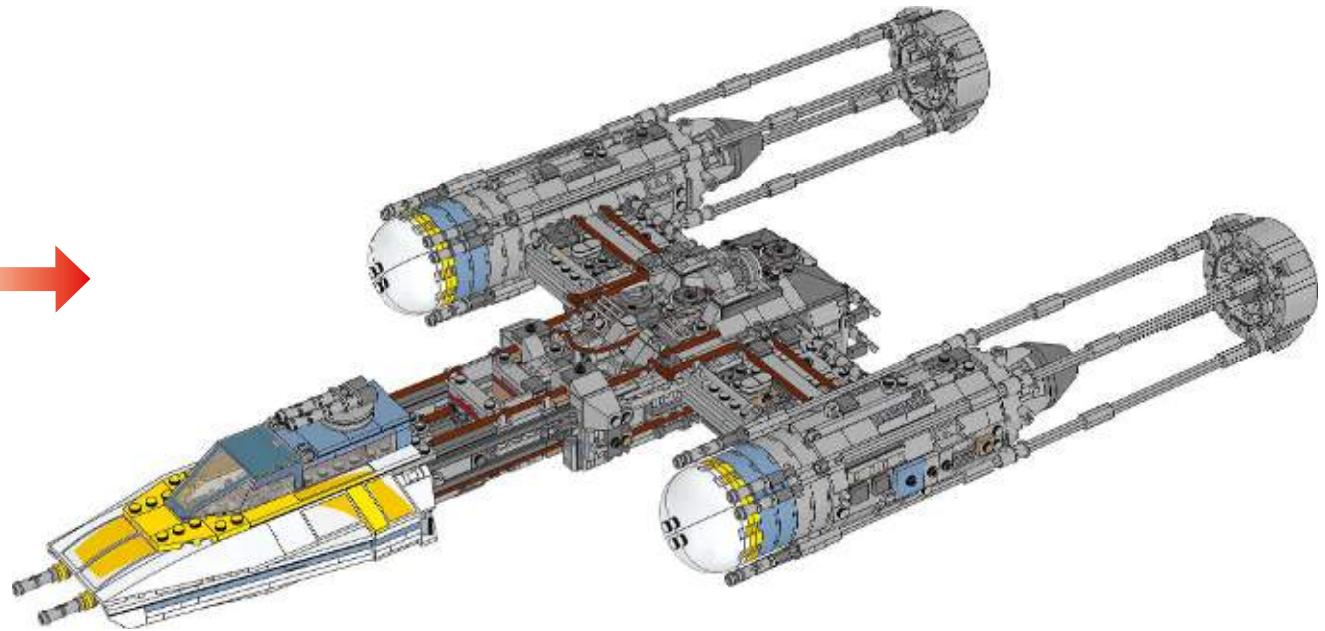

213

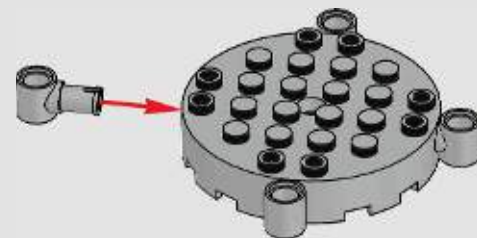

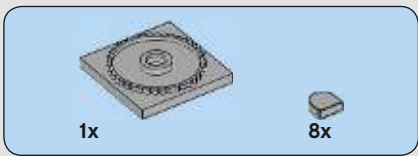

214

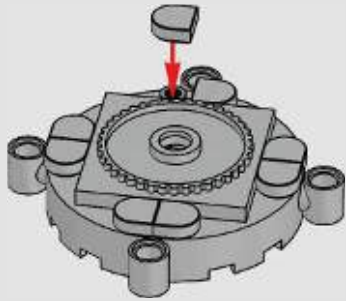

215

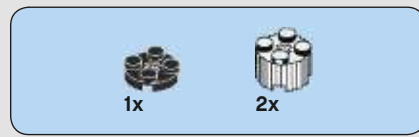
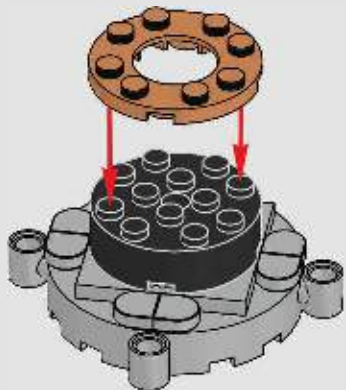

216

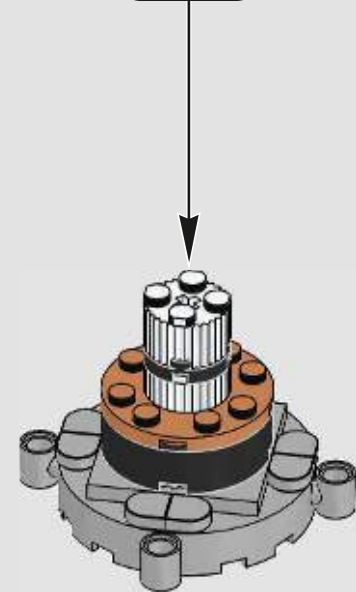
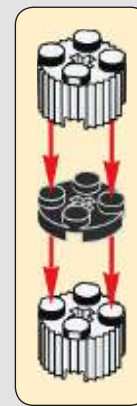



217

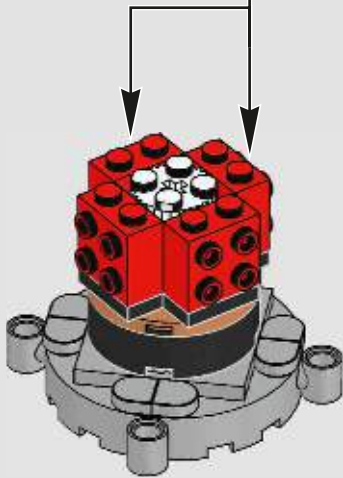

218

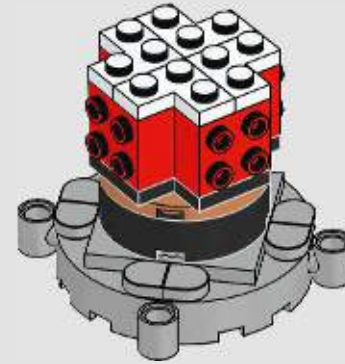

219

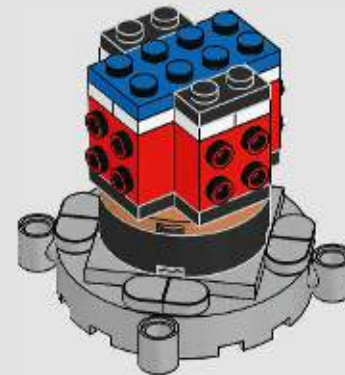



220

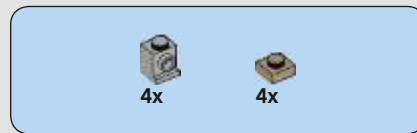
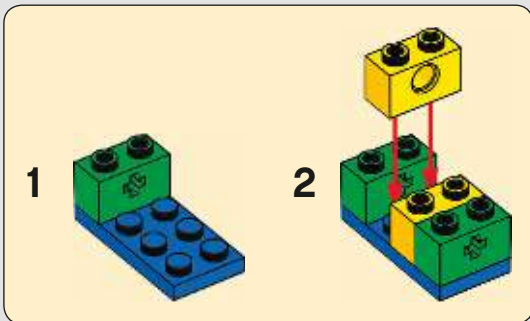

221

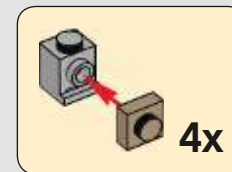

222

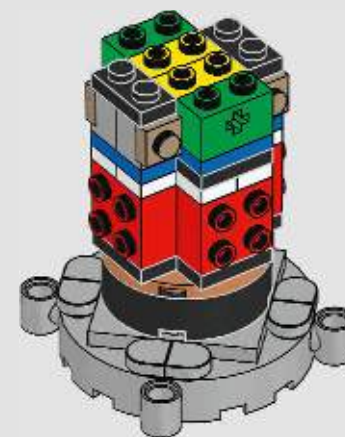



4x

223



2x



2x



2x

224

1

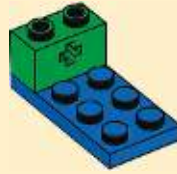

2

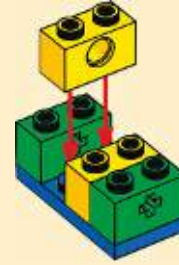

3

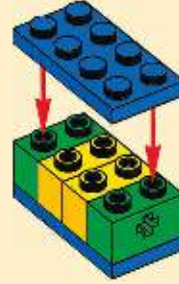



225

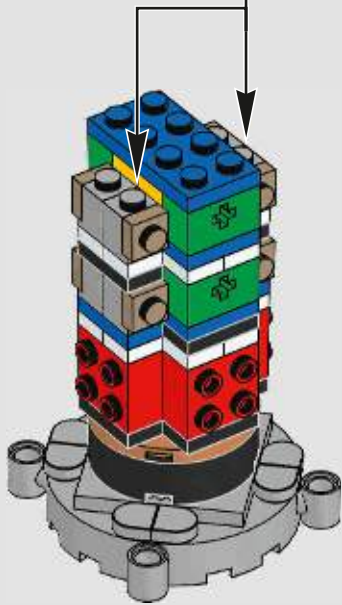
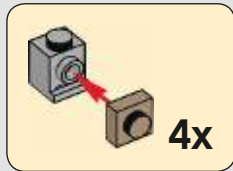

226

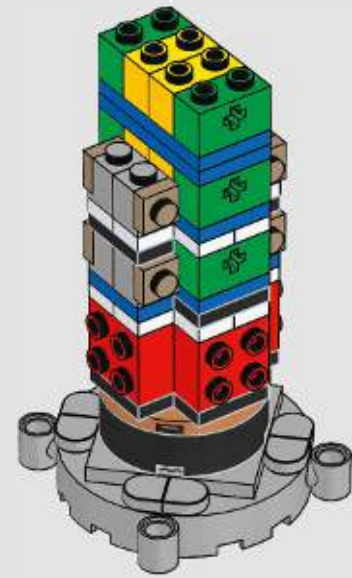
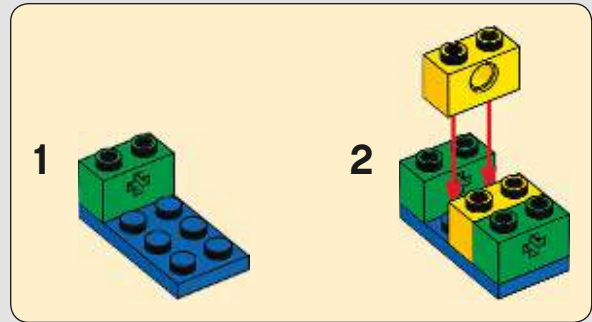



227

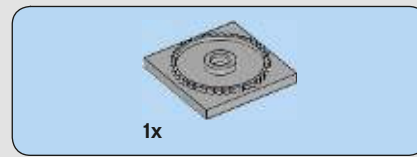
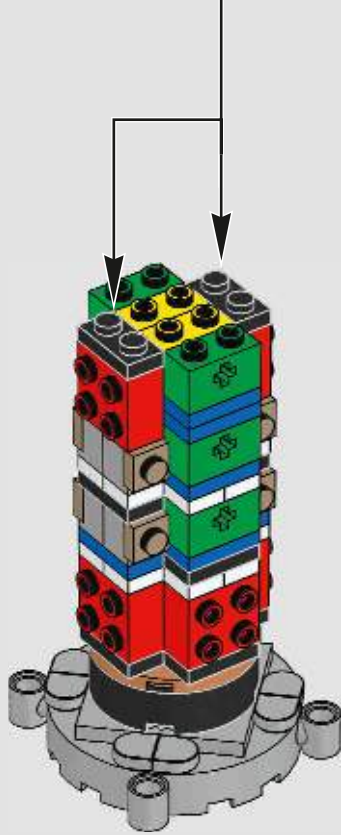
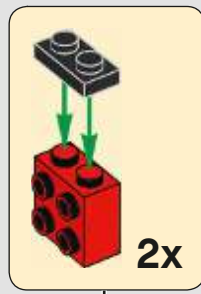

228

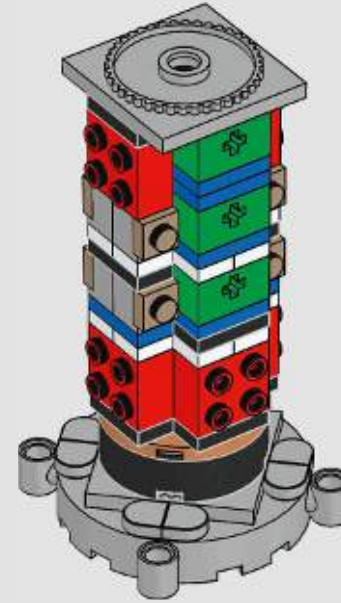

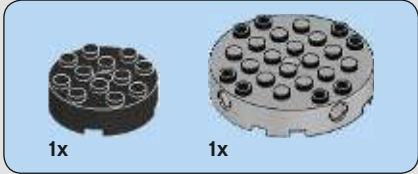
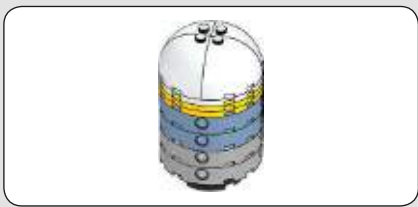

229

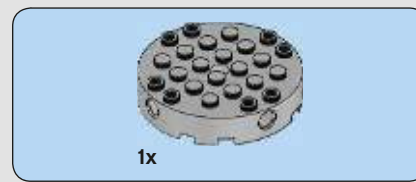

230

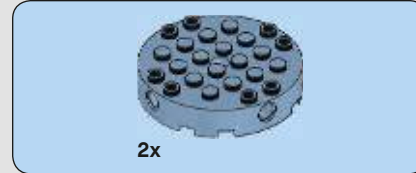

231

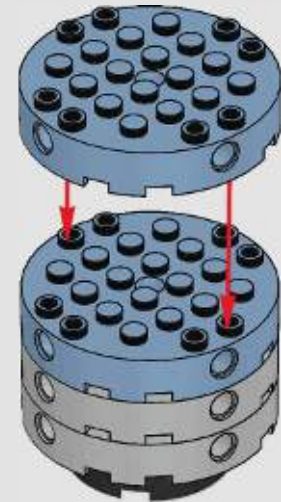

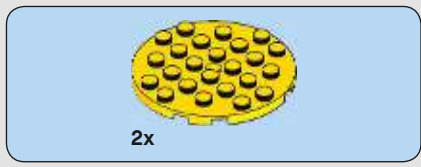

232

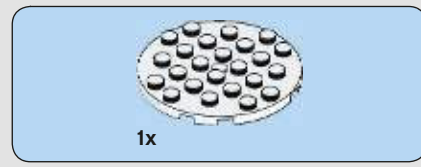
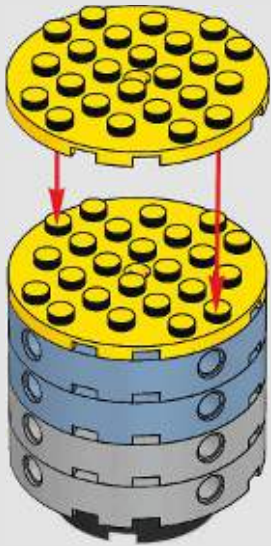

233

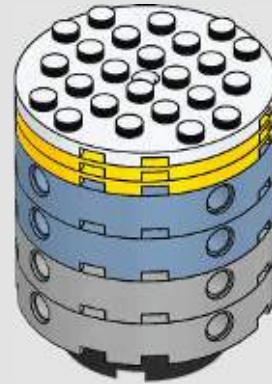



234

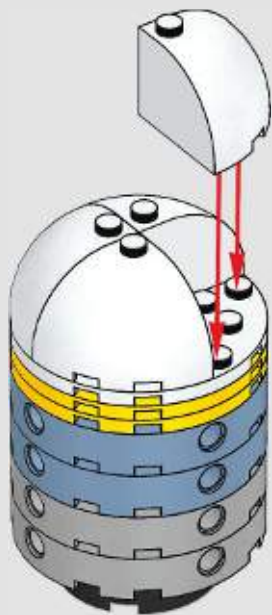

235

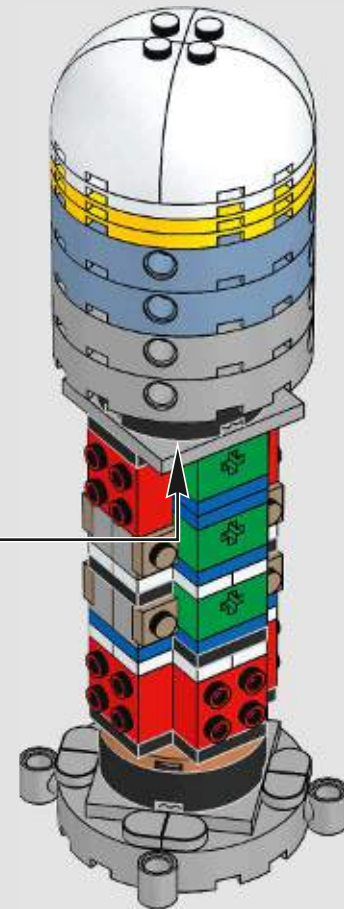

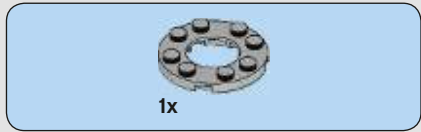

236



237

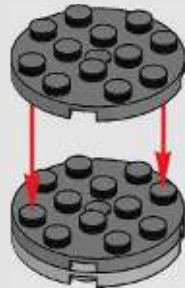

238

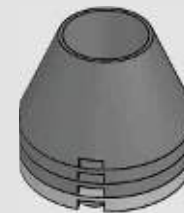

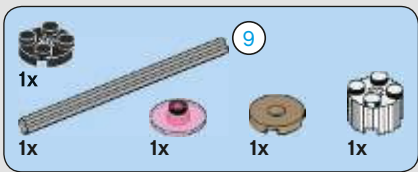

239

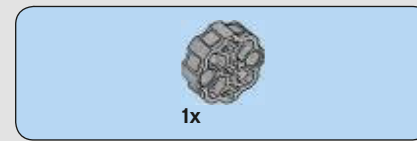
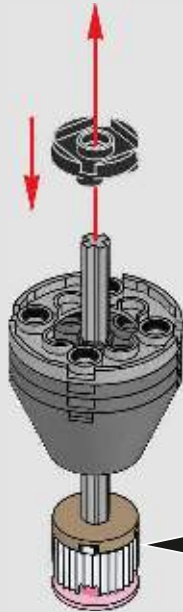
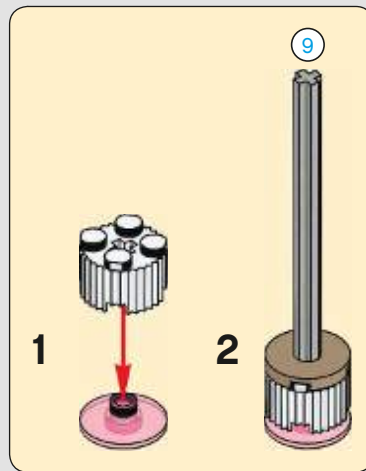

240

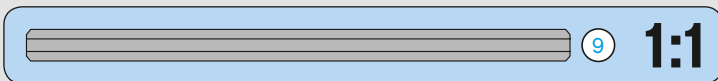
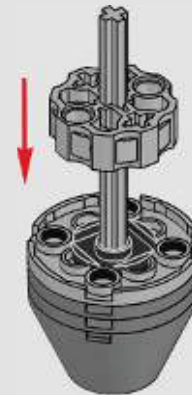

9 1:1



241

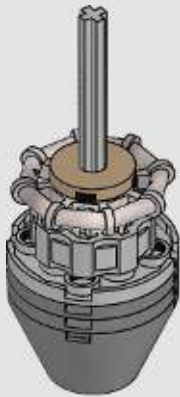
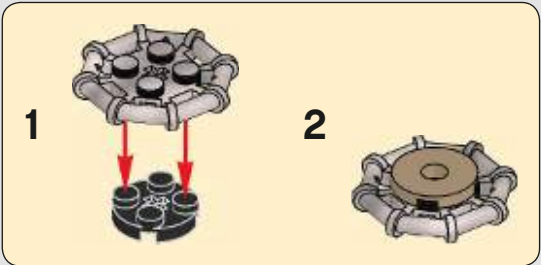

242

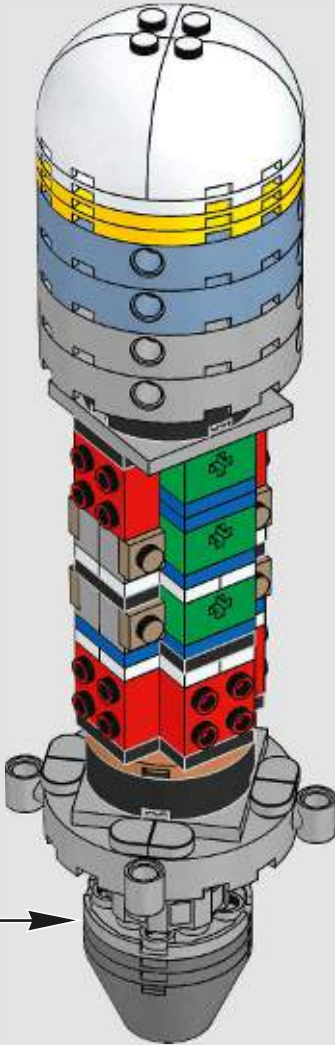

2x



10

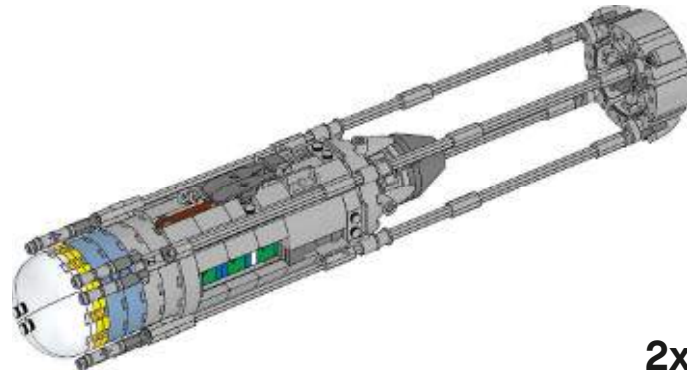

2x



4x



4x

243

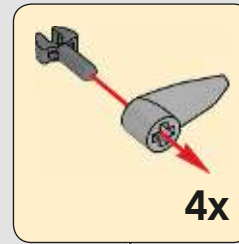

4x

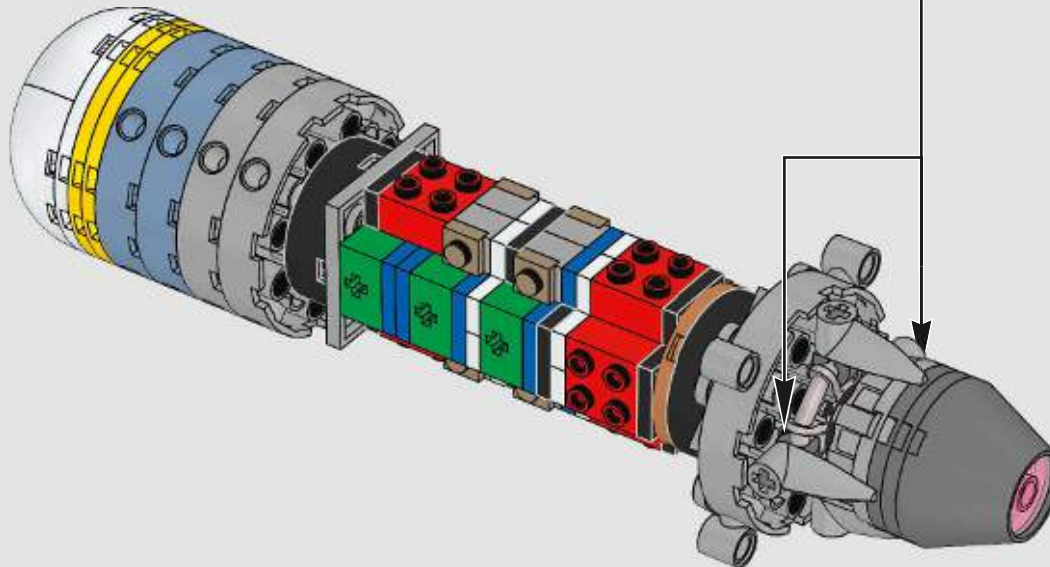

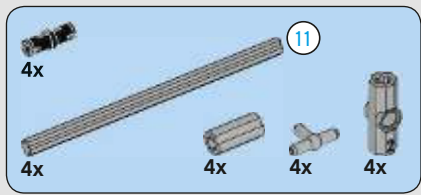

244

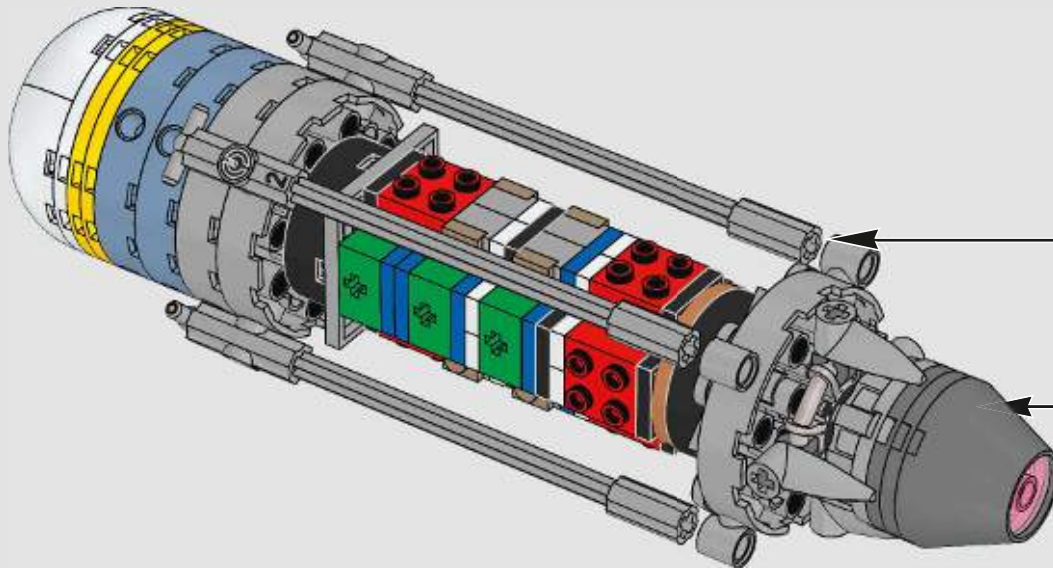
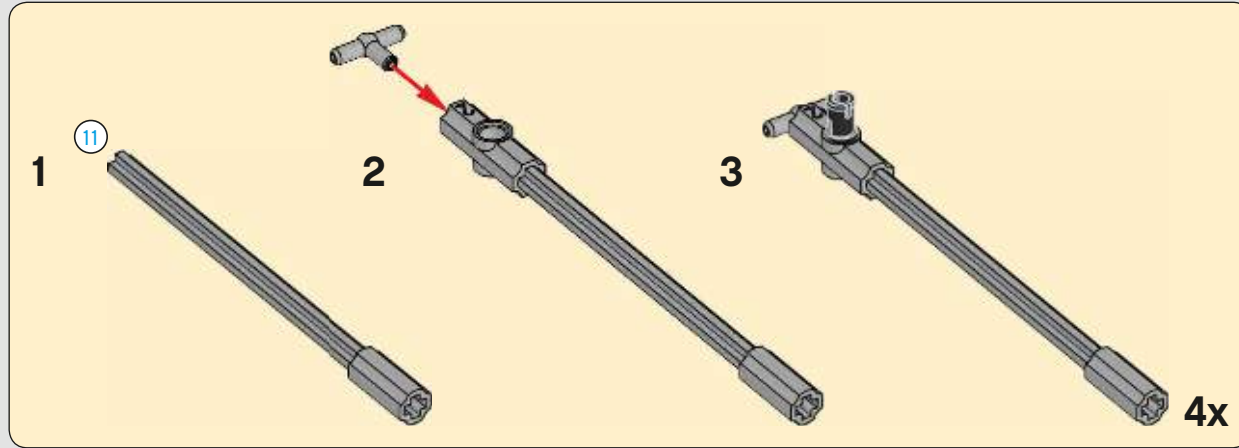
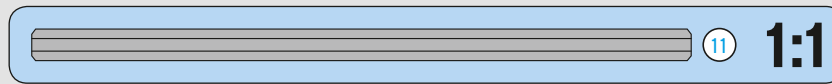

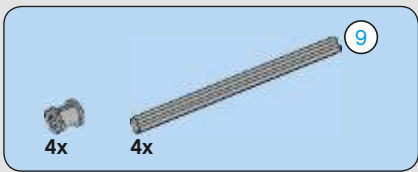

245

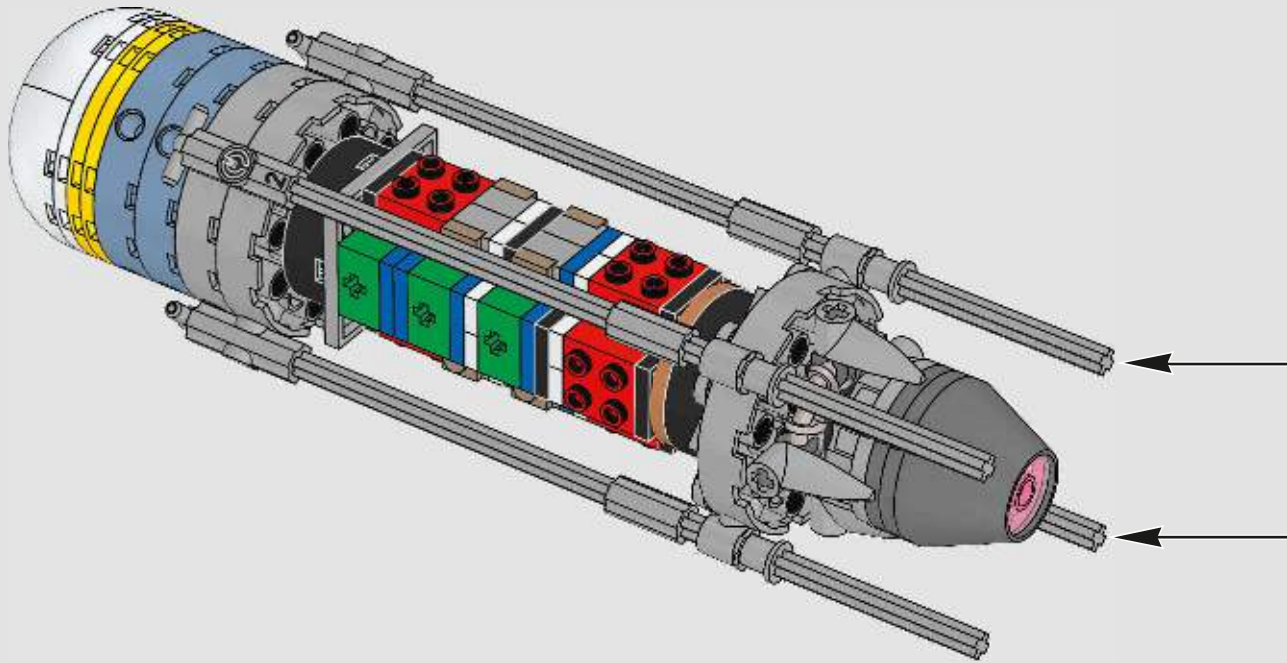
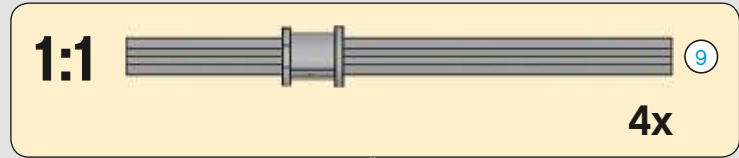

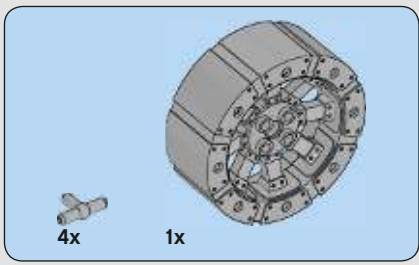

246

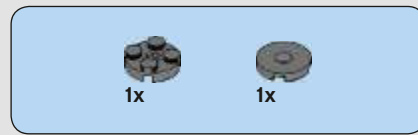
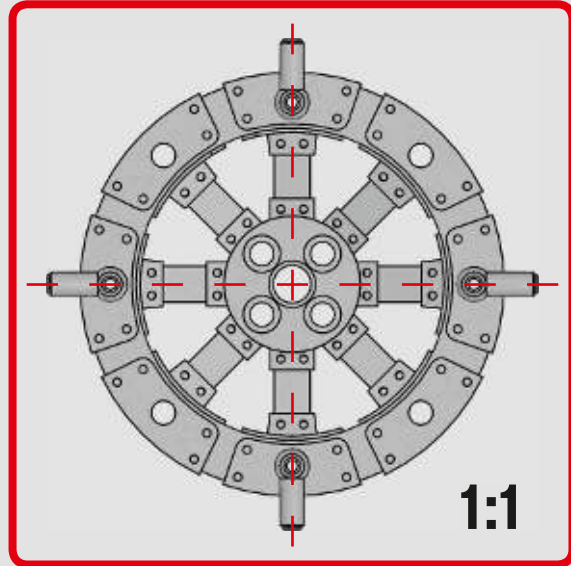
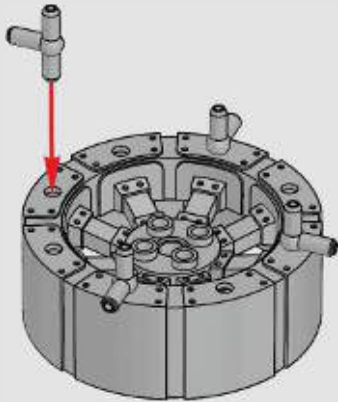

247

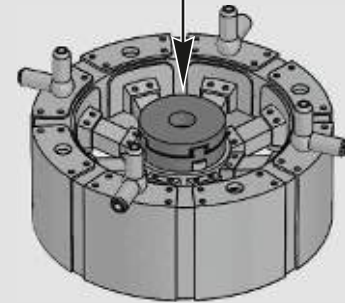

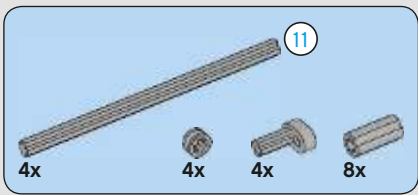

248

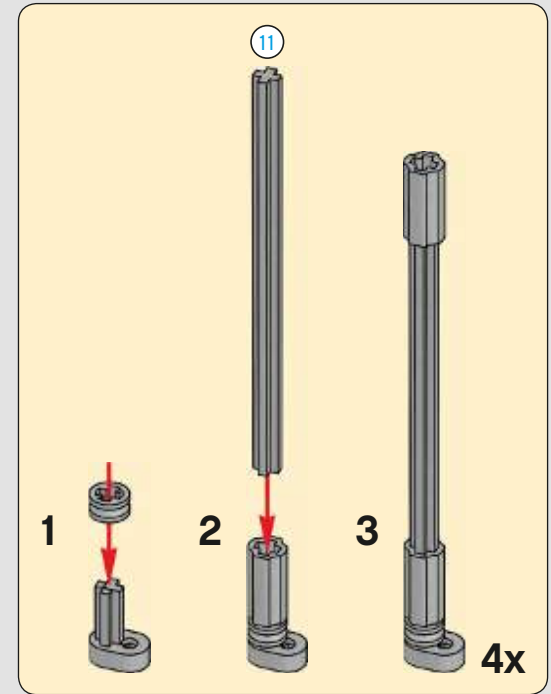
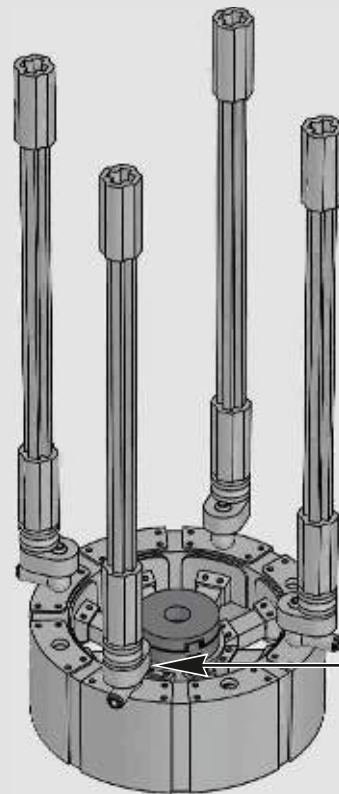
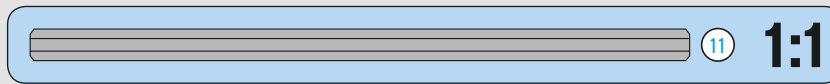

249

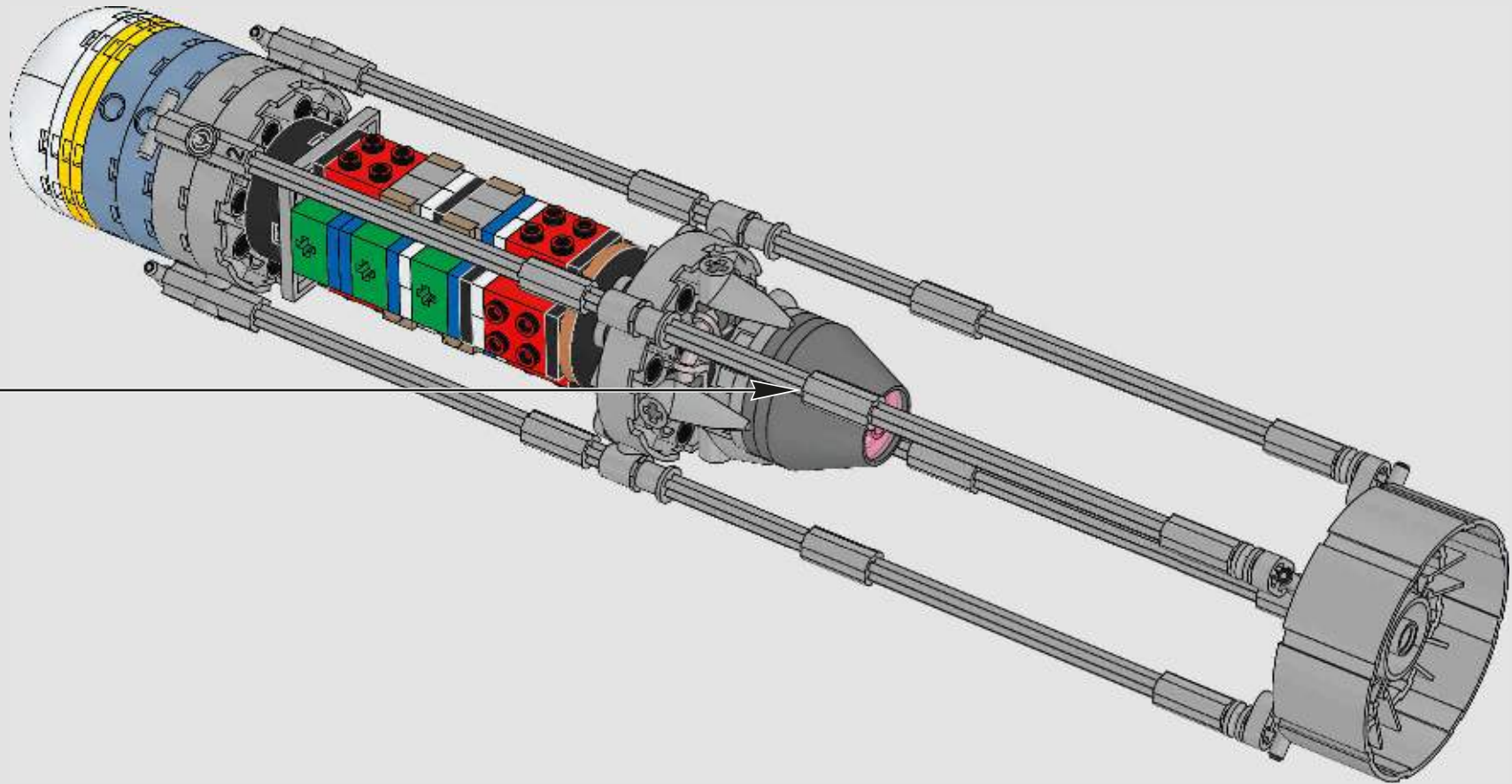

1x 4x 1x

250

1 2 3 4

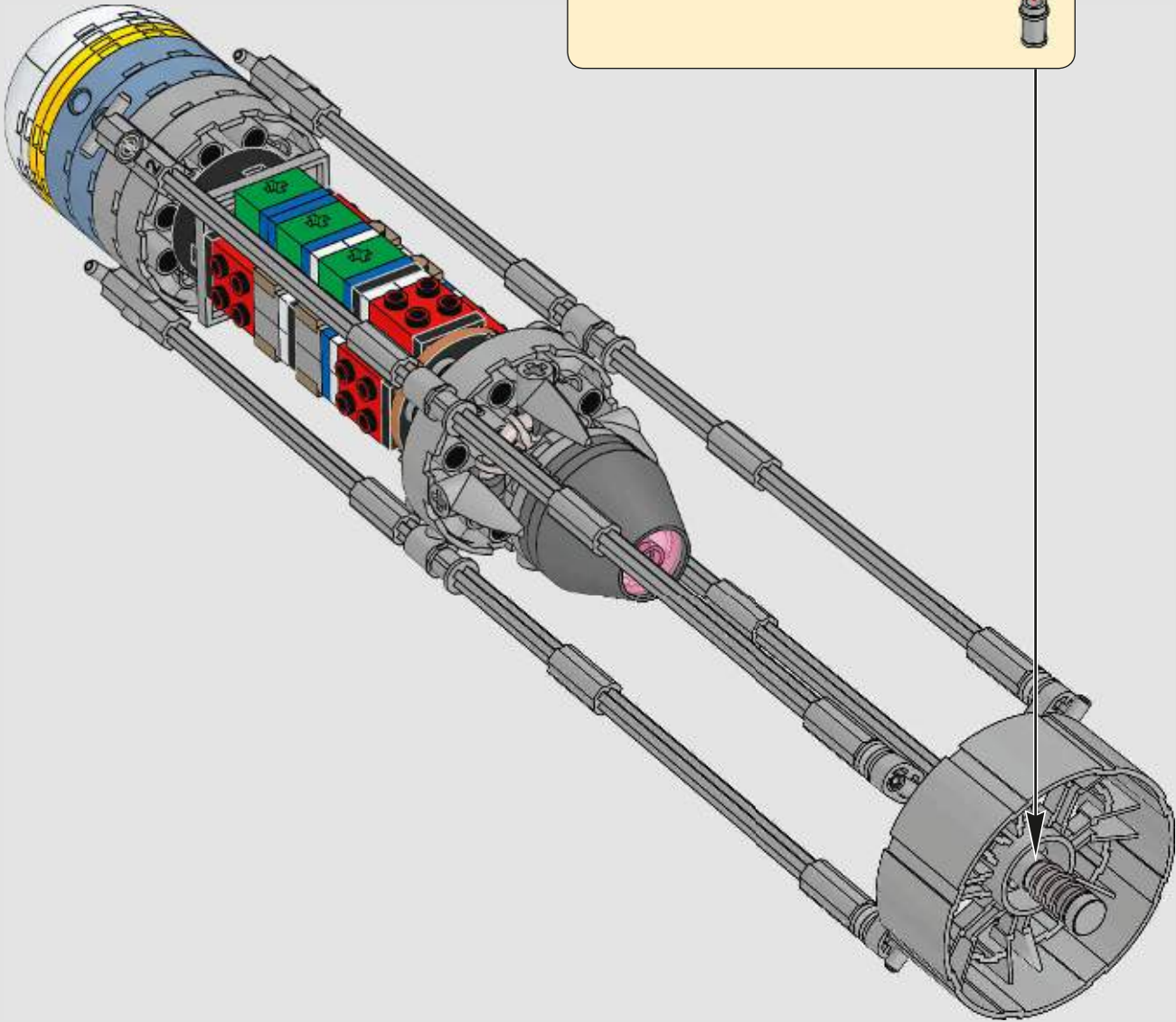

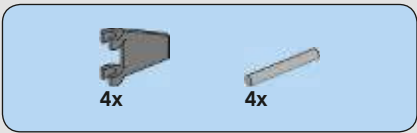

251

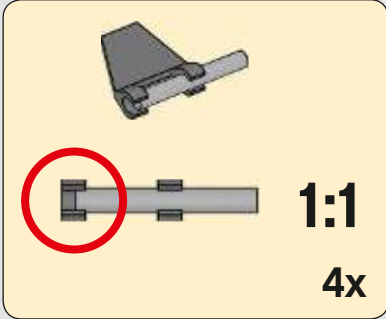
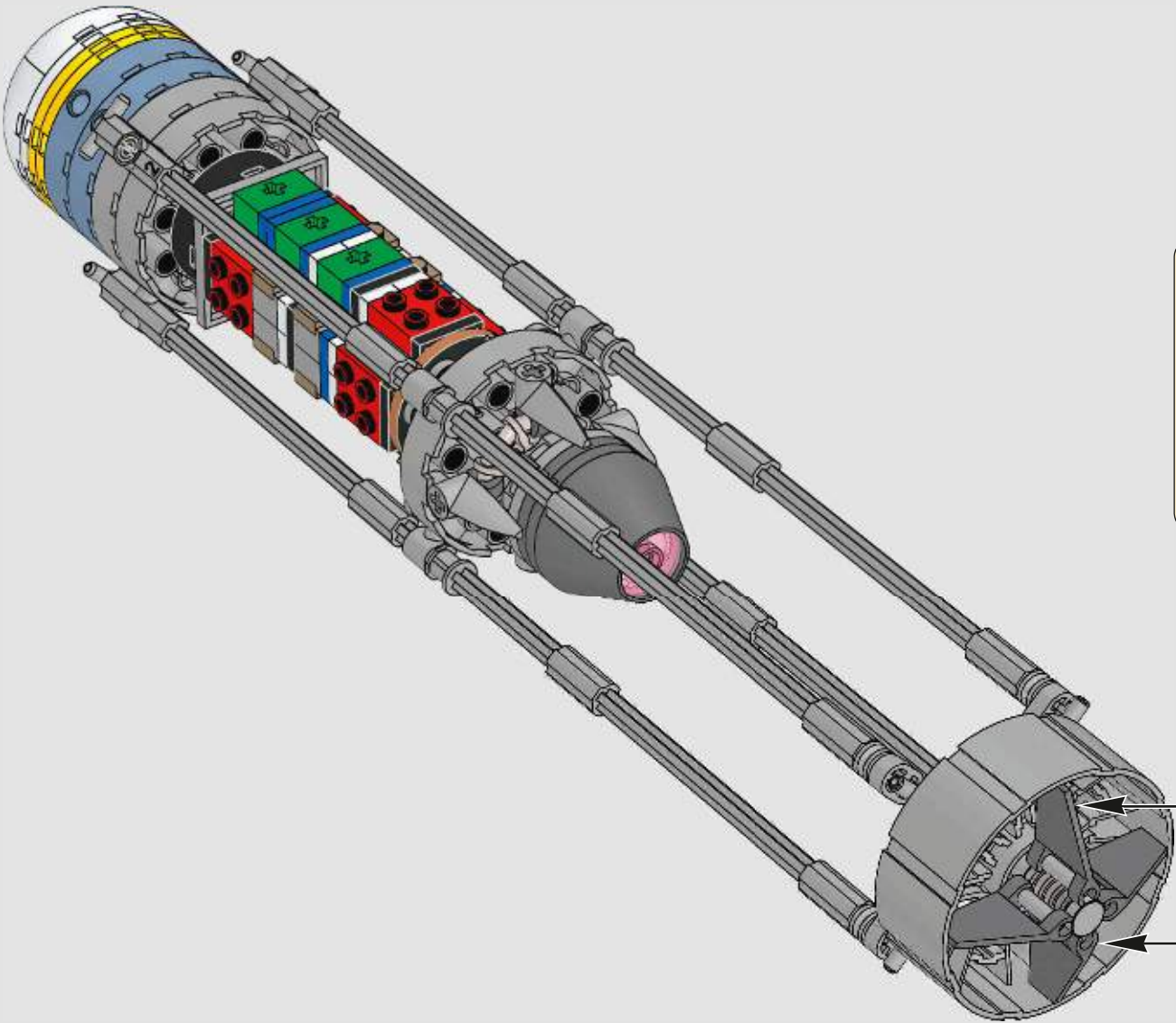

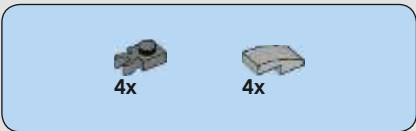

252

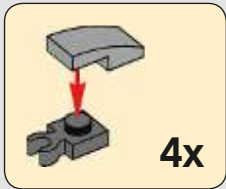
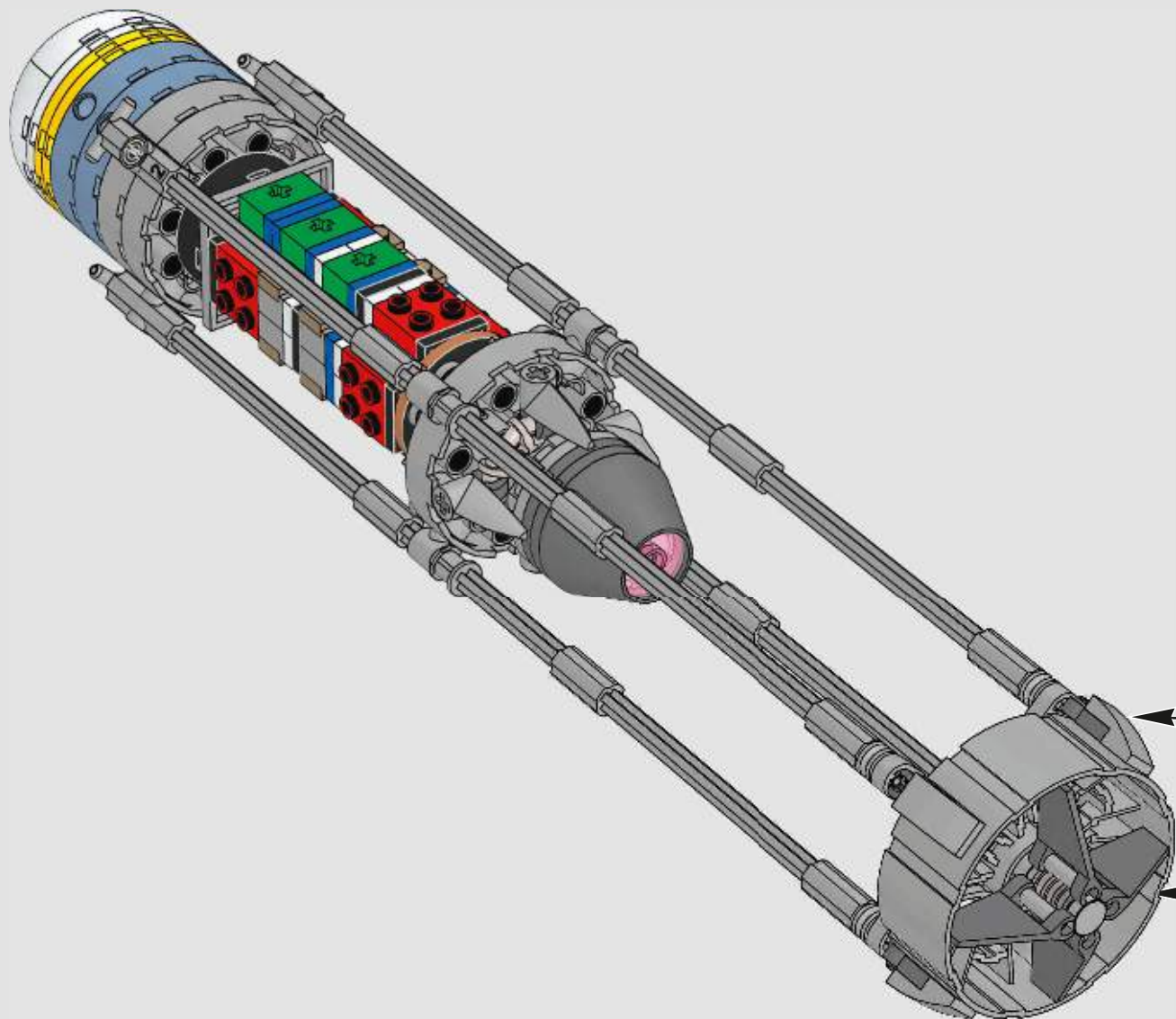



253

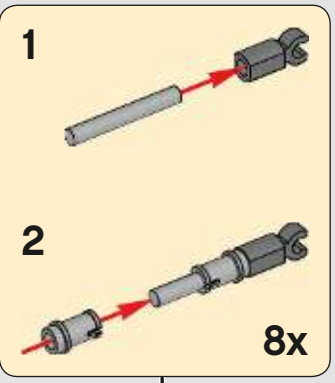
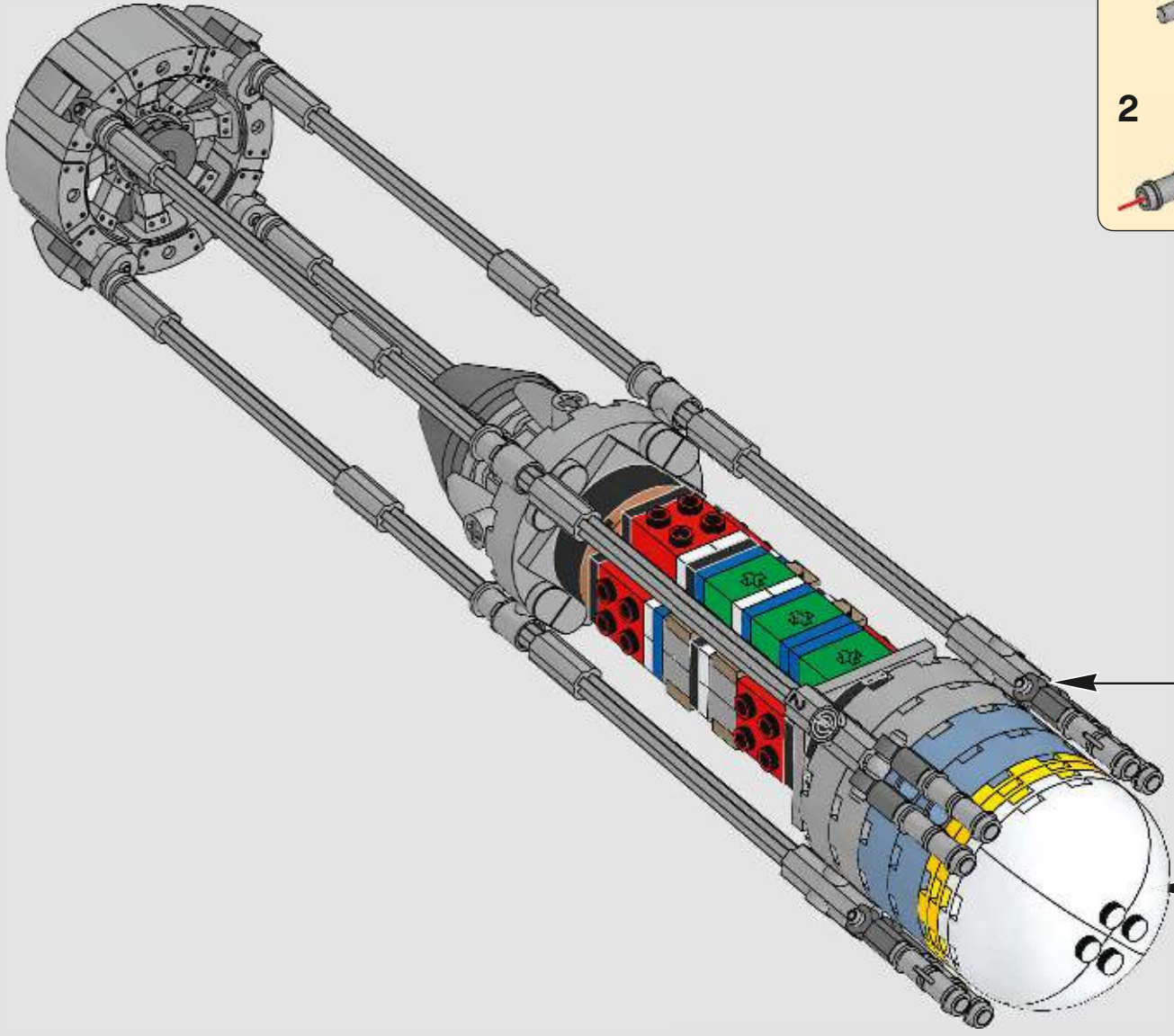

2x

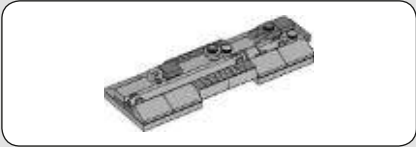
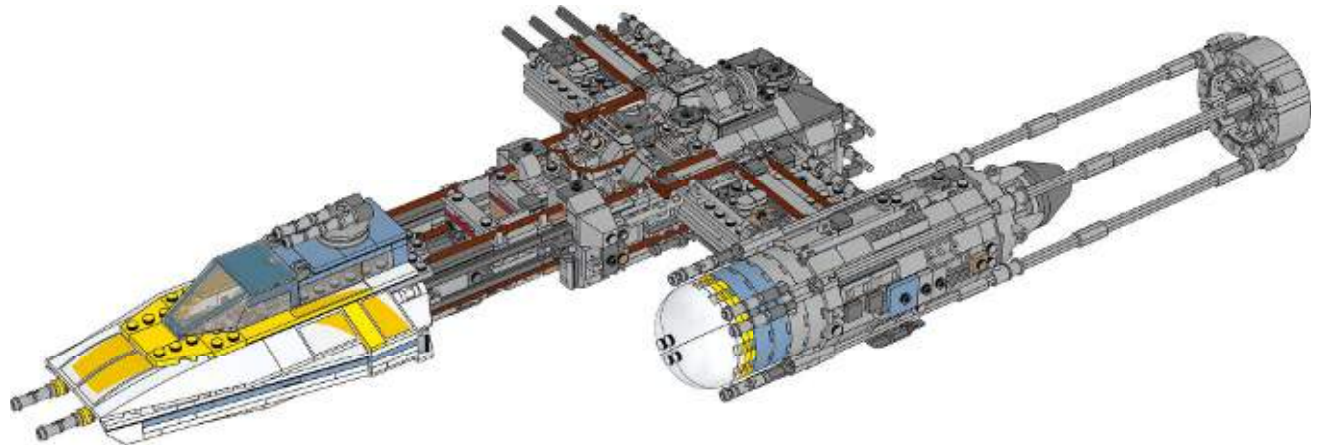

254

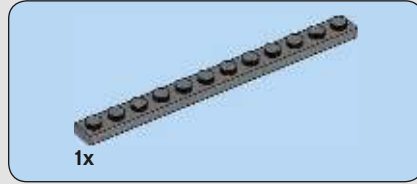
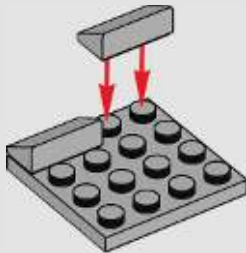

255

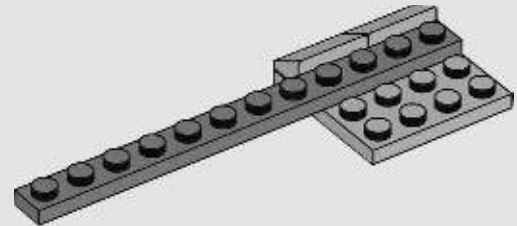

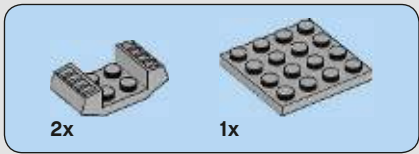

256

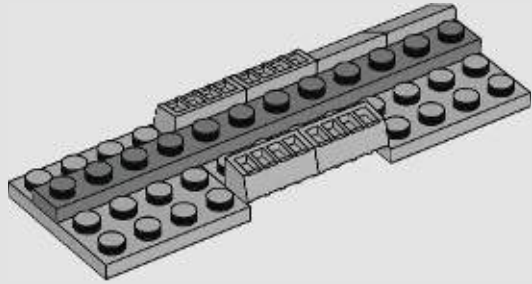

257

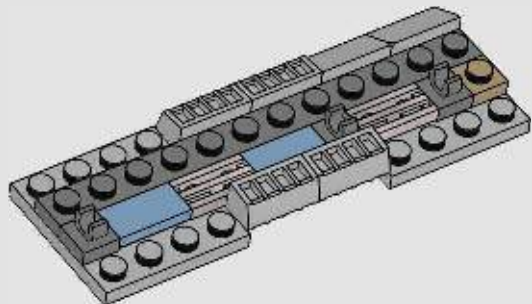

258

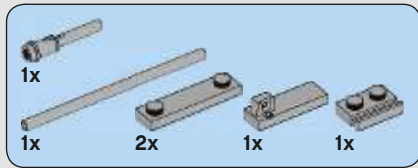
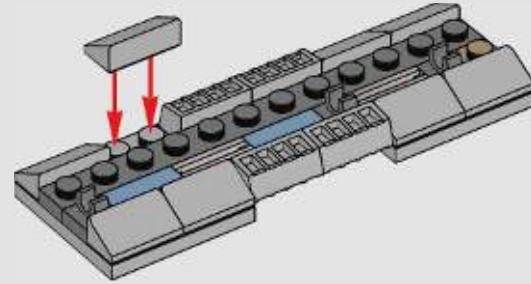

259

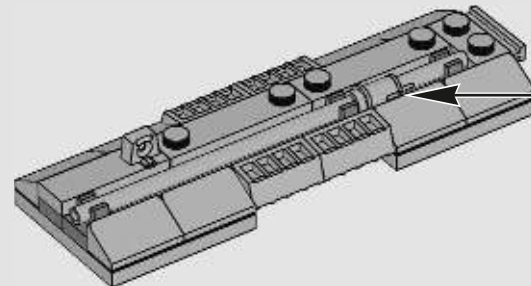
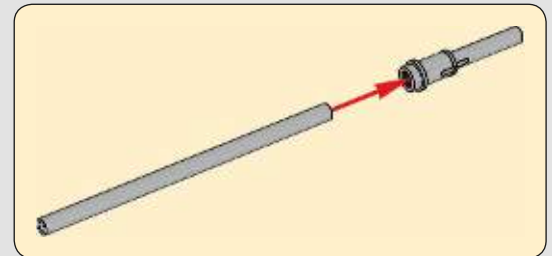

2x 1x 1x

260

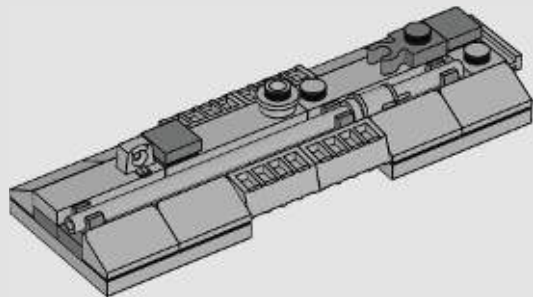

261

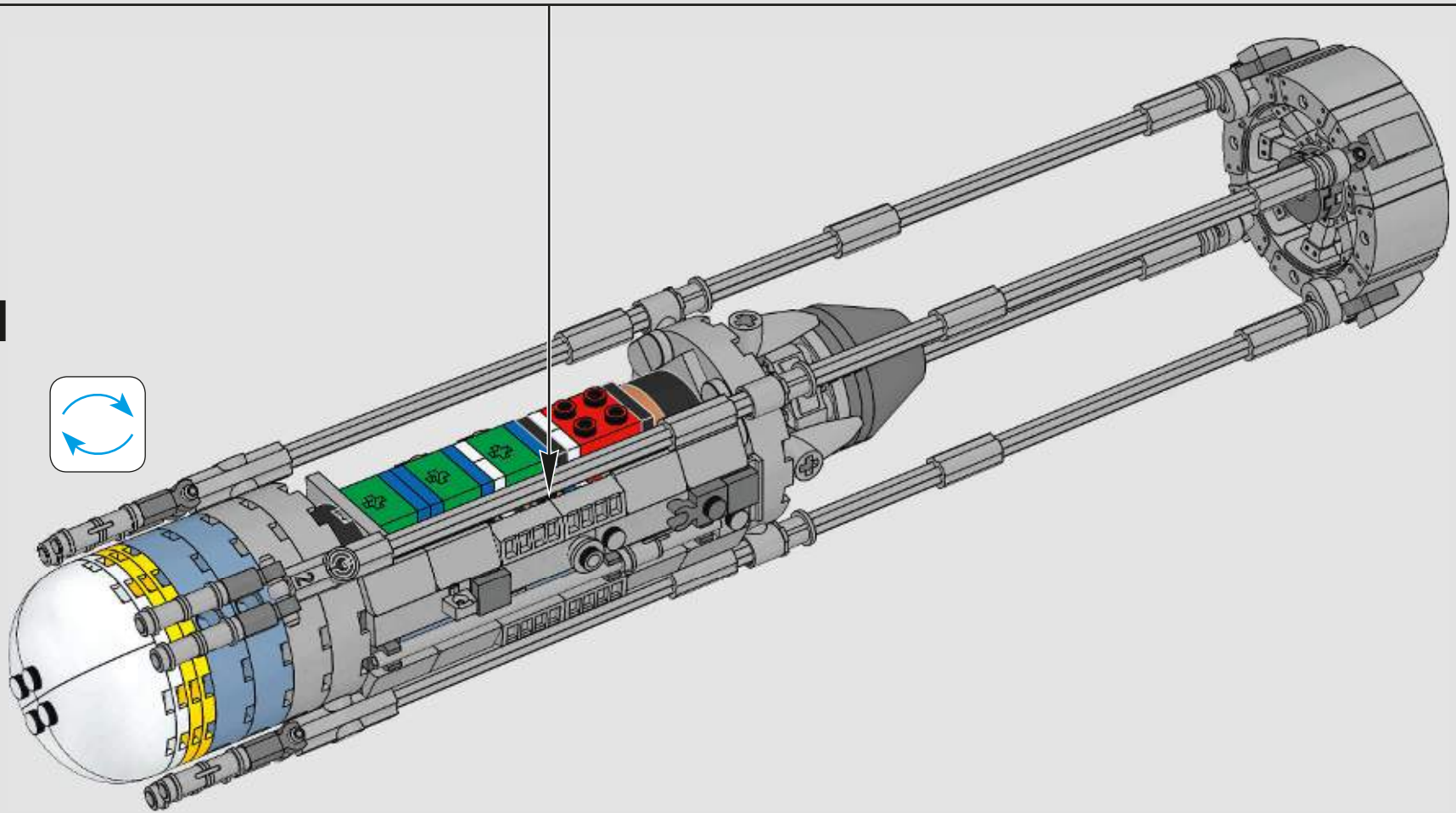
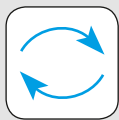

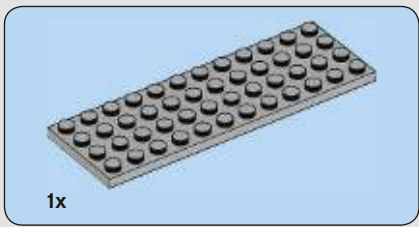

262

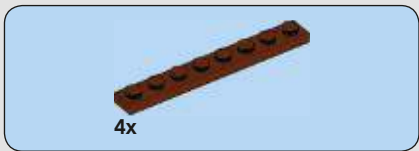
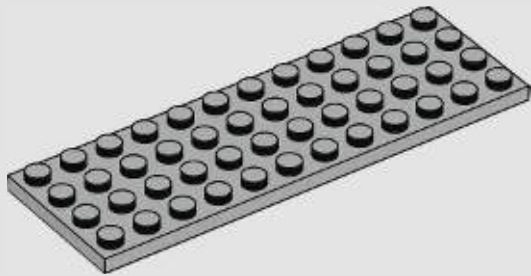

263

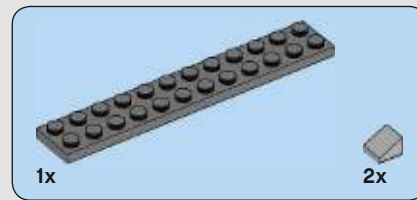
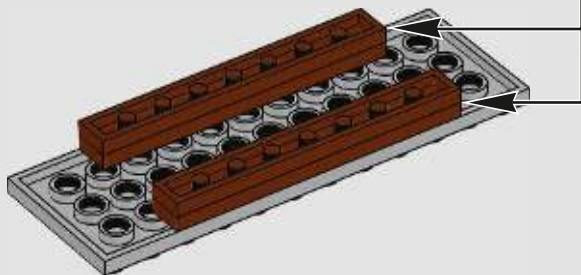
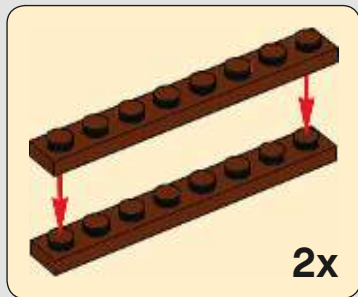
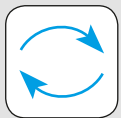

264

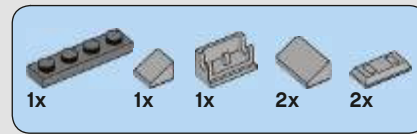
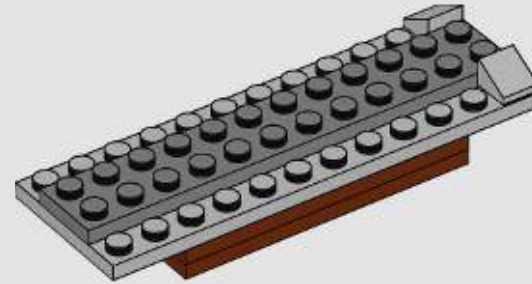
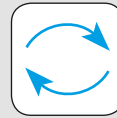

265

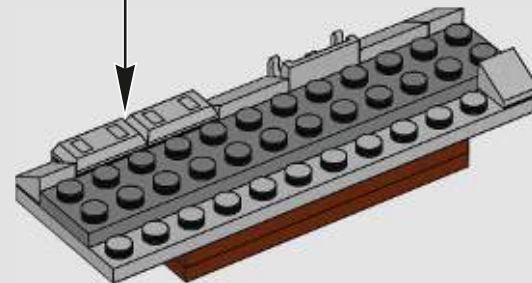
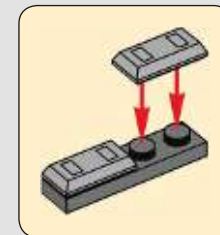

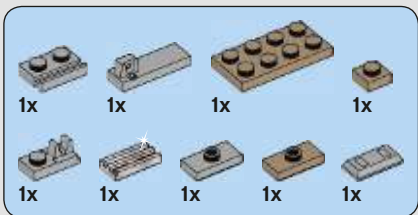

266

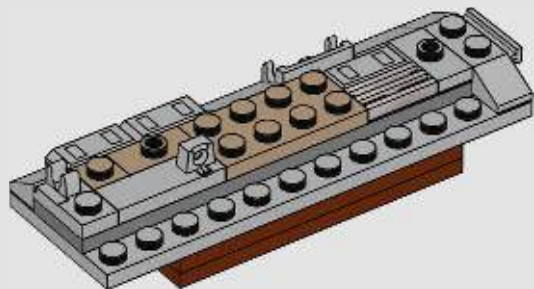

267

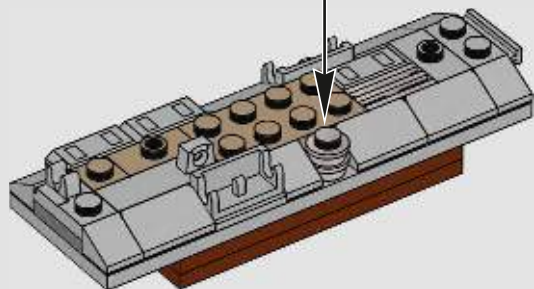

268

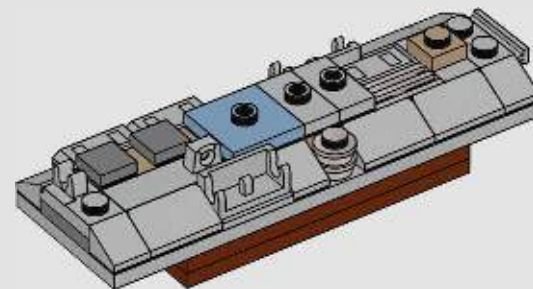

269

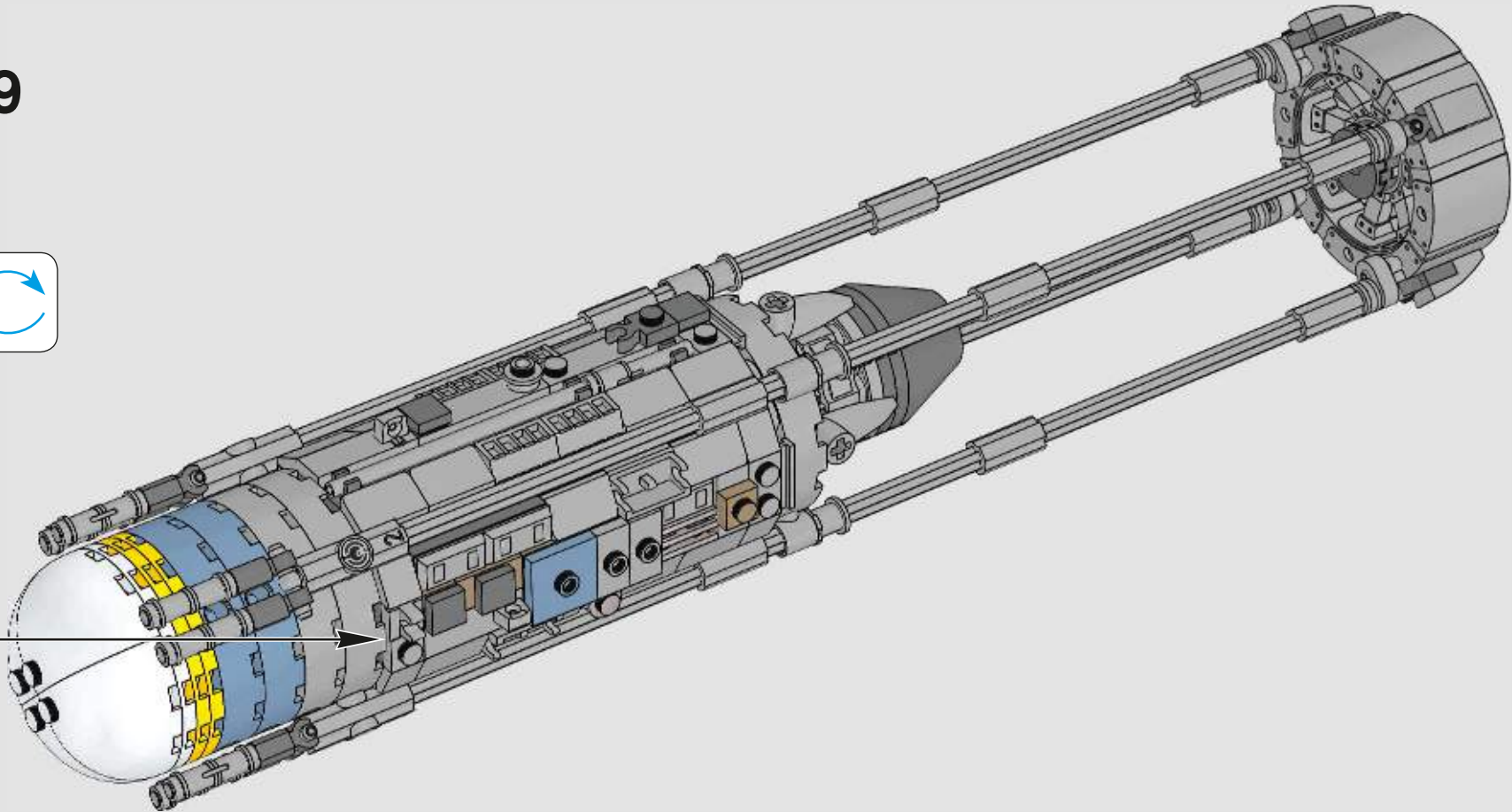

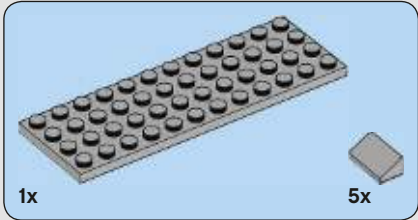

270

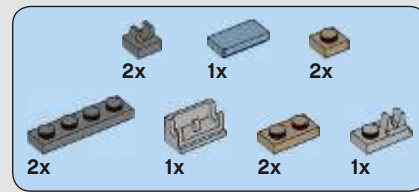
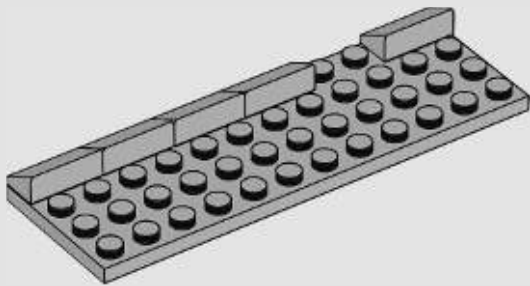

271

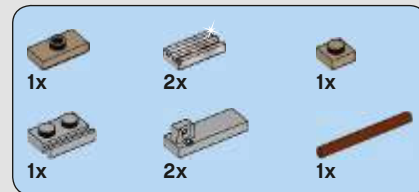
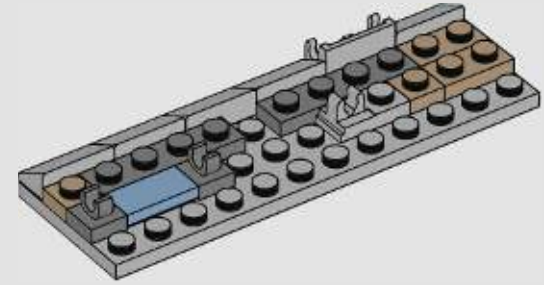

272

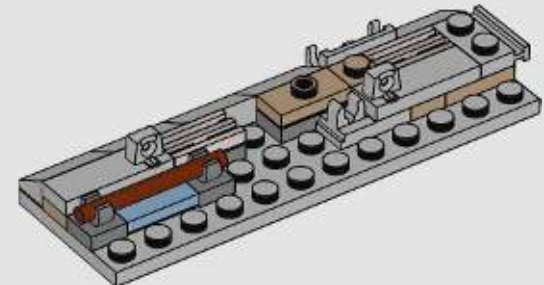

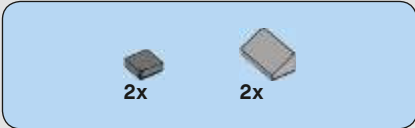

273

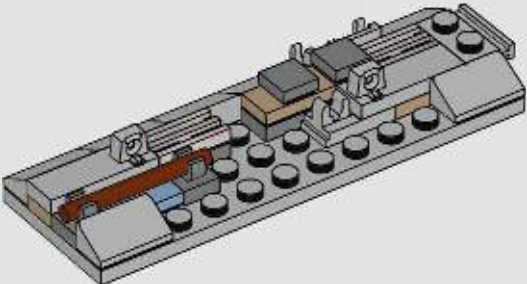

274

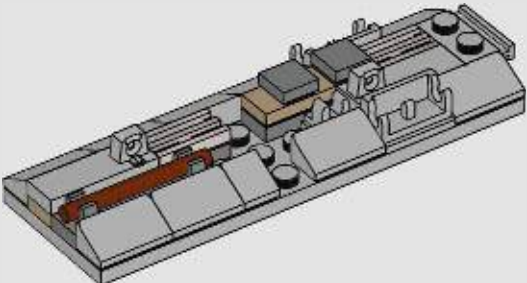

275

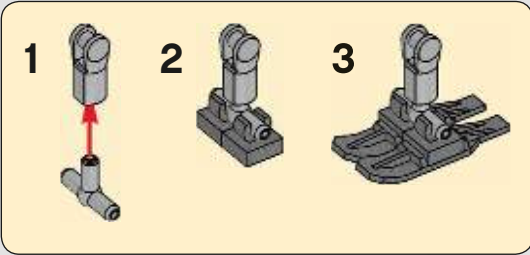
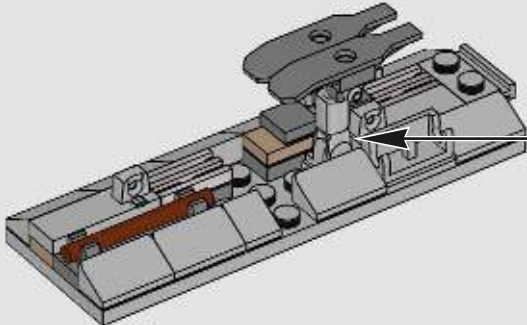

276

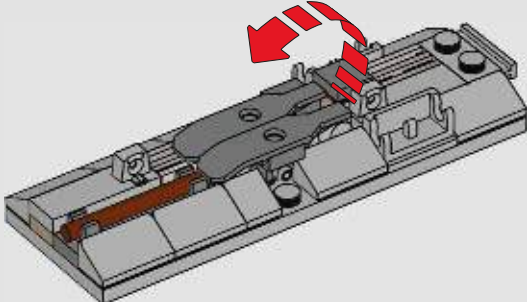

277

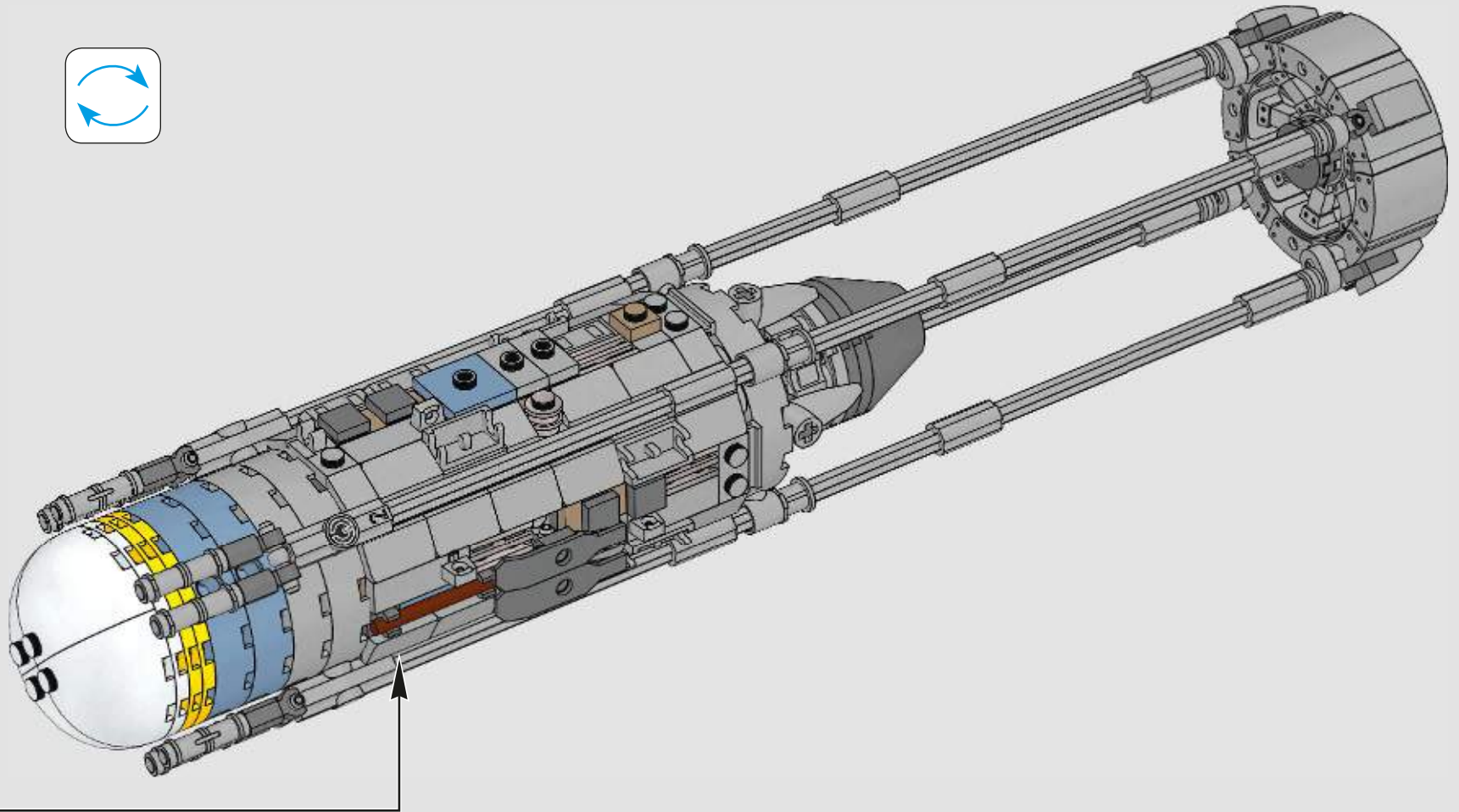

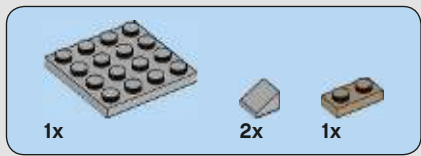

278

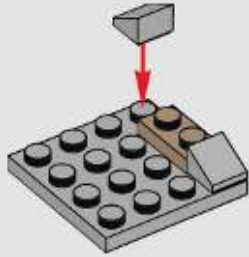

279

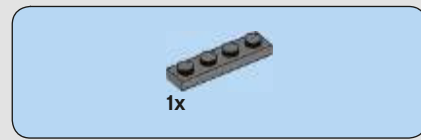
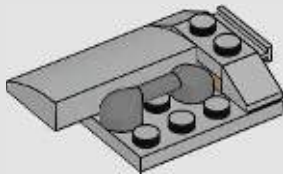

280

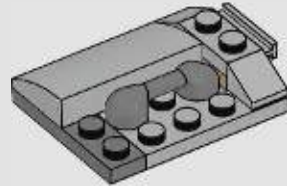

281

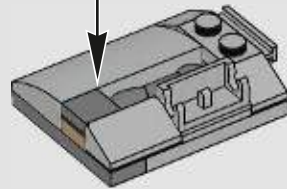

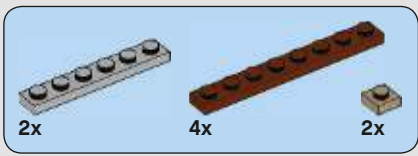

282

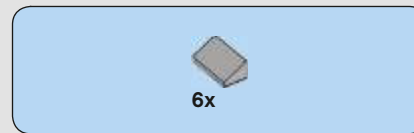
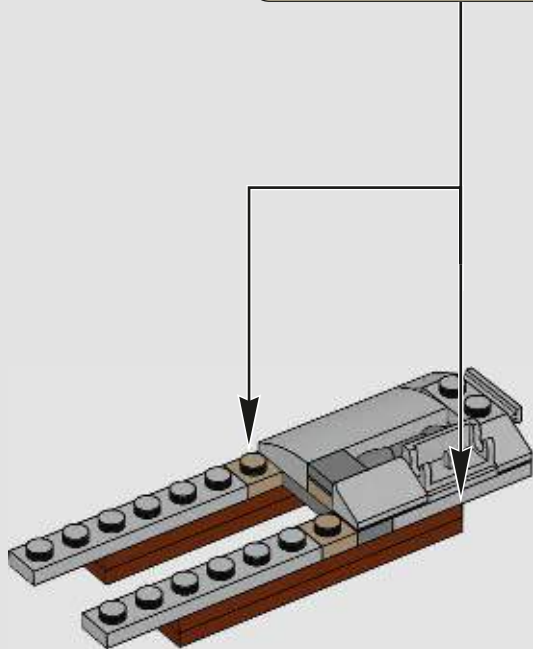
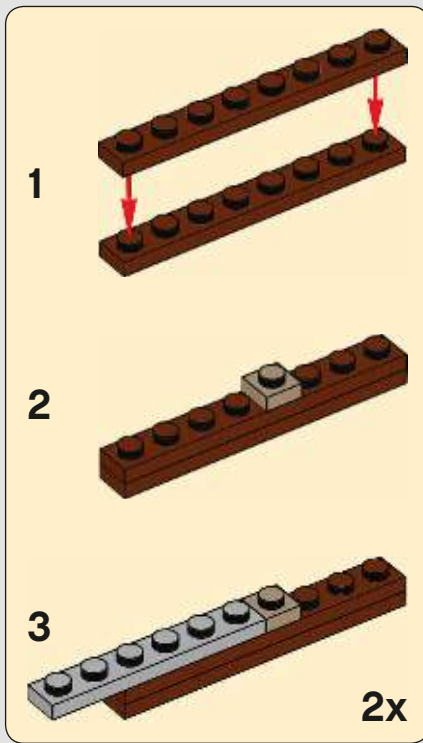

283

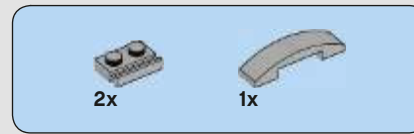
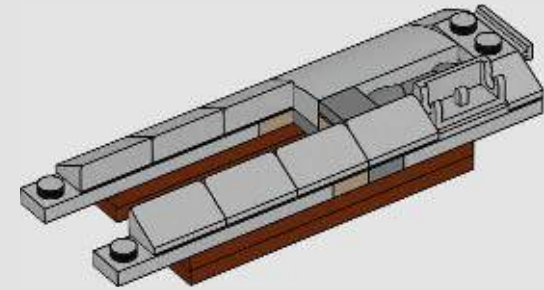

284

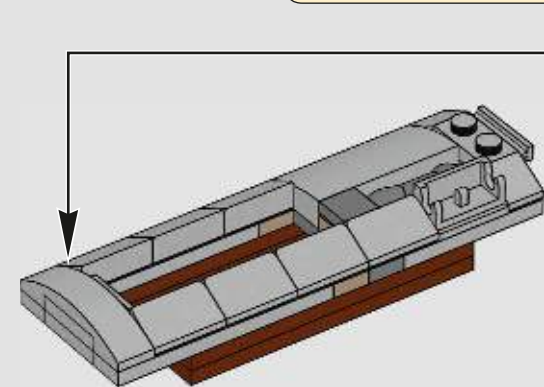
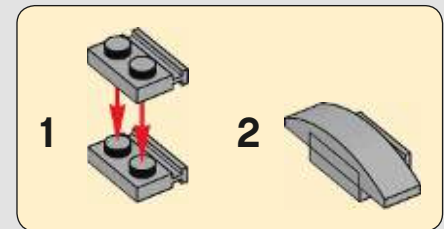

285

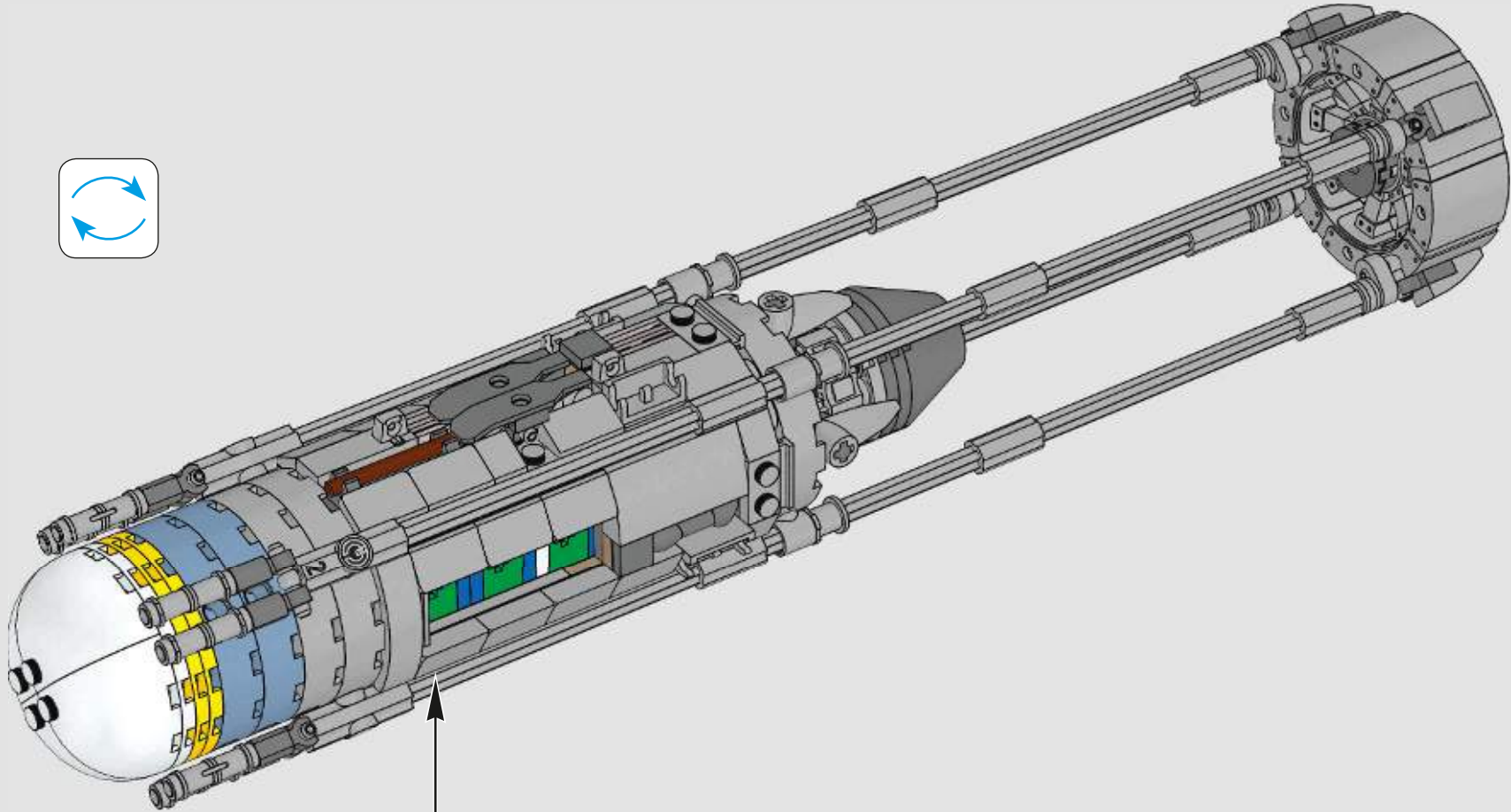

286

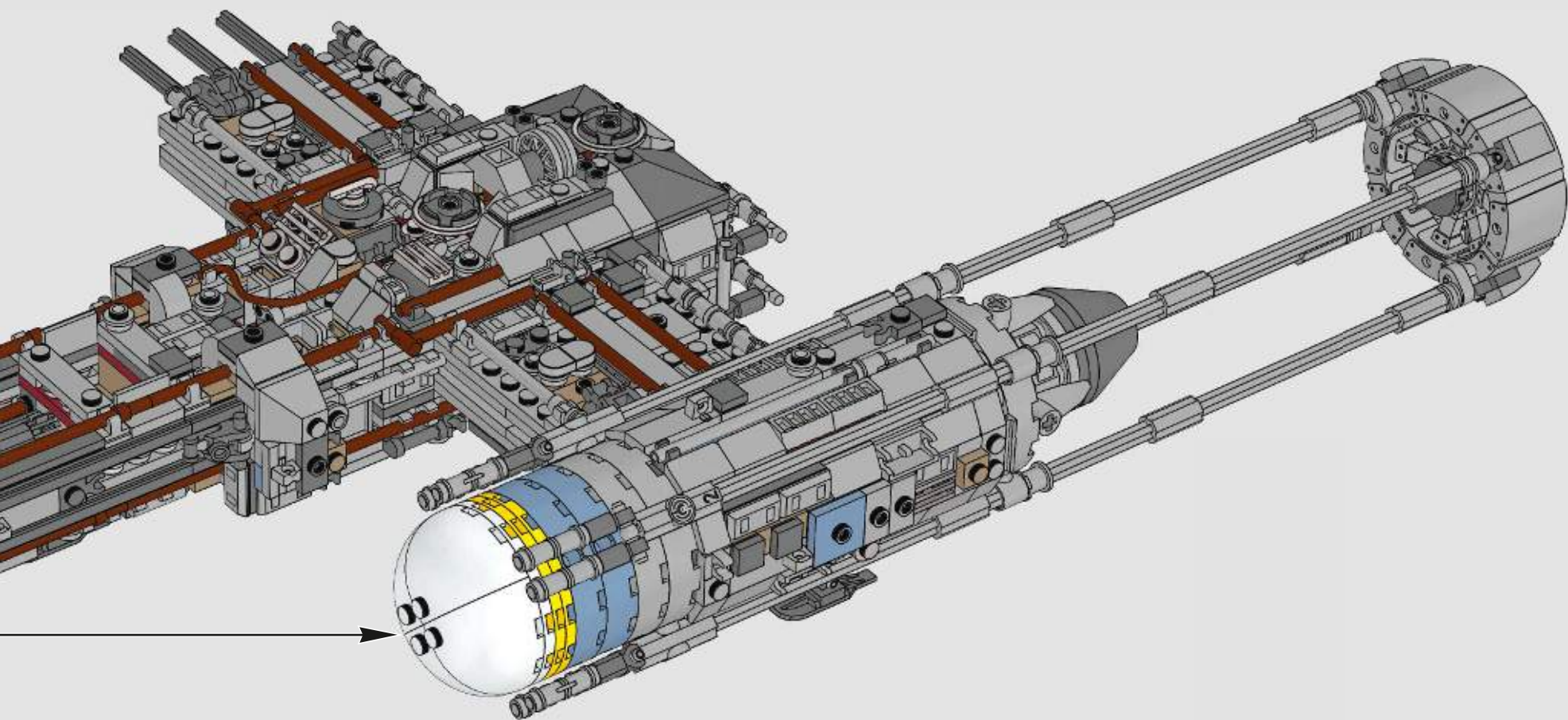



12

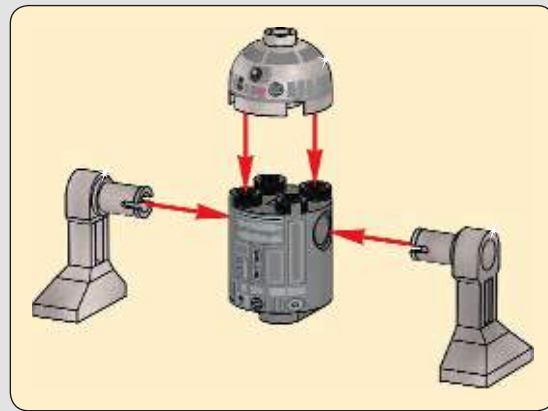
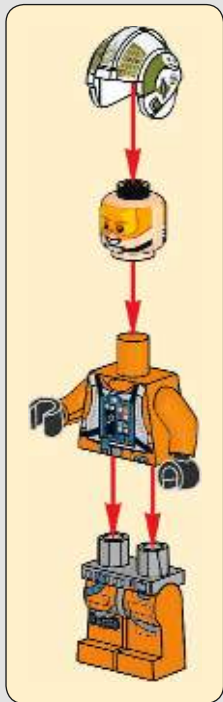
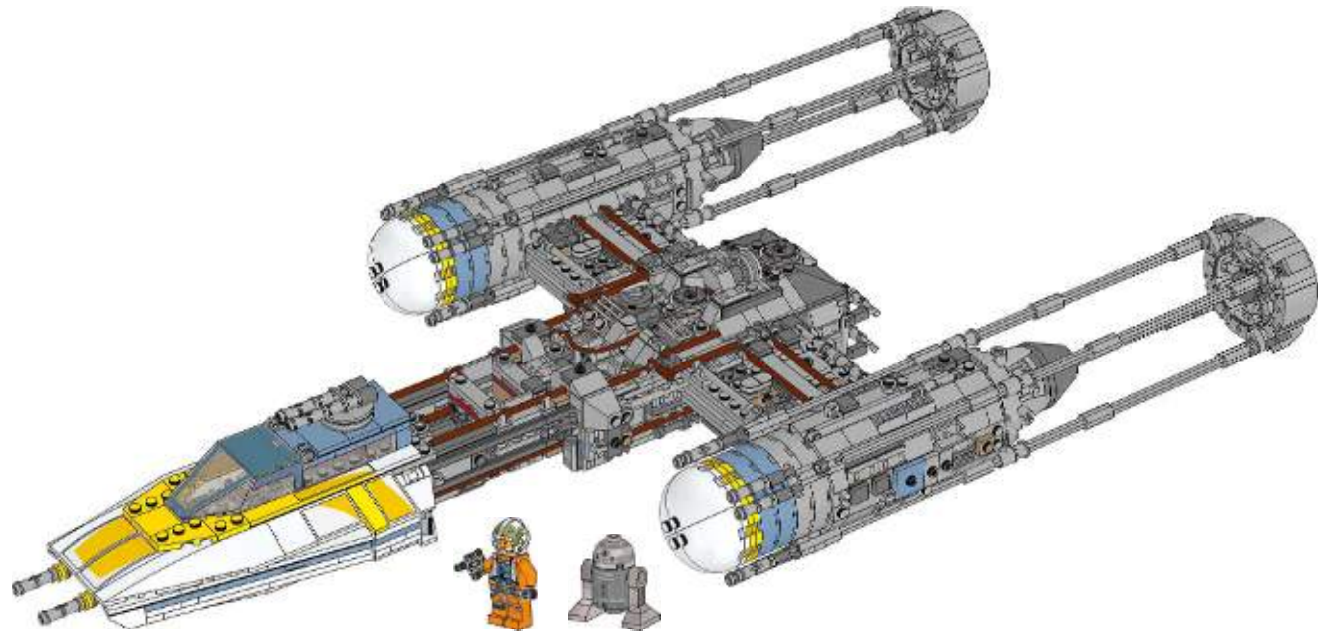

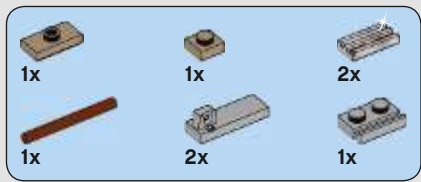

290

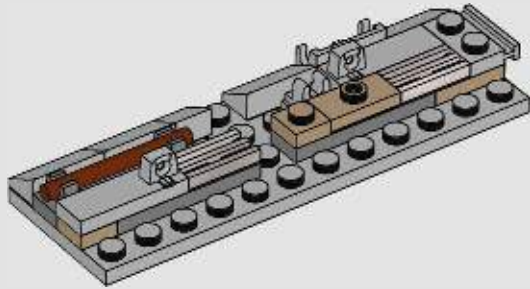

291

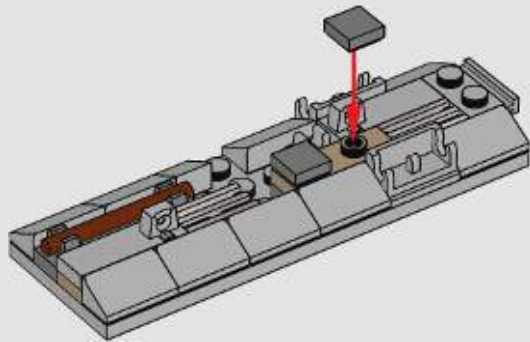

292

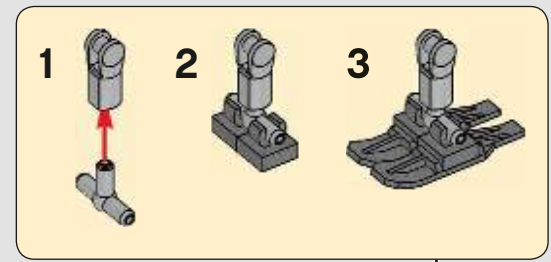
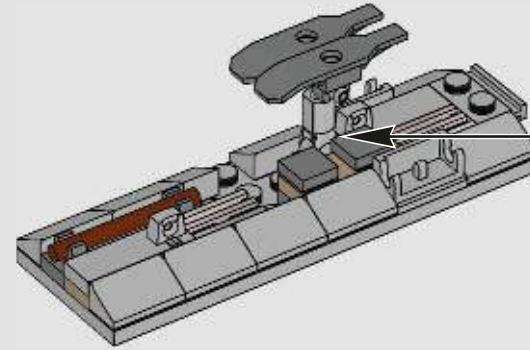

293

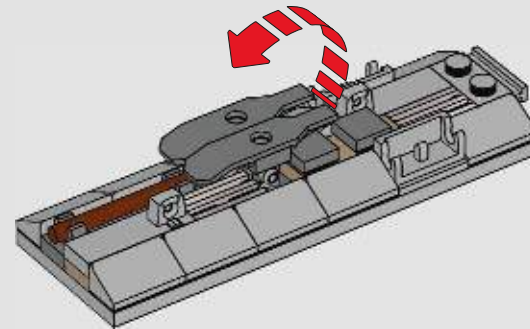

294

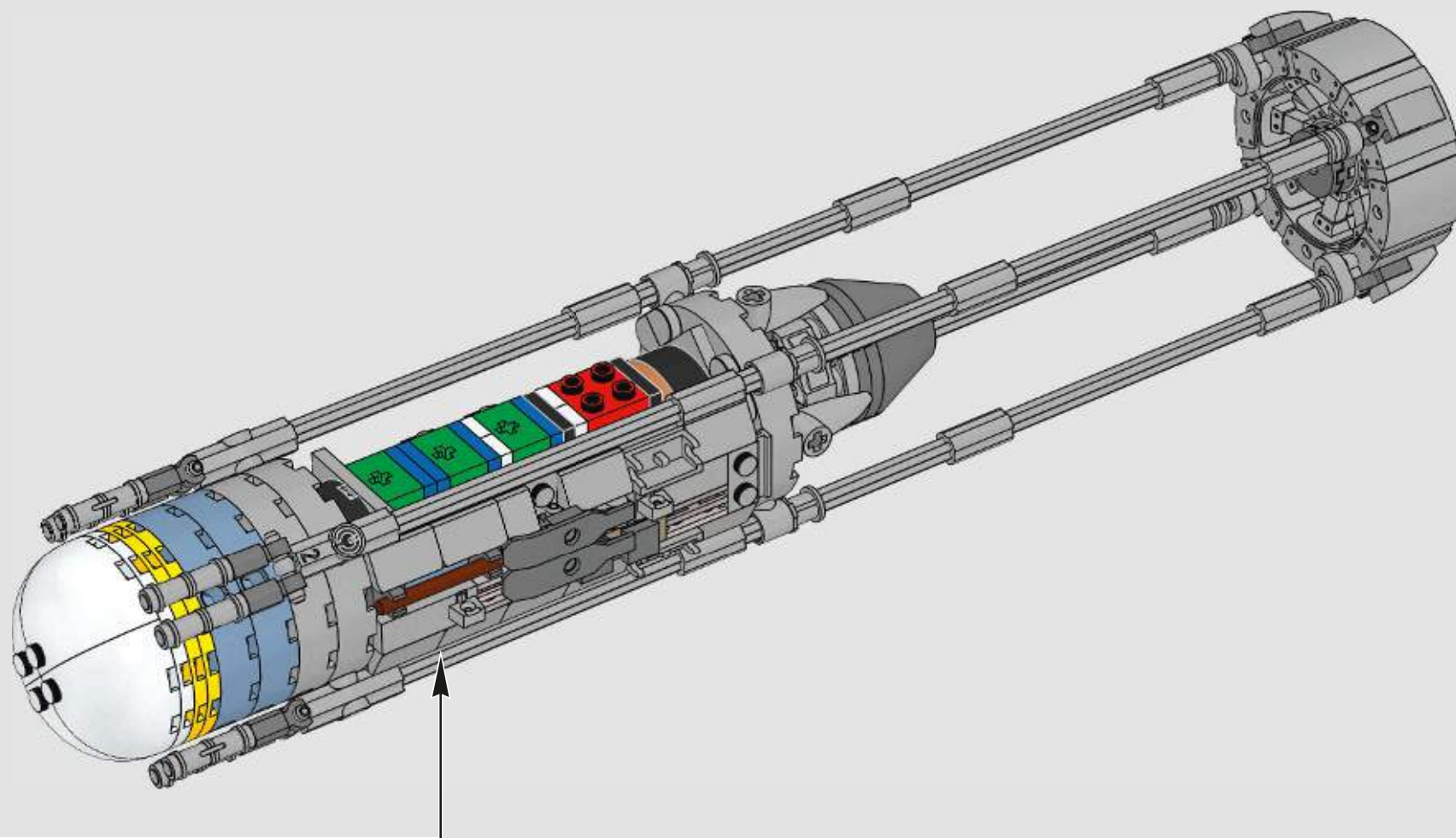

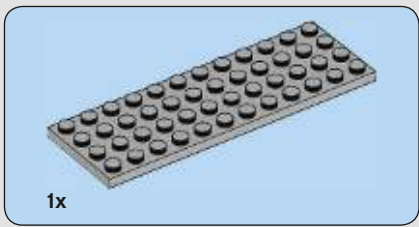

295

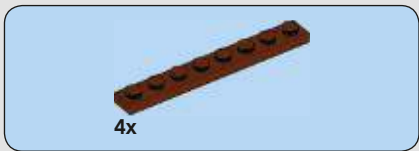
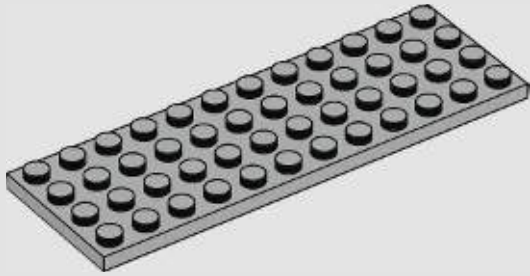

296

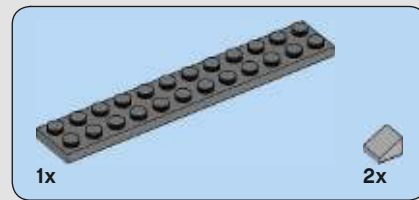
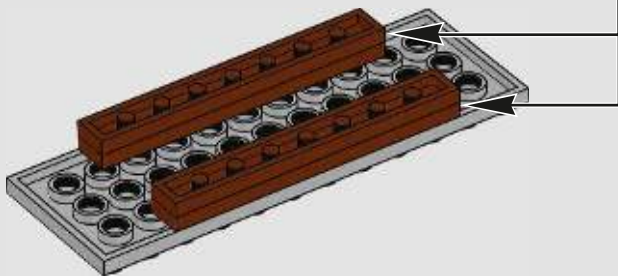
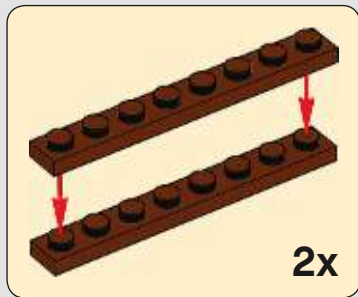

297

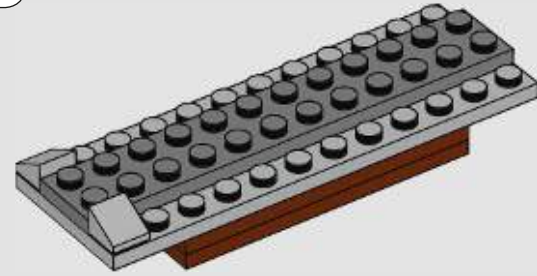

298

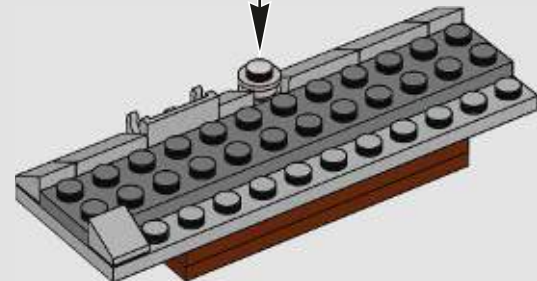

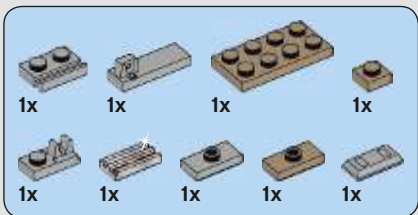

299

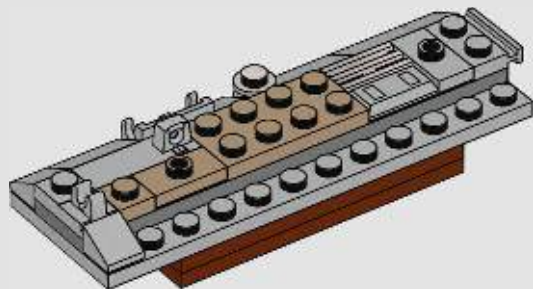

300

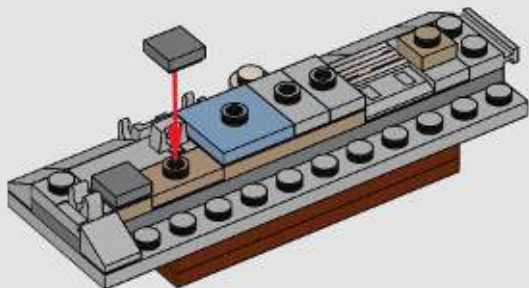

301

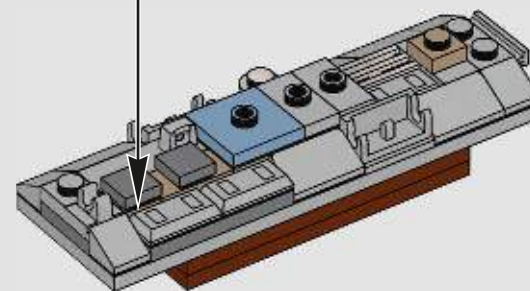
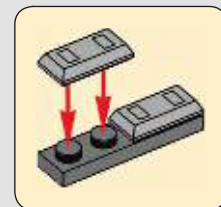

302

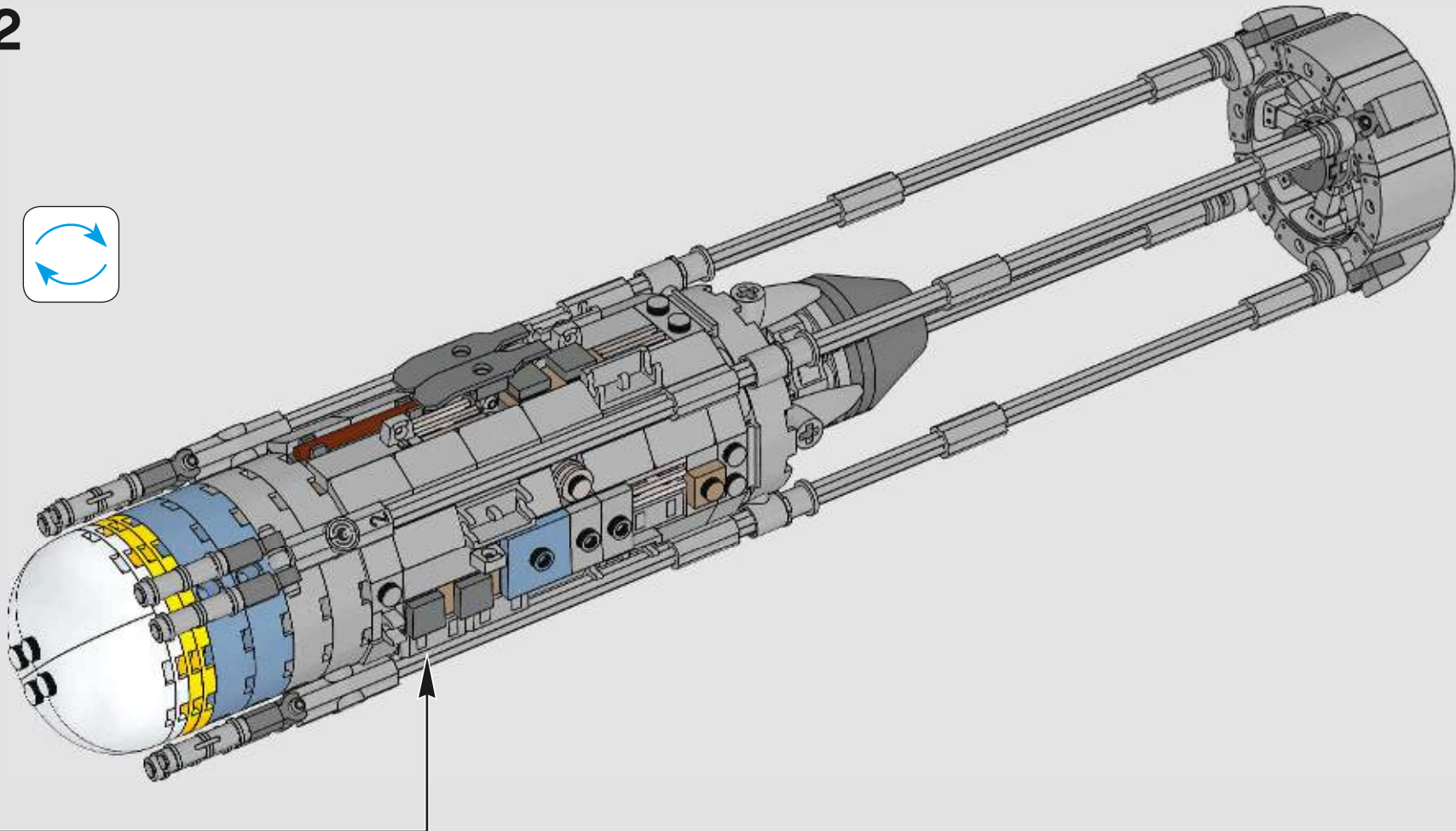

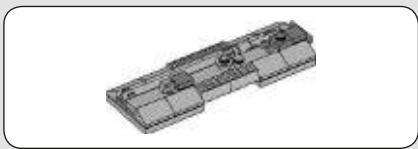

303

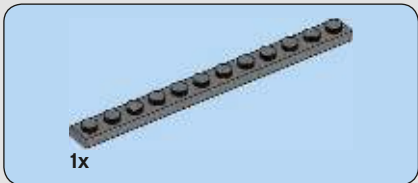
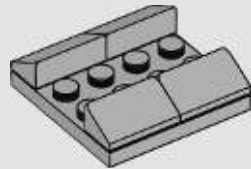

304

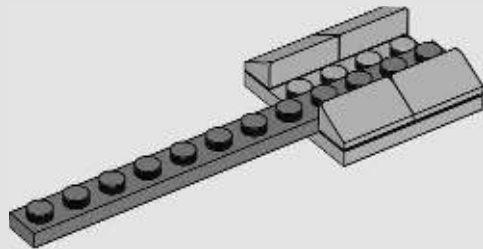

305

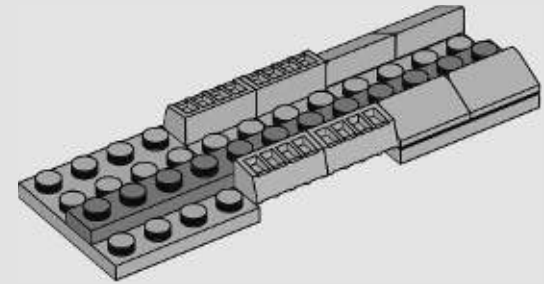

306

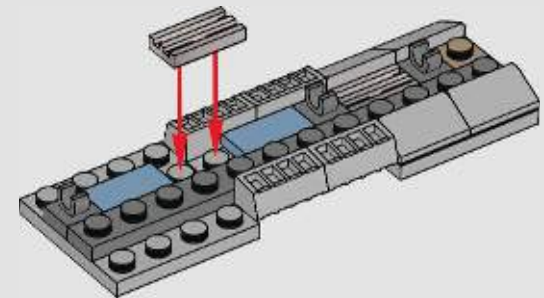



4x

307

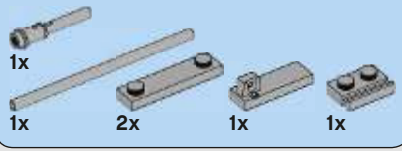
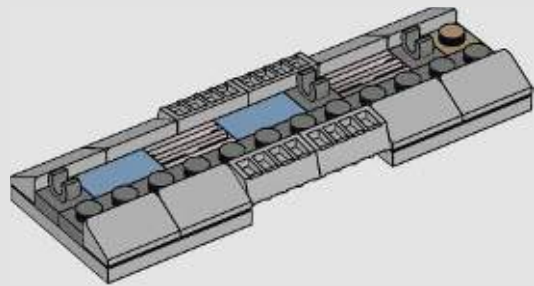

308

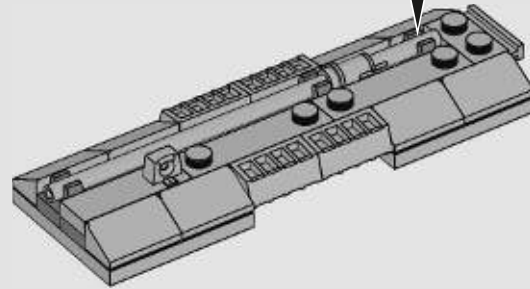
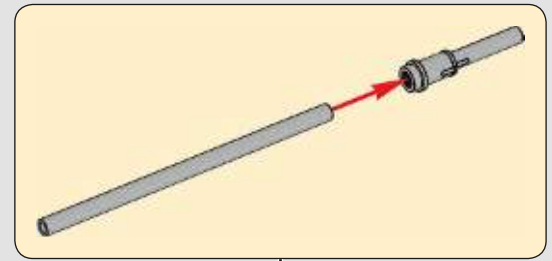

2x

1x

1x

309

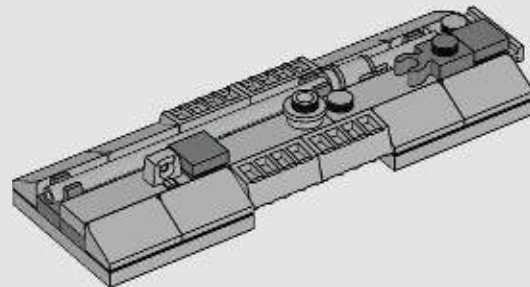

310

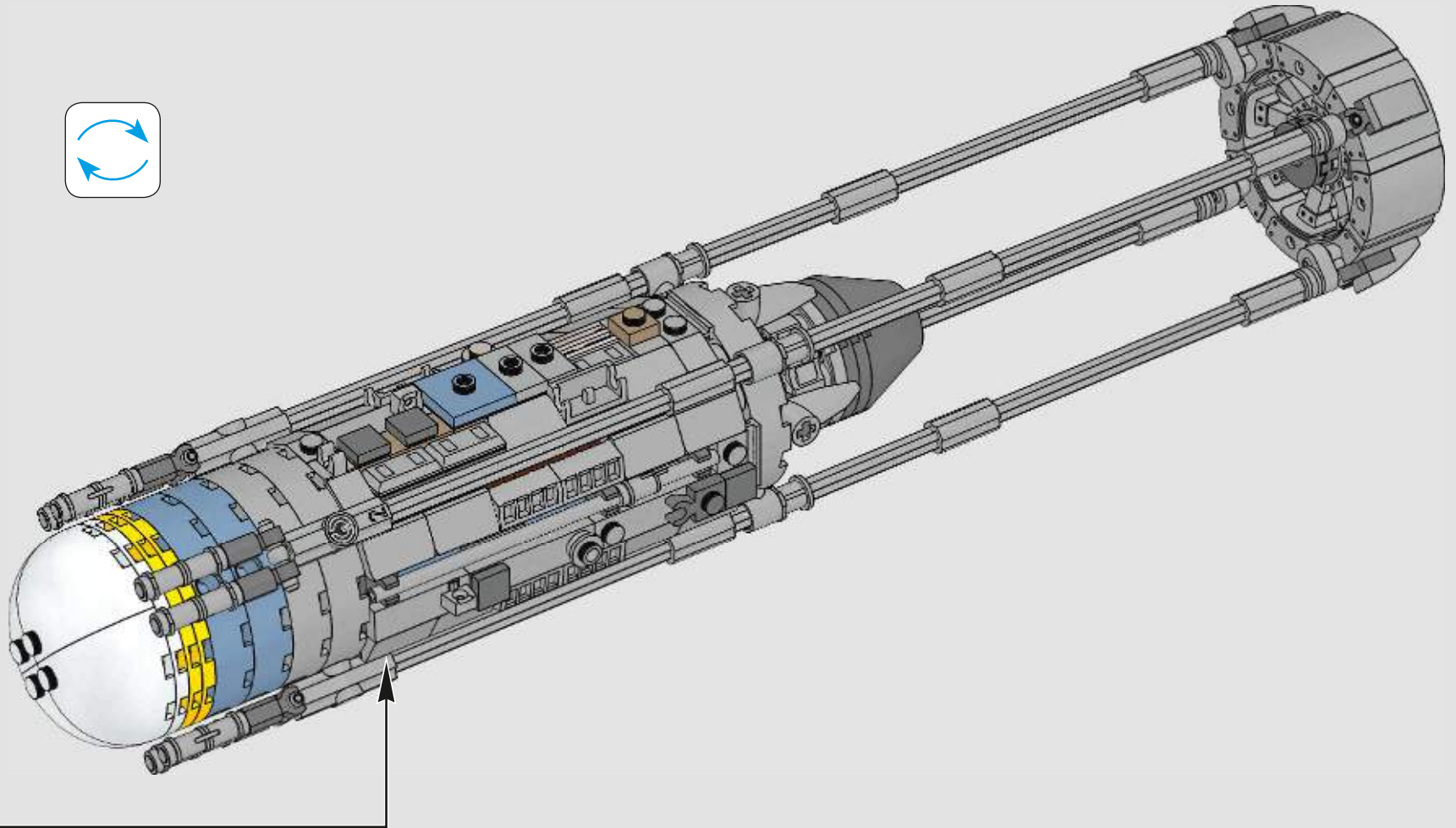

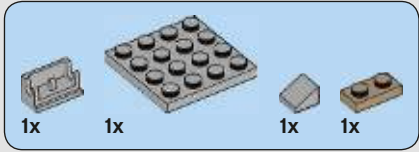
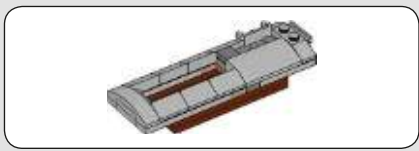

311

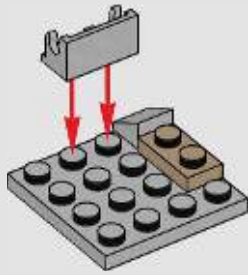

312

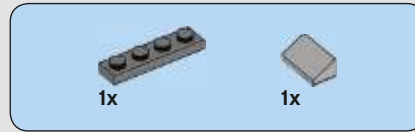
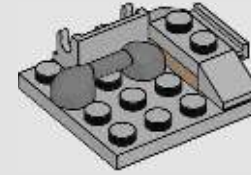

313

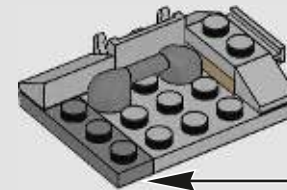
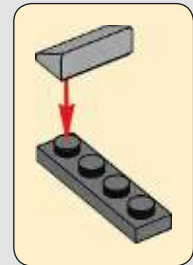

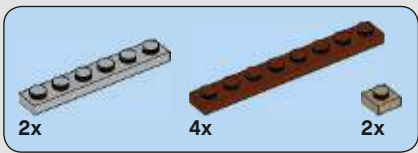

314

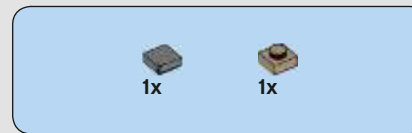
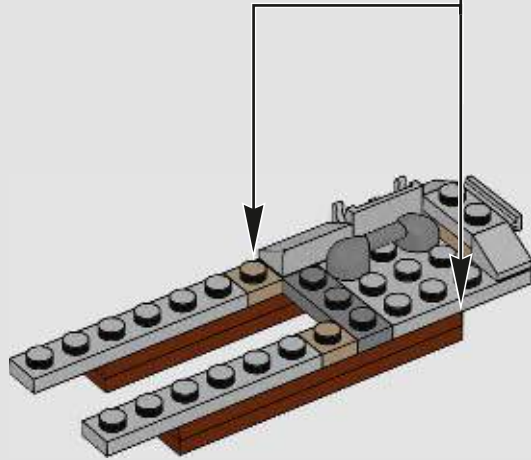
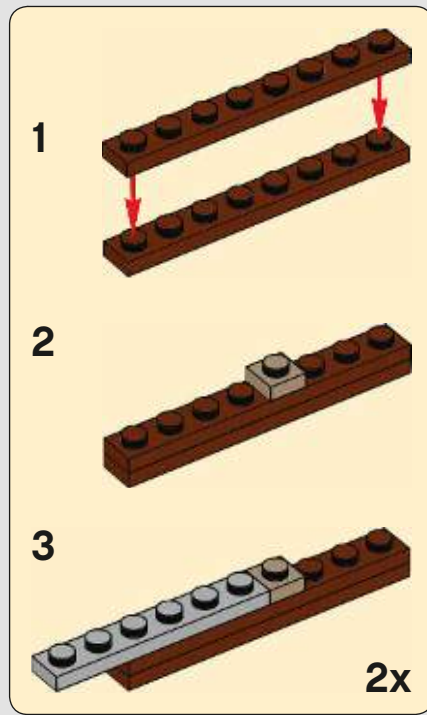

315

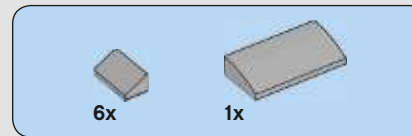
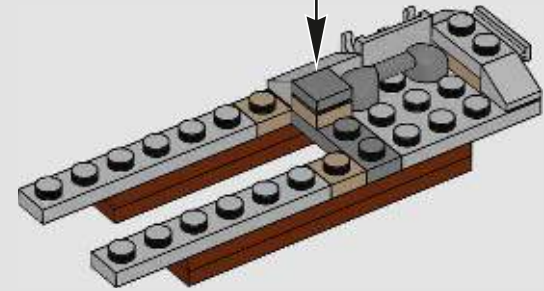

316

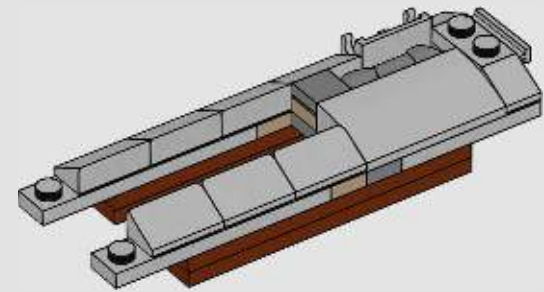

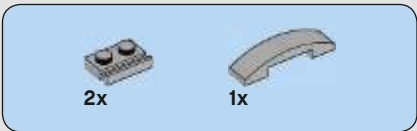

317

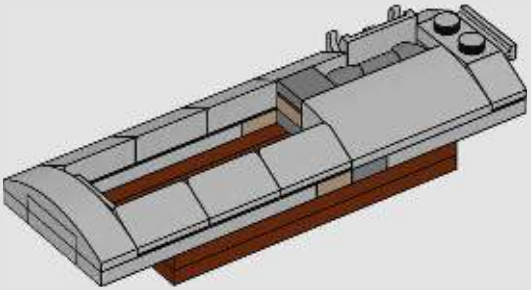
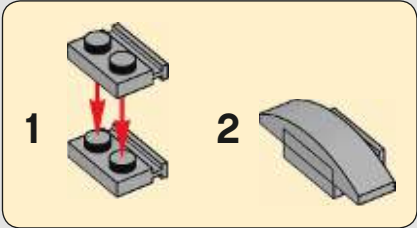

318

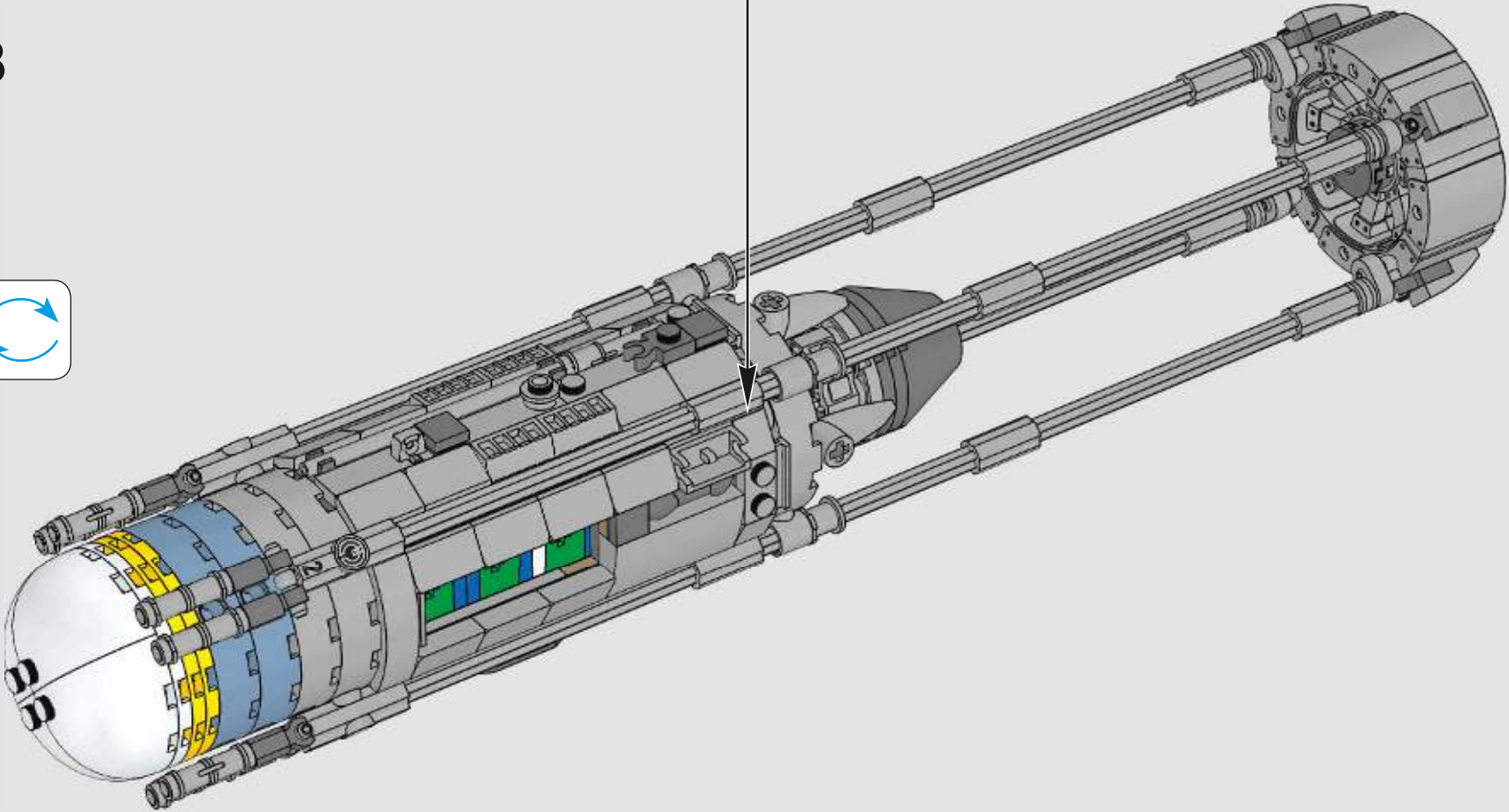

319

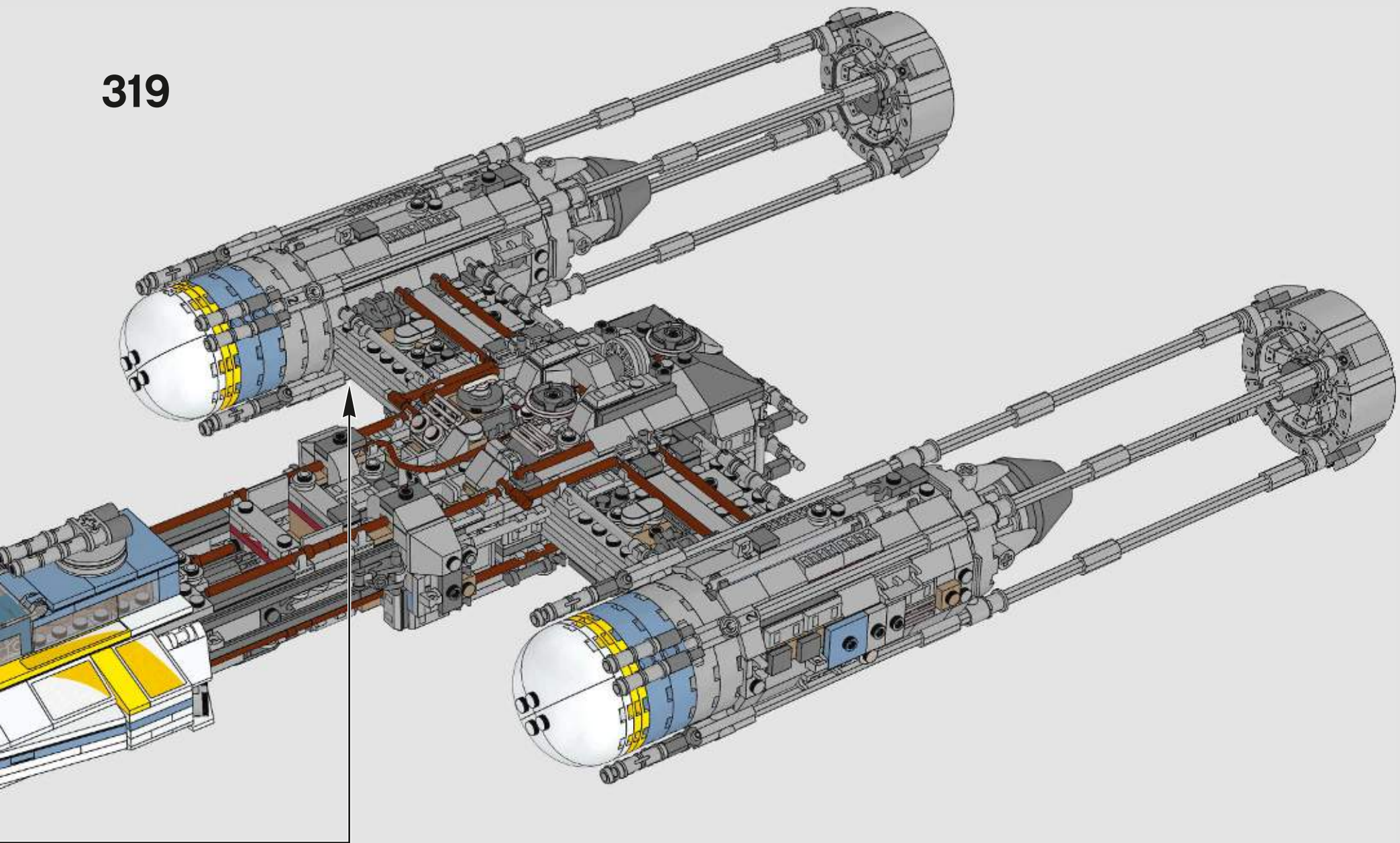

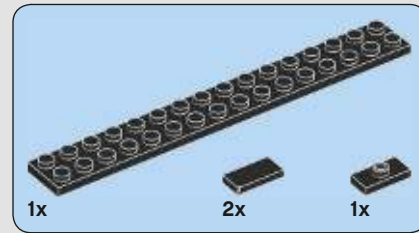
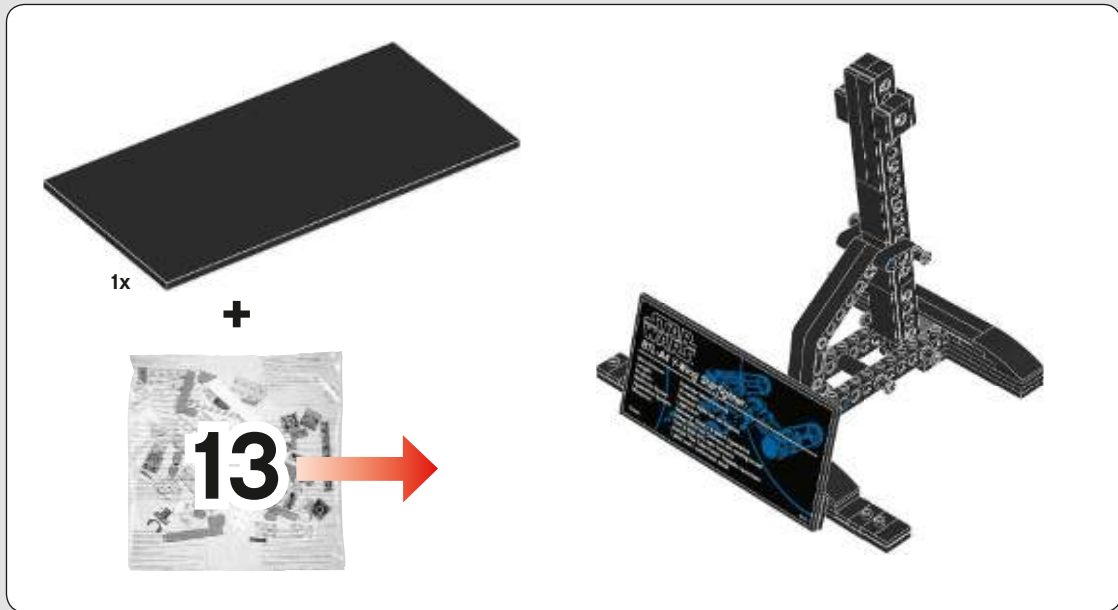

321



320

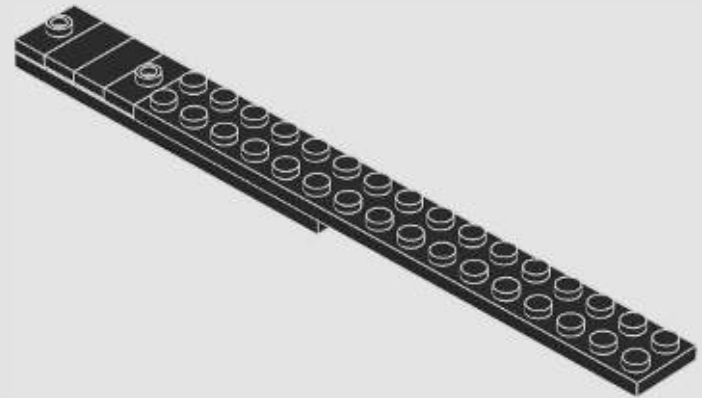
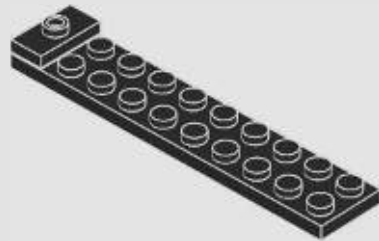

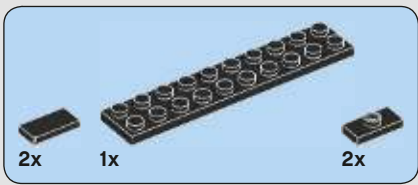

322

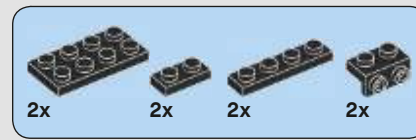
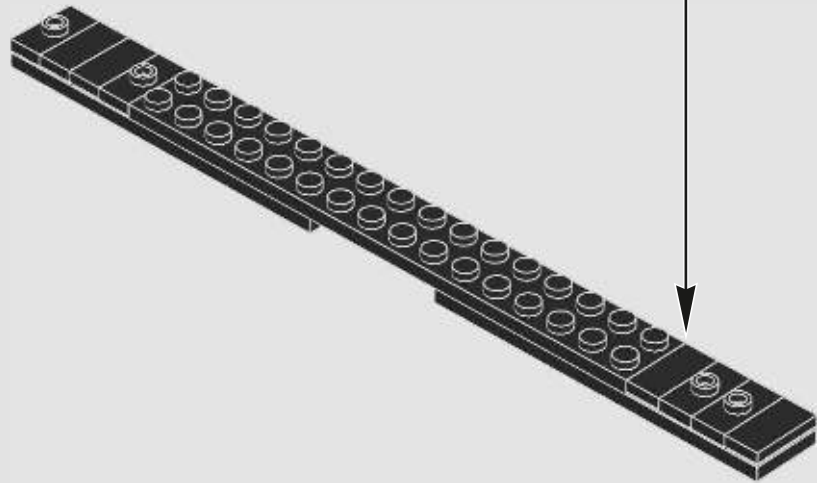
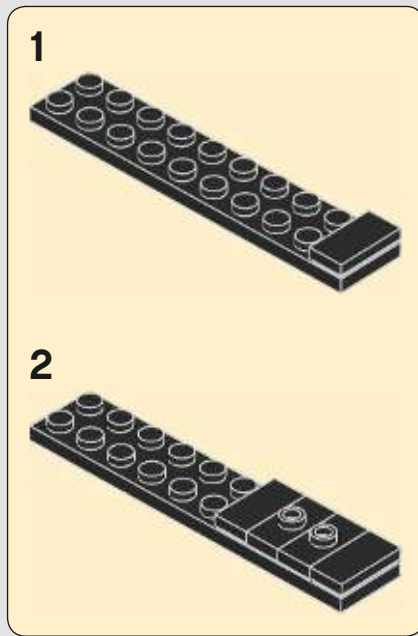

323

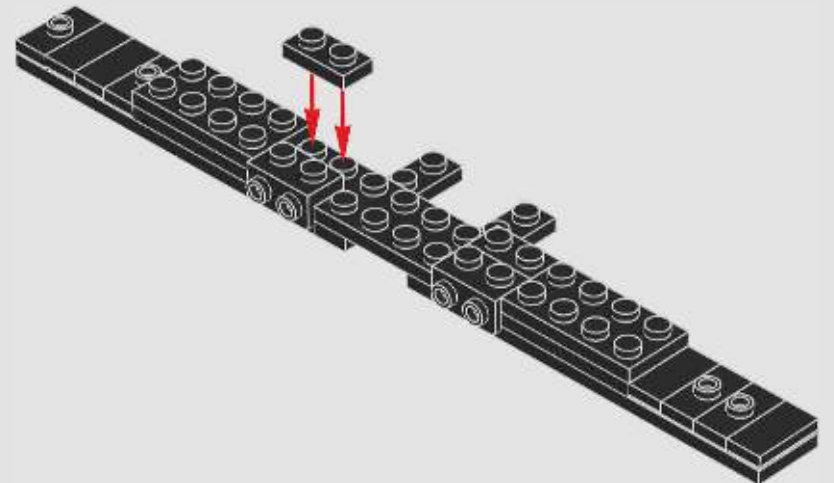



3x

324

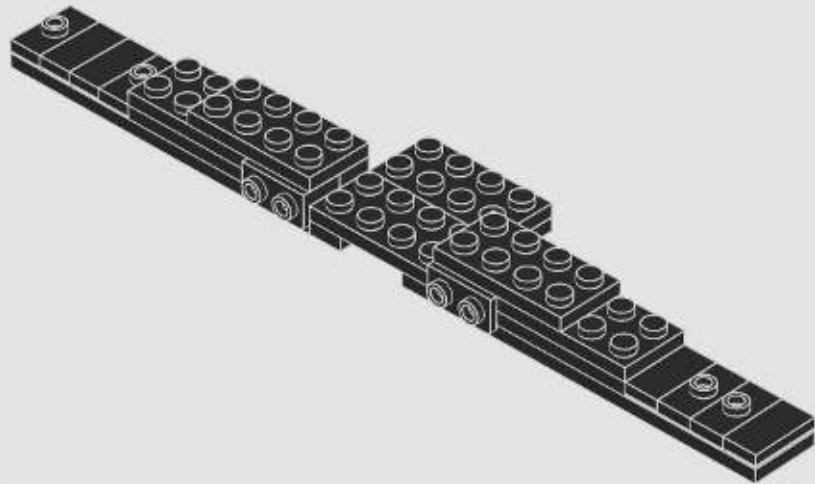

2x



2x

325

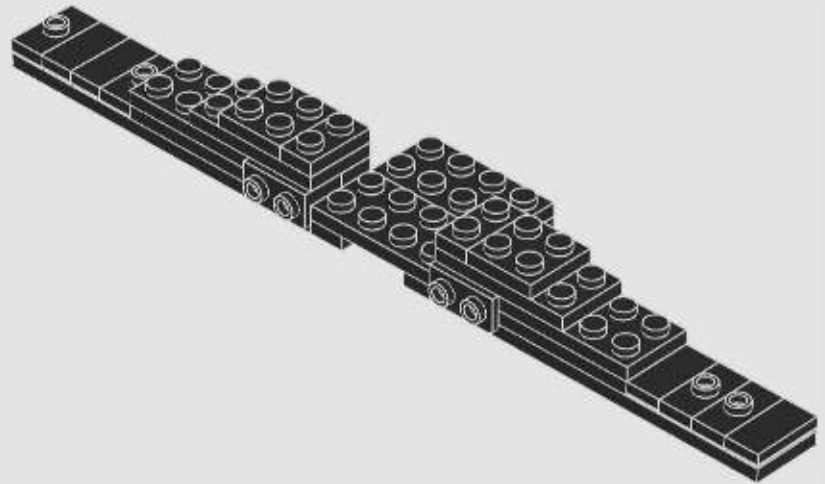



326

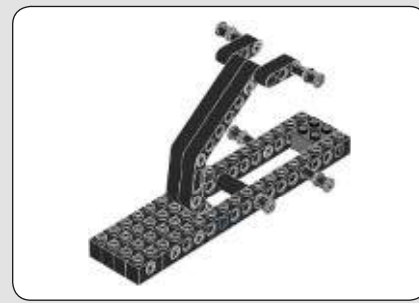
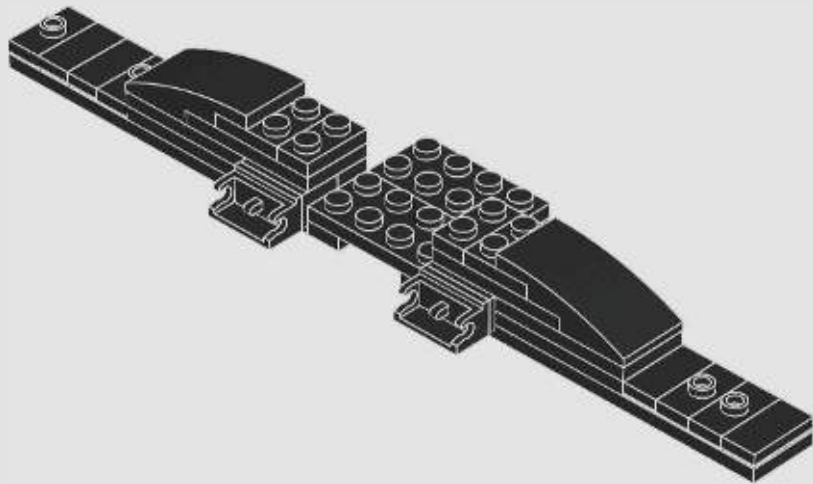

327

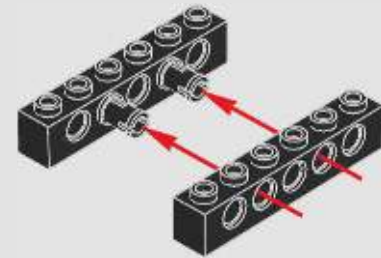



6x

328



2x

329

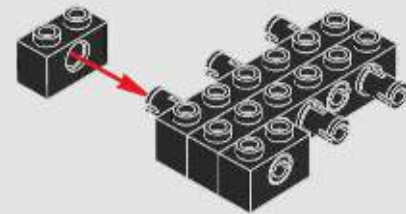

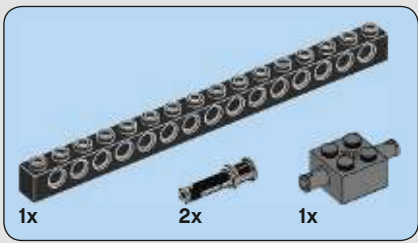

330

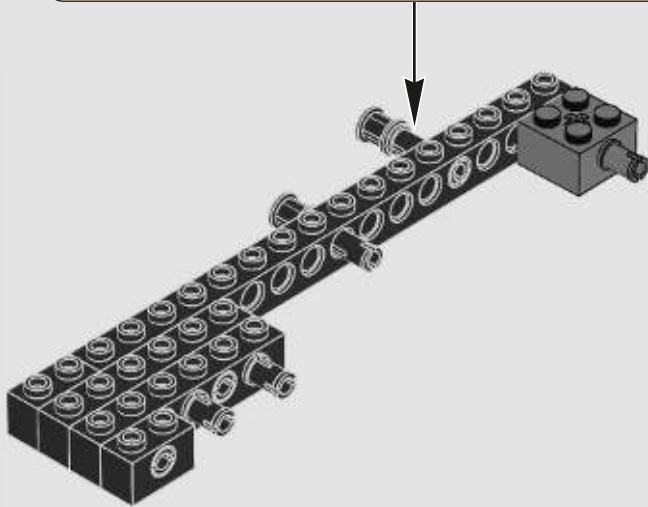
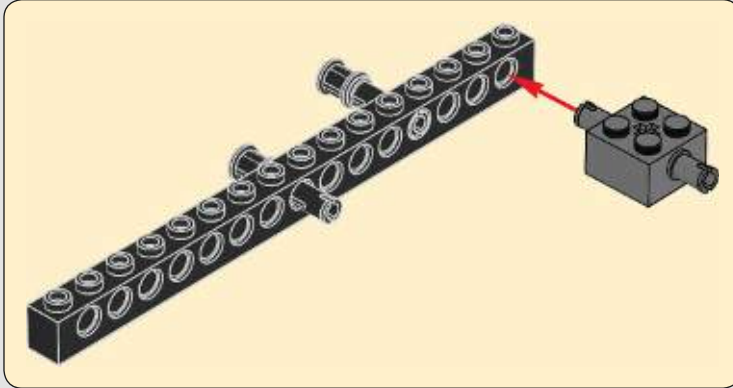

331

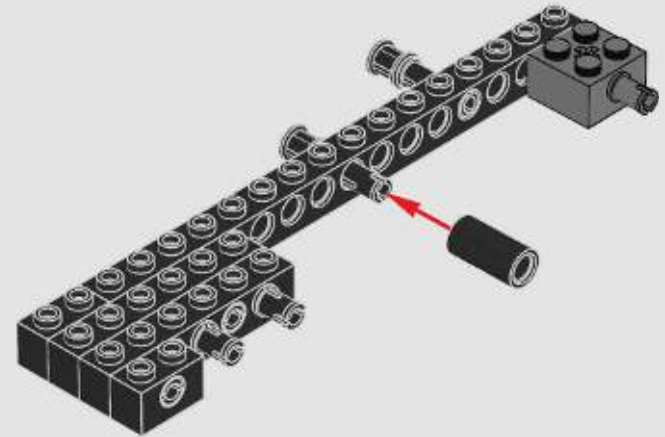

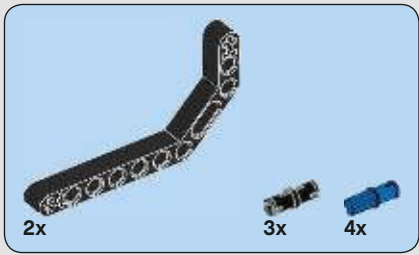

332

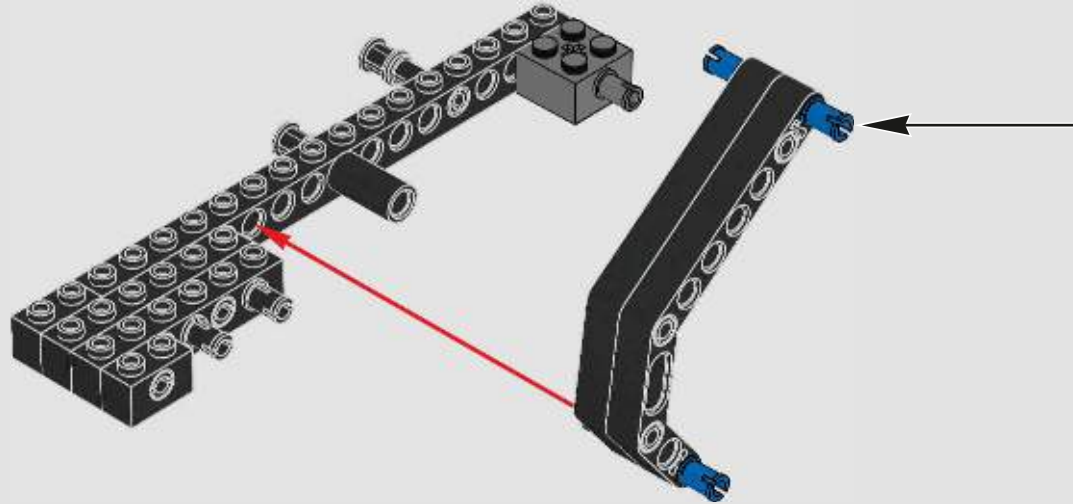
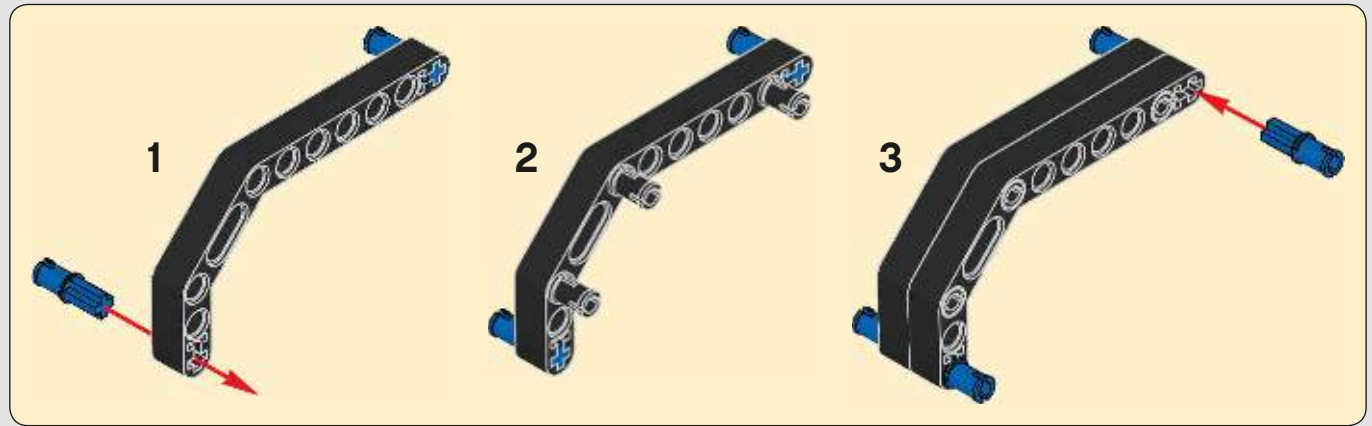

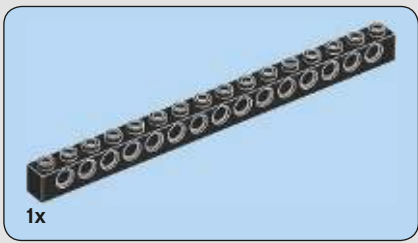

333

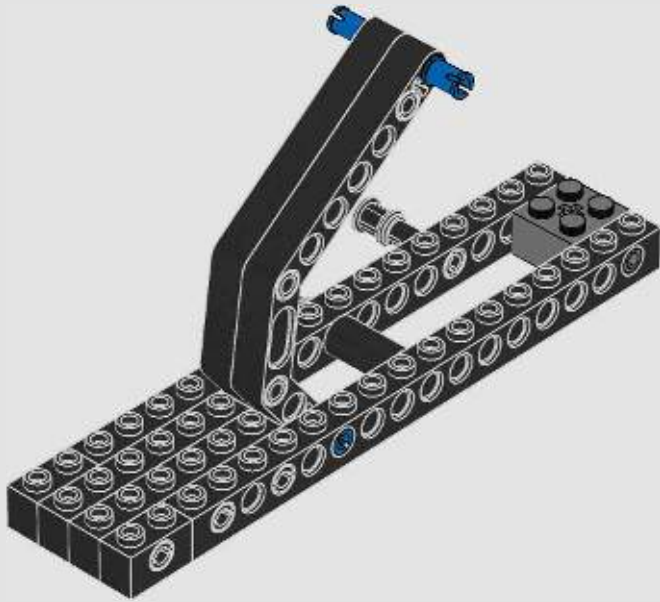

334

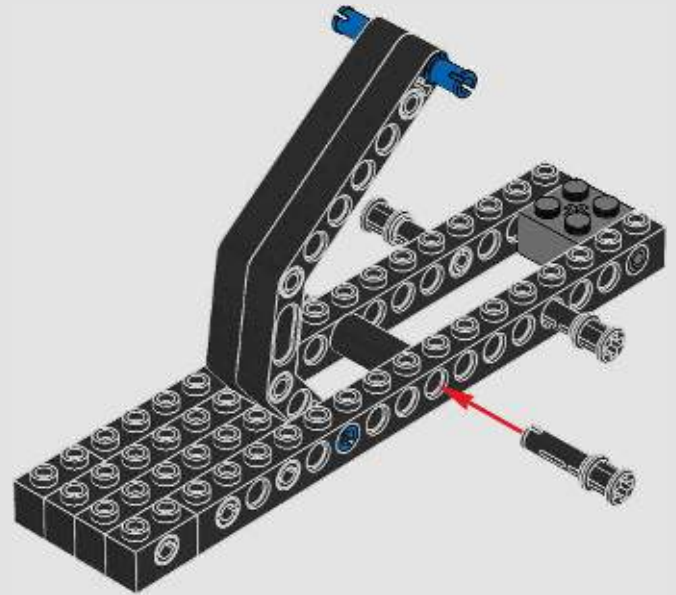



335

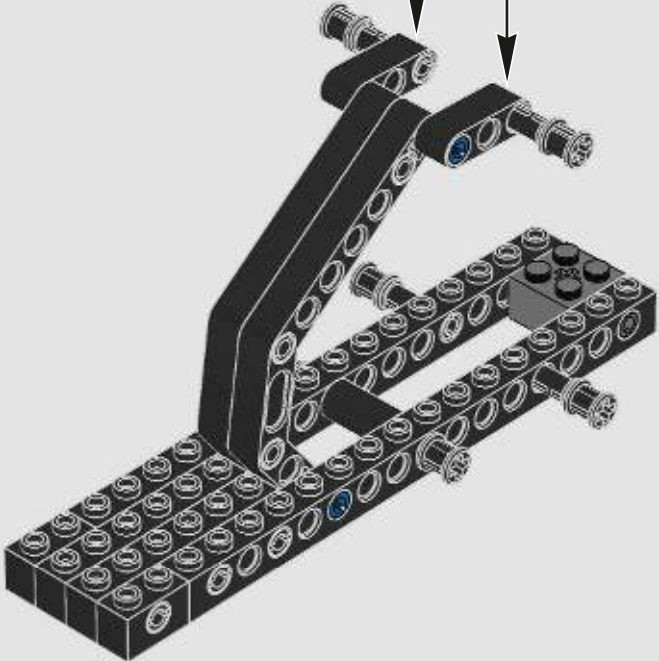
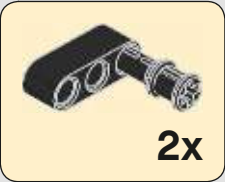

336

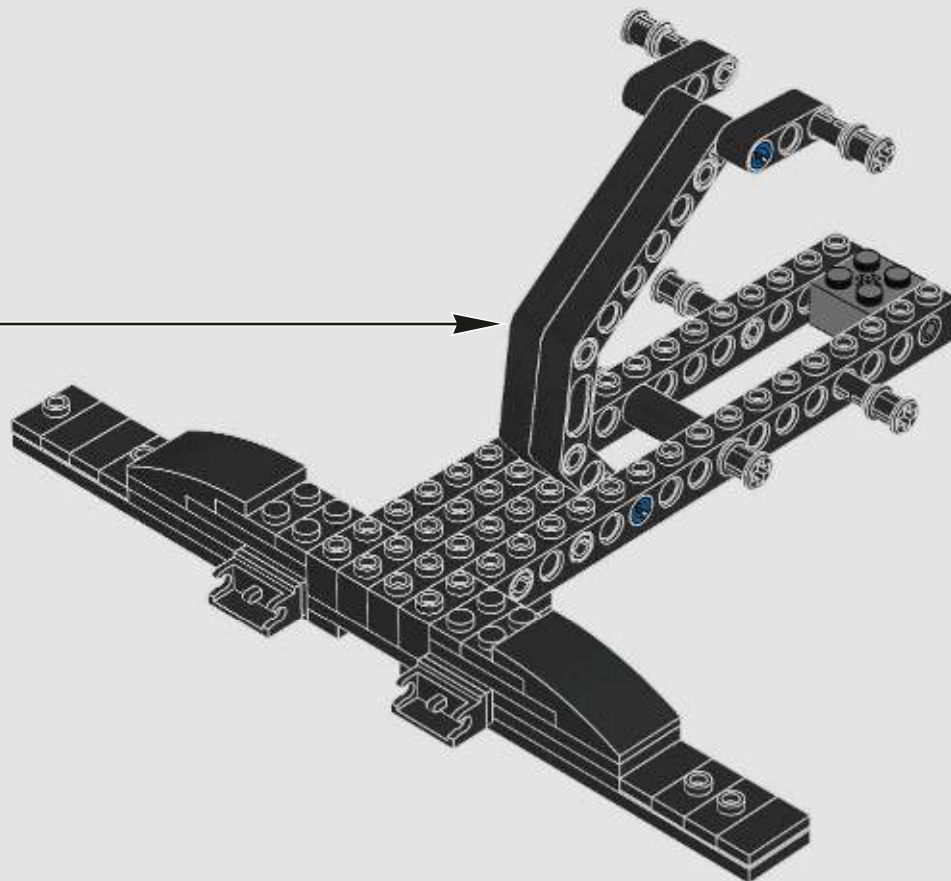

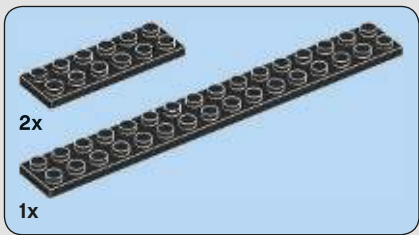

337

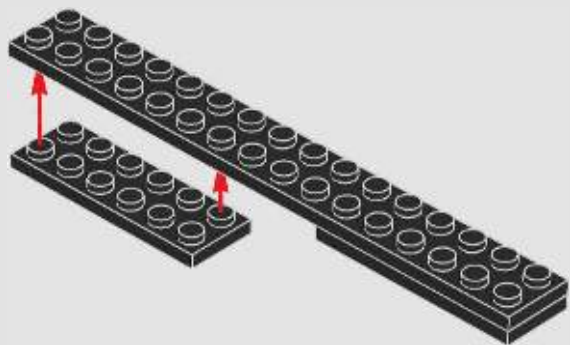

338

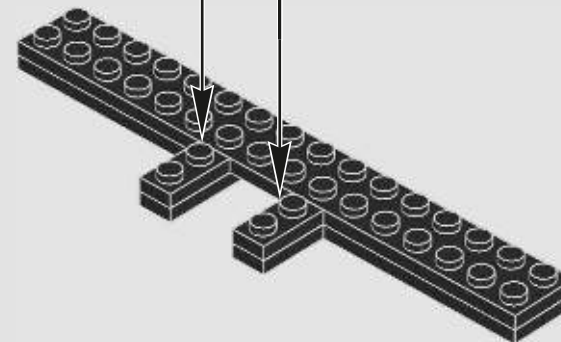
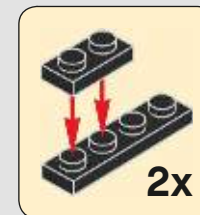

339

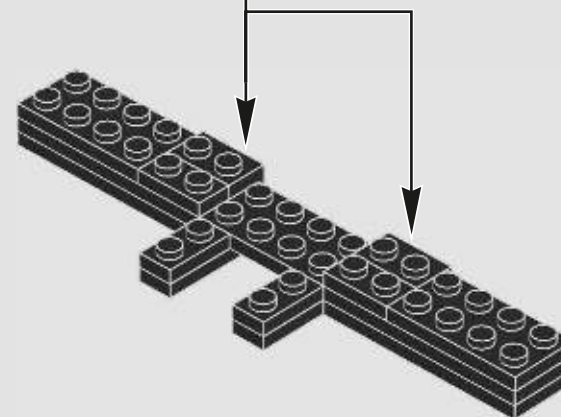



340

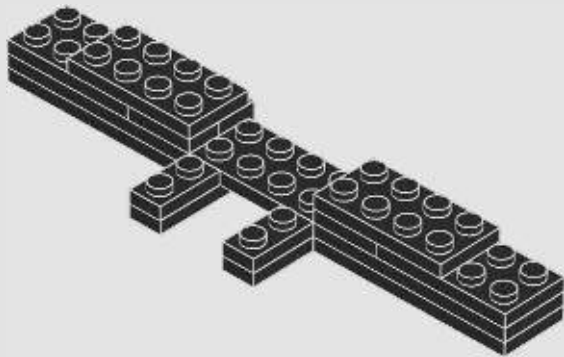

341

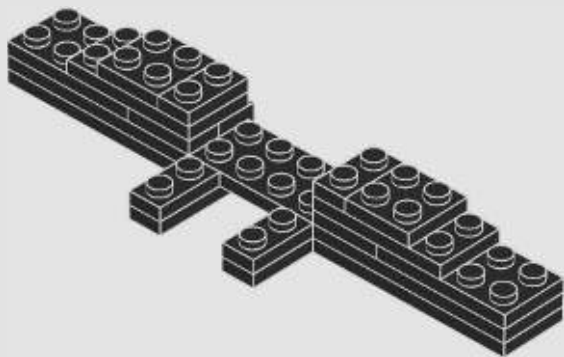

342

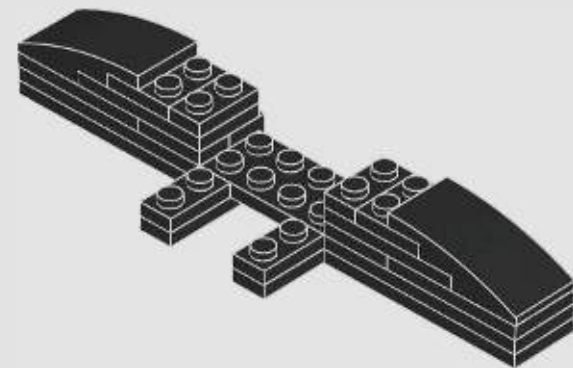

343

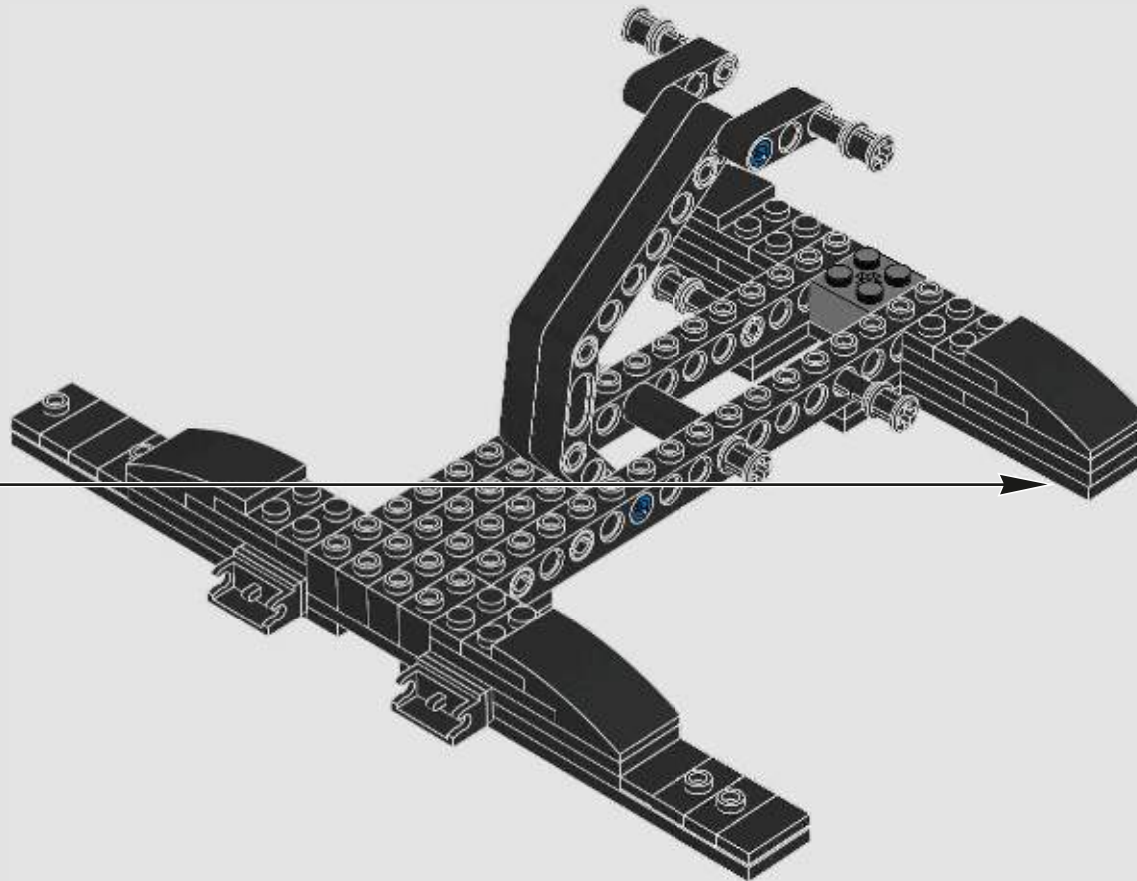



344

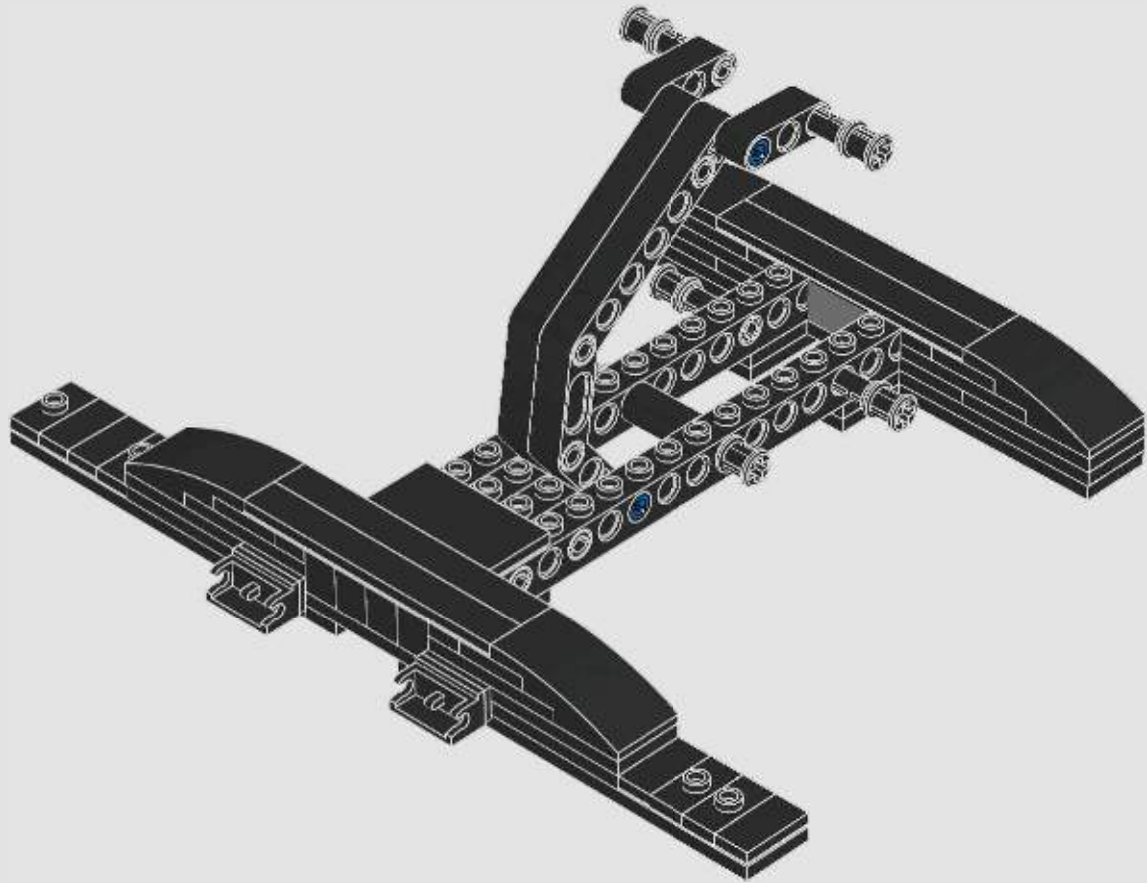

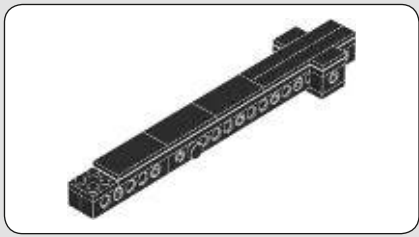

345

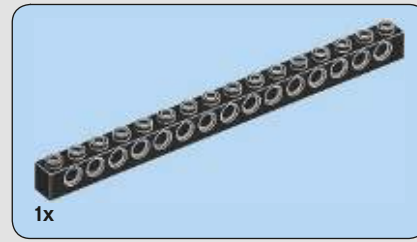
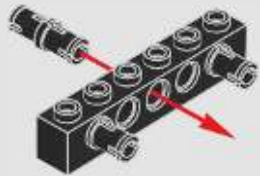

346

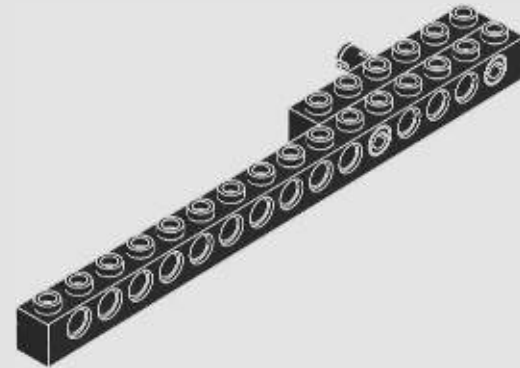



347

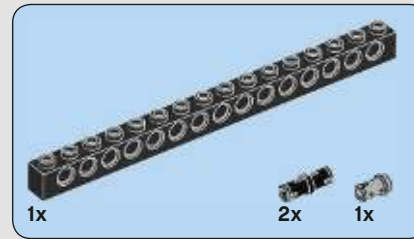
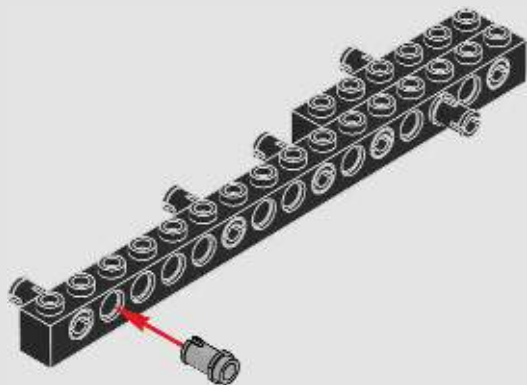

348

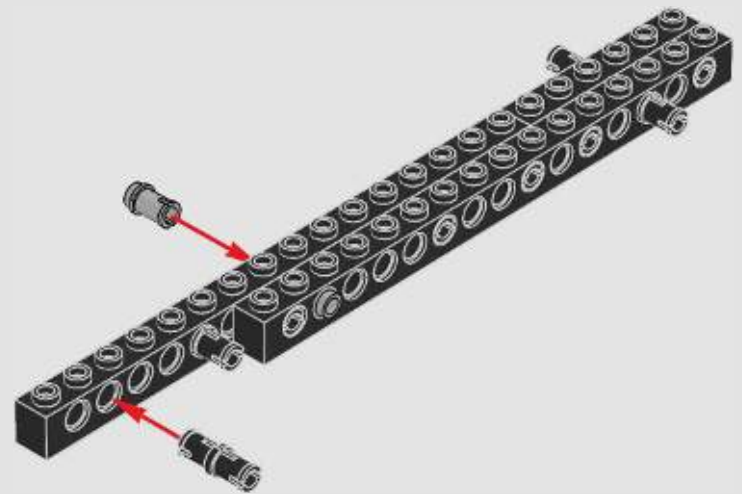

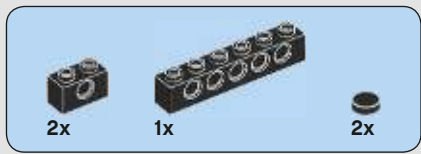

349

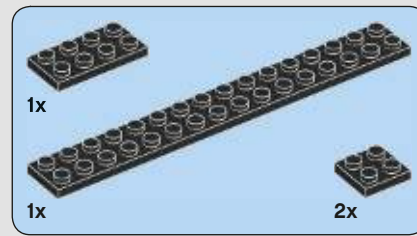
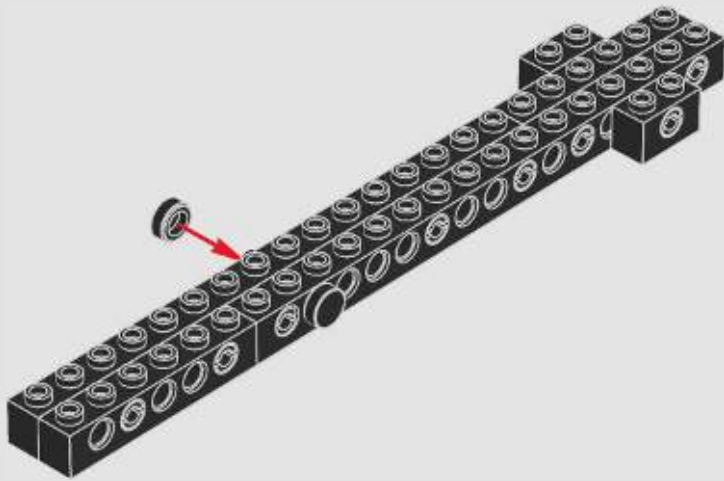

350

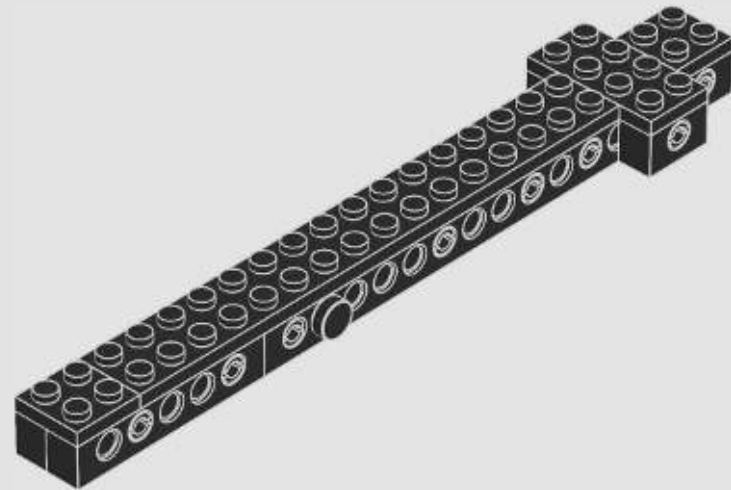



351

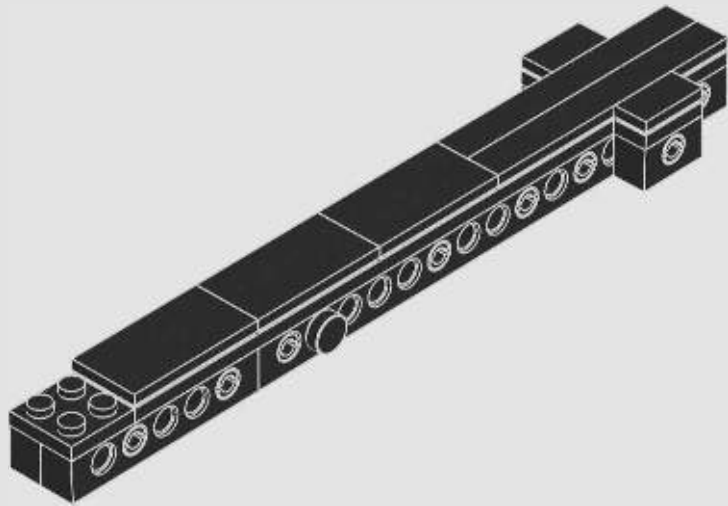

352

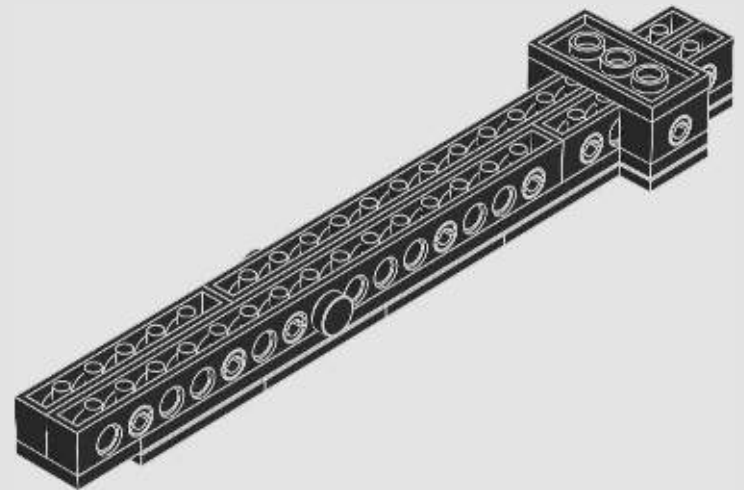
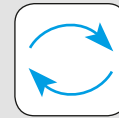

353

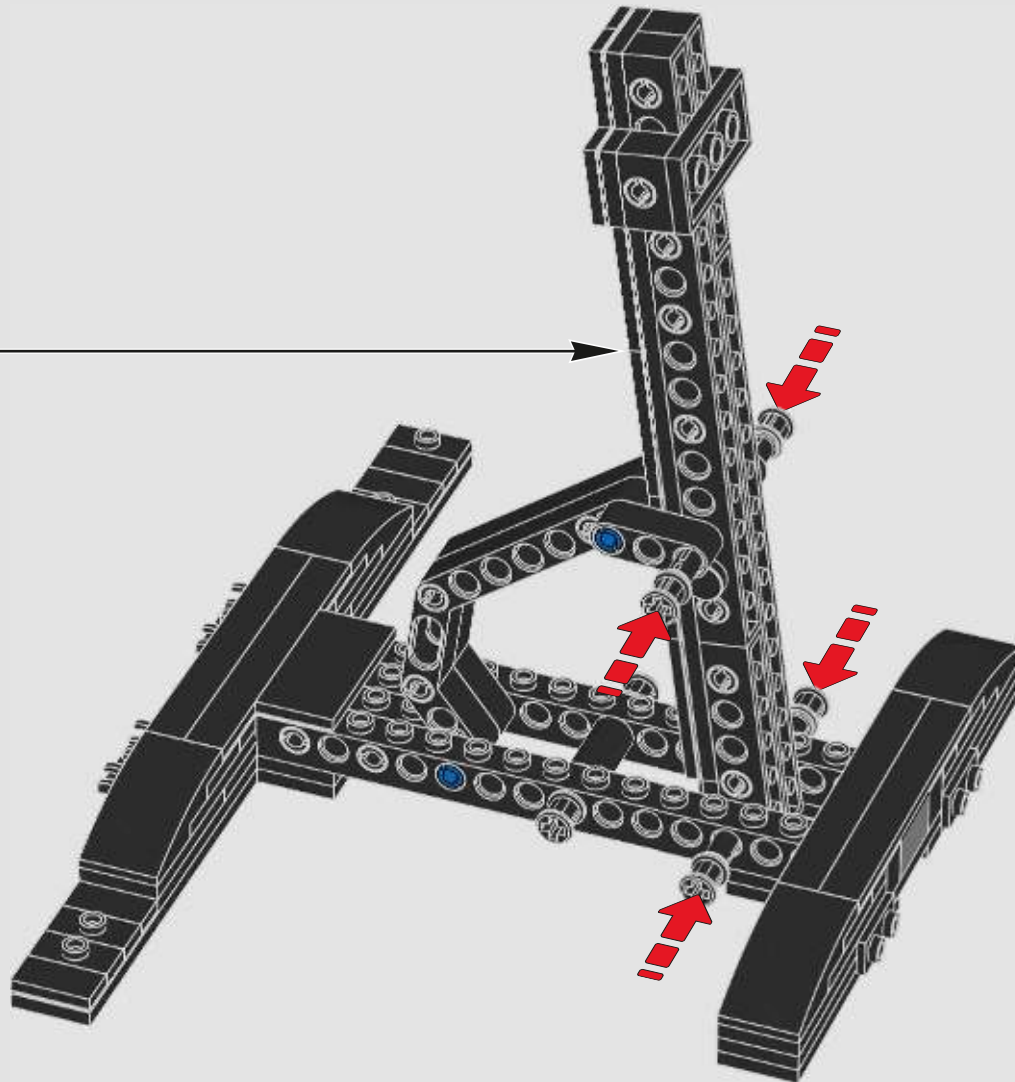

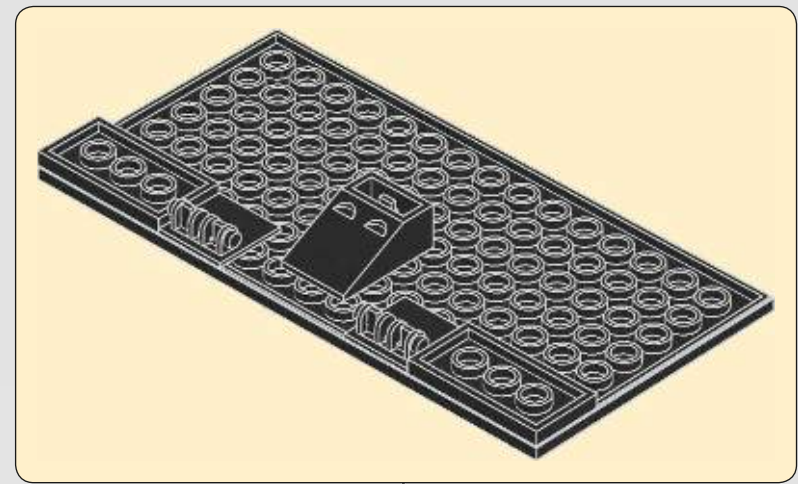
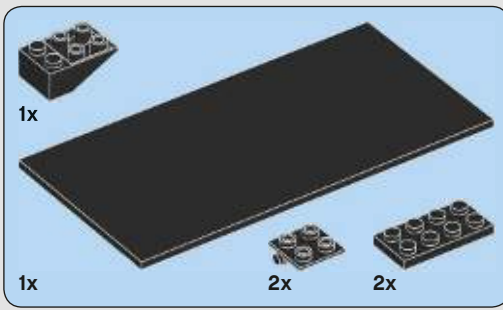

354

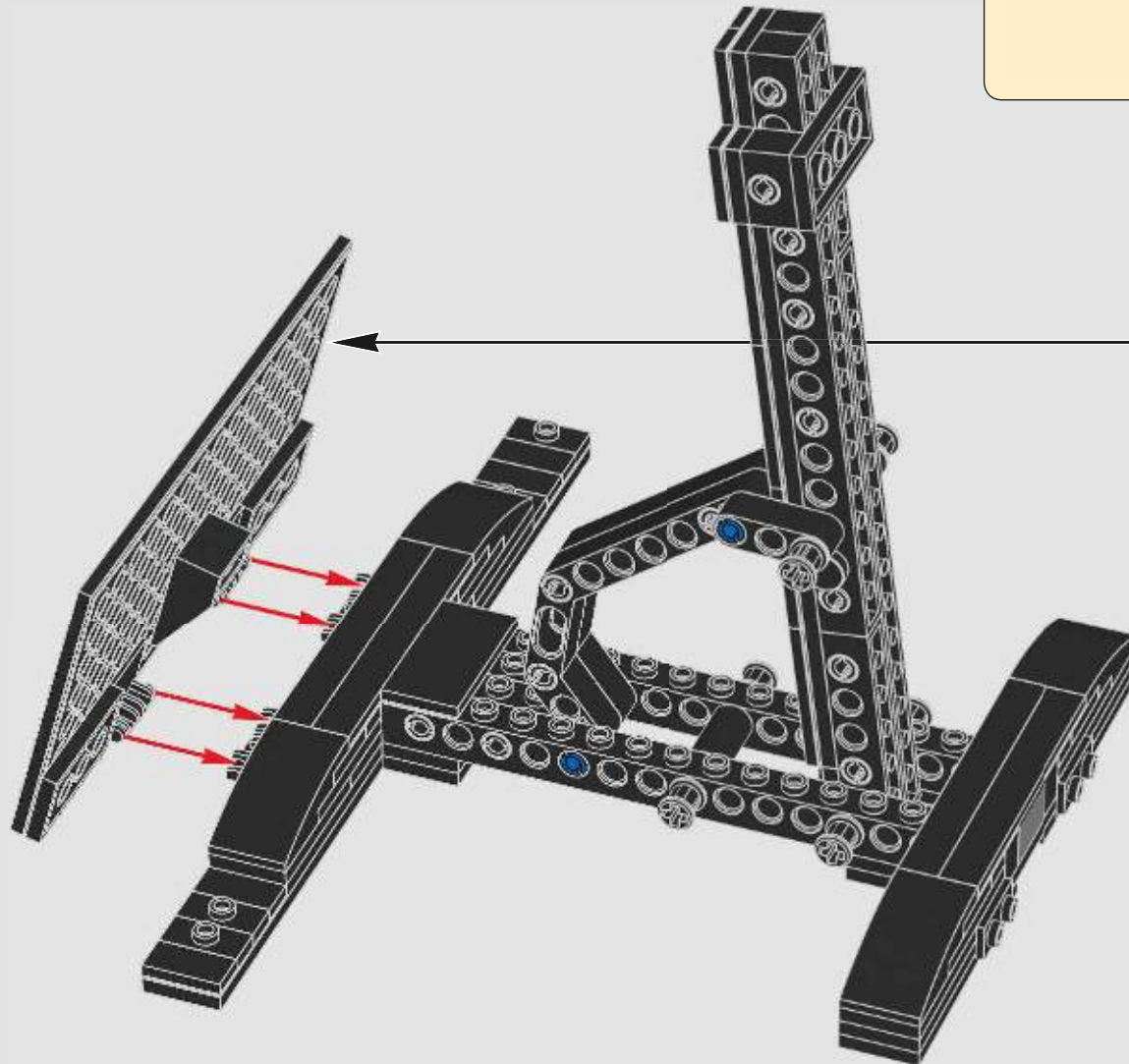

355

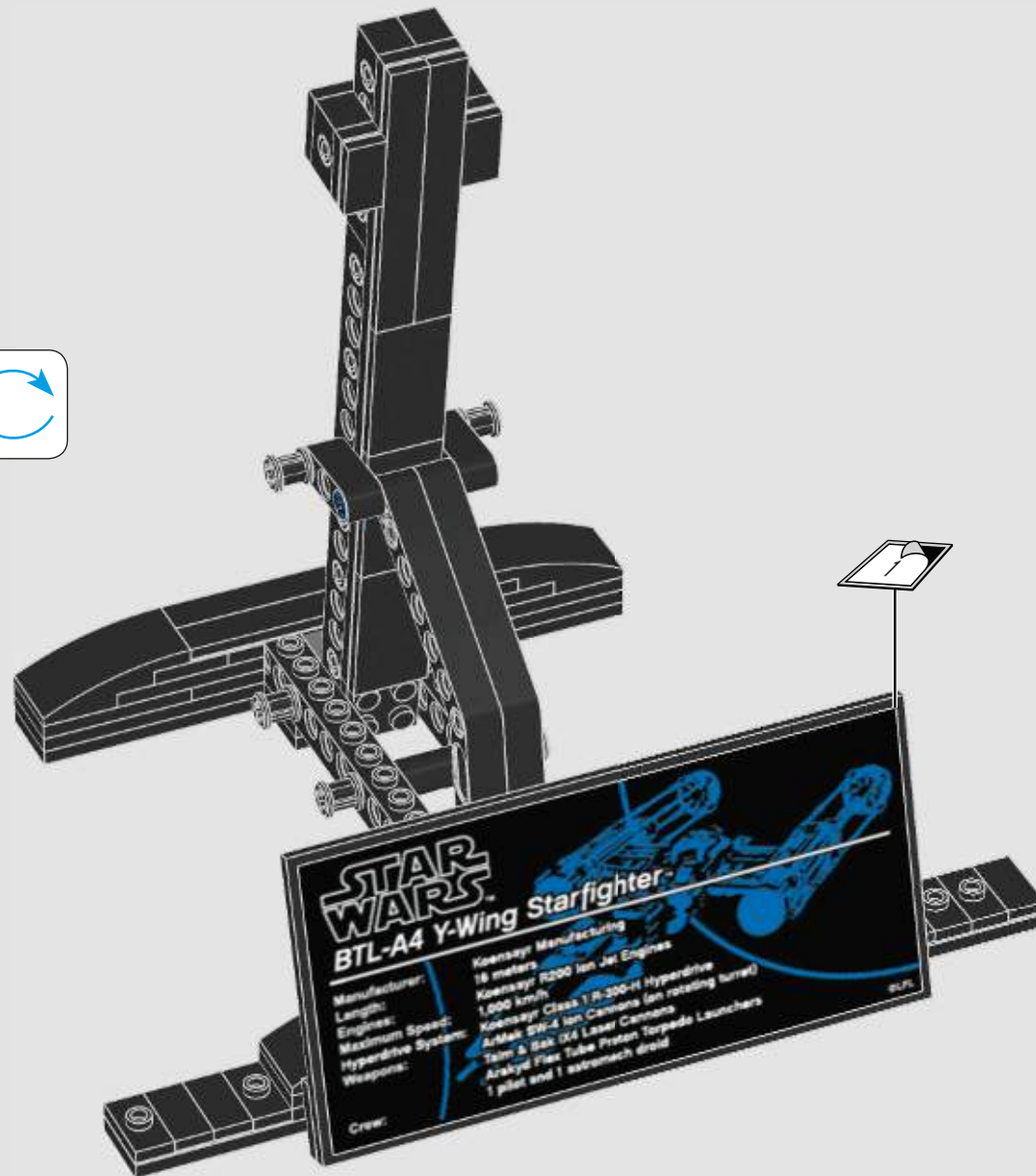
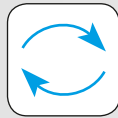

- 6x 302401
- 2x 307001
- 1x 6187547
- 6x 4650644
- 2x 366501
- 1x 306901
- 2x 4611700
- 4x 6023099
- 4x 4140583
- 16x 242001
- 2x 428701
- 2x 362301
- 4x 243101
- 6x 329801
- 2x 4500469
- 4x 4597131
- 2x 6108588
- 218
- 4x 6035405
- 2x 273001
- 2x 6015474
- 2x 6015477
- 2x 303201
- 4x 366601
- 2x 663601
- 2x 6109817
- 2x 379501
- 2x 4179870
- 2x 4261565
- 4x 346001
- 2x 4558168
- 2x 4143000
- 2x 371001
- 8x 4586275
- 2x 6102776
- 2x 302001
- 6x 4118793
- 2x 4565452
- 2x 6175968
- 1x 4140562
- 2x 6214334
- 2x 4185273
- 4x 4114309
- 1x 4179094
- 1x 4179095
- 1x 614324
- 13x 370024
- 4x 6214344
- 2x 300921
- 2x 4143005
- 6x 4206482
- 3x 300423
- 13x 4514553
- 1x 302123
- 10x 302023
- 3x 4239601
- 10x 407024
- 1x 6132609
- 1x 6132201
- 1x 4179094
- 1x 4179095
- 1x 614324
- 13x 370024
- 1x 306824
- 4x 6037676
- 2x 4656699
- 1x 4549896
- 4x 6214348
- 2x 4189400
- 2x 379526
- 3x 346026
- 6x 416226
- 1x 4144025
- 1x 4537551
- 11x 403226
- 44x 4121715
- 4x 6092585
- 30x 302326
- 2x 393726
- 4x 370026
- 6x 306926
- 4x 6016172
- 1x 6011815
- 1x 4140588
- 1x 6093525
- 1x 306826
- 6x 302226
- 4x 242026
- 2x 4124096
- 1x 6089119
- 6x 4140801
- 2x 4142822
- 1x 6015891
- 1x 4609050
- 1x 6121725
- 1x 4609050
- 1x 4603646
- 1x 4550017
- 1x 6173119
- 1x 6056658
- 1x 374726
- 4x 371026
- 4x 4558957
- 4x 4560182
- 13x 302026
- 4x 4647286
- 4x 389426
- 2x 6139403
- 1x 6121725
- 1x 4609050
- 3x 4226179
- 2x 4198311
- 1x 6177804
- 2x 4129859
- 2x 6138232
- 2x 4620077
- 9x 6142505
- 2x 6173163
- 2x 6057880
- 24x 6142245
- 13x 6111685
- 2x 6124349
- 4x 6214347
- 4x 6132790
- 24x 4528604
- 17x 6092591
- 2x 6146234
- 1x 6002849
- 1x 6002851
- 1x 6031821
- 2x 6001822
- 3x 4267874
- 3x 6015424
- 4x 6055172
- 43x 4549436
- 2x 4626884
- 4x 6152107
- 2x 4211412
- 25x 6168647
- 2x 4650260
- 3x 4542590
- 8x 4211573
- 21x 6151688
- 6x 4560175
- 8x 6172538
- 8x 4211567
- 48x 4211483
- 26x 4211476
- 8x 4211399
- 10x 4211622
- 21x 6071229
- 22x 4521921
- 4x 4215513
- 4x 4211535
- 2x 4211760
- 2x 4213567
- 2x 4211758
- 1x 4550170
- 19x 4211508
- 4x 4535764
- 8x 4594238
- 2x 4533772
- 4x 4514195
- 2x 6190437
- 69x 4568637
- 3x 4211475
- 7x 4211807
- 24x 4512360
- 3x 6093859
- 5x 6028812
- 26x 6134378
- 4x 6144138
- 2x 6146223
- 6x 4211398
- 2x 4211437
- 4x 4211440
- 10x 4598526
- 10x 4211469
- 6x 6015344
- 2x 4211519
- 10x 6028813
- 10x 6066097
- 3x 4611702
- 6x 6116608
- 2x 4654580
- 3x 4654582
- 1x 6044729
- 8x 61441609
- 10x 4556157
- 12x 4211568
- 8x 6149991
- 1x 6088708
- 2x 6198932
- 1x 4667578
- 1x 4211632
- 4x 4535738
- 28x 6093527
- 1x 4494222
- 2x 4211862

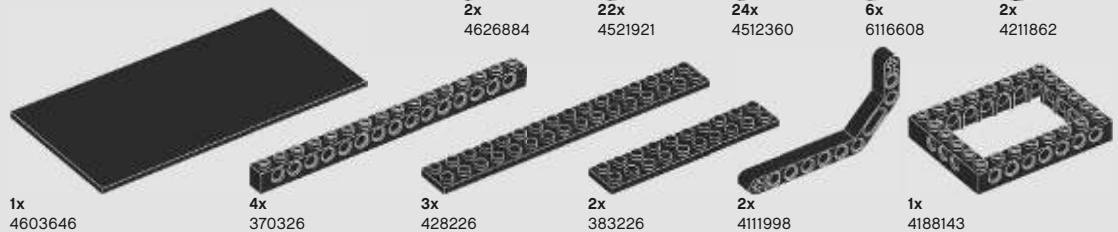

3.2



Customer Service
 Kundenservice
 Service Consommateurs
 Servicio Al Consumidor
 LEGO.com/service or dial
 : 00800 5346 5555
 : 1-800-422-5346



WIN

GO TO WWW.LEGO.COM/PRODUCTFEEDBACK AND
GIVE US YOUR SHORT **FEEDBACK** ABOUT THIS
LEGO® SET FOR A CHANCE TO WIN
A COOL LEGO PRIZE.

Terms & Conditions apply



LEGO.com/productfeedback

GEWINNE

Erzähle uns auf
www.LEGO.com/productfeedback

etwas über die Erfahrungen, die
du mit diesem LEGO® Set gemacht
hast, und sichere dir die Chance
auf einen coolen LEGO Preis!

Es gelten die
Teilnahmebedingungen

GAGNE

Rends-toi sur
www.LEGO.com/productfeedback

et donne-nous quelques com-
mentaires sur ce produit LEGO®
pour avoir une chance de gagner
un prix LEGO !

Voir Conditions Générales

GANANA

Visita
www.LEGO.com/productfeedback

y envíanos tu opinión acerca de
este set LEGO®, ¡Participarás en el
sorteo de un premio LEGO!

Términos y Condiciones aplicables

获取奖品

登录
www.LEGO.com/productfeedback

给出关于此乐高®套装的简短反馈，
就有机会获得炫酷乐高奖品

《条款及条件》适用

경품 당첨 기회

www.LEGO.com/productfeedback

페이지로 이동하여 이 레고® 세트에
대한 간략한 피드백을 보내 주시고
멋진 레고 경품을 탈 수 있는 기회도
잡으십시오

약관 적용

ЗАПОЛНИ АНКЕТУ И ПОЛУЧИ ПРИЗ

Перейди по ссылке
www.LEGO.com/productfeedback

ответь всего на несколько во-
просов об этом наборе LEGO®,
и у тебя появится шанс выиграть
замечательный приз от компании
LEGO.

Применяются Условия и правила
участия