

STAR WARS  
JE VEUX ÊTRE UN JEDI OPUS VII

# VERS TATOOINE ET AU-DELÀ !

SCÉNARIO ET DESSIN : UTTINI





JE VEUX ÊTRE UN JEDI OPUS VII

---

# VERS TATOOINE ET AU-DELÀ !



[WWW.STARWARS-UNIVERSE.COM](http://WWW.STARWARS-UNIVERSE.COM)

## **Avertissement au lecteur :**

Cette bande dessinée est parue à l'origine sous forme de strips de trois cases, ce qui peut expliquer l'aspect «gaufrier» qu'elle a à présent. Les strips n'ont pas été, comme pour les précédents opus, répartis de façon aérée à trois par page, mais à quatre, ce qui permet de faire tenir toute l'histoire dans un format un peu plus compact.

## **Je Veux Être Un Jedi – Opus VII**

Librement inspiré des histoires originales de George Lucas

Textes, dessins et couleurs : Uttini.

Première édition : Juillet 2022

“Star Wars” ainsi que tous ses personnages, noms, lieux, etc... appartiennent à LUCASFILM Ltd. Aucune violation de copyright n'est intentionnelle. Cette oeuvre n'est en aucun cas associée aux propriétaires/créateurs/producteurs/acteurs de l'oeuvre originale, et aucun profit financier n'en est tiré. Ce récit a été créé uniquement par amour du sujet traité et pour le plus grand plaisir des fans.

Remerciements : à tous les membres du staff et tous les forumeurs de Starwars-Universe. A Lamb Bear, à Sky Karrde, à AAARGH pour leurs encouragements, et à George Lucas pour avoir créé cet univers si vaste et si plein de possibilités.

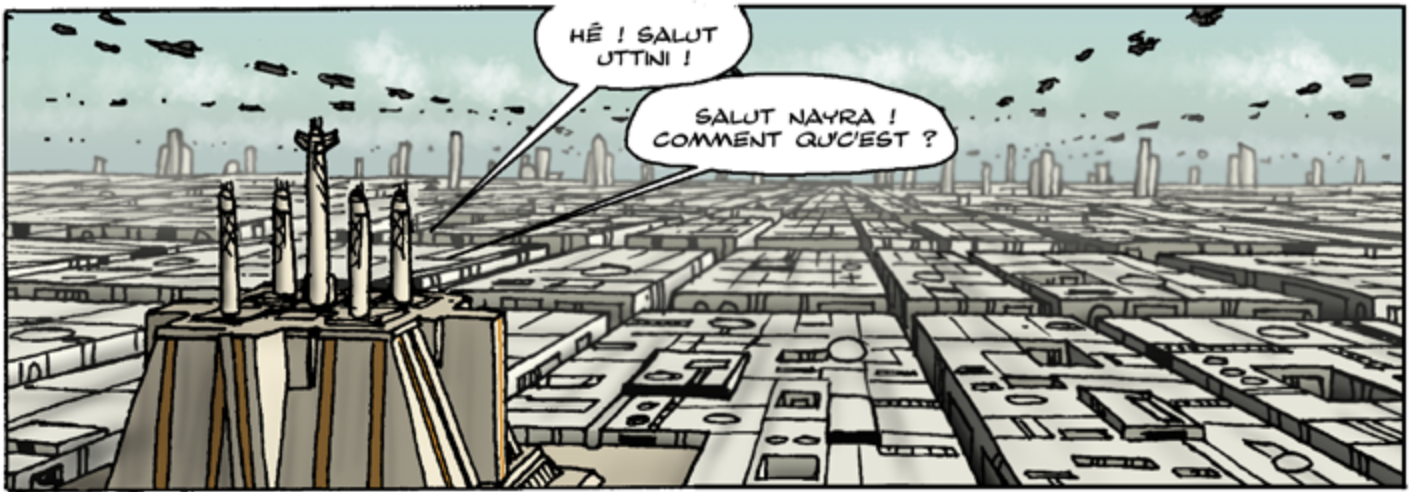

HÉ ! SALUT  
UTTINI !

SALUT NAYRA !  
COMMENT QU'EST ?



TU CONNAIS LA NOUVELLE ? ON  
NOUS A AFFECTÉ À UN MAÎTRE  
ET ON VA PARTIR EN MISSION !

AH OUAIS ?  
COOL !



ON MA AFFECTÉ À MAÎTRE  
SECURA ! COMME ON EST DES  
TWLEKS TOUTES LES DEUX C'EST  
SUPER, NON ? MAIS, ET TOI,  
UTTINI ? TU FAIS QUOI ?

MOI ?  
BIN...



J'FAIS DES MAQUETTES !



MAIS... ILS NE 'ONT PAS AFFECTÉ  
À UN MAÎTRE JEDI, TOI ?

BIN SI ! AVEC  
MAÎTRE YODA !



ET... ON NE T'A PAS CONFIE  
UNE MISSION ? UN TRUC TRÈS  
COMPLIQUÉ, DIFFICILE À FAIRE ?

BIN SI ! BIEN  
SÛR ! UN TRUC  
VRAIMENT TRÈS  
DIFFICILE !



FAIRE DES MAQUETTES DE  
TOUS LES VAISSEAUX DE  
CORUSCANT ! C'EST UN  
SACRÉ BOULOT !



C'EST PAS DE L'ENTRAÎNEMENT  
ÇA ! JE TE PARLE D'UNE VRAIE  
MISSION, PÉRILLEUSE ET TOUT !  
UN VRAI TRUC DE JEDI, QUOI !

SI, C'EST DE  
L'ENTRAÎNEMENT !



JE M'ENTRAÎNE À ASSEMBLER  
LES MAQUETTES AVEC LA FORCE.  
C'EST SUPER DUR ! Y'A PLEIN DE  
TAS DE PTITS MORCEAUX À  
METTRE ENSEMBLE !



SEUL PROBLÈME :  
C'EST PAS TRÈS  
PRATIQUE AVEC  
LA COLLE !



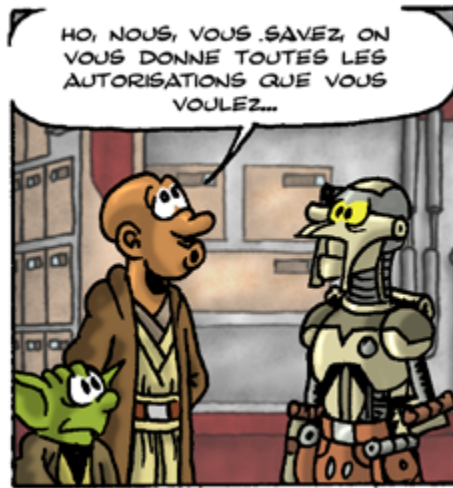





# Histoire remarquable et incroyable des cristaux kyber mutants

Par Maître Huyang, spécialiste galactique incontesté du sabre-laser

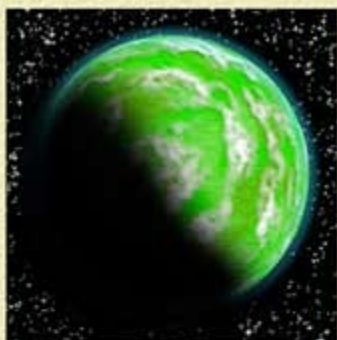

Voilà plus de 400 ans, existait un système appelé Florina. C'était un système sur lequel on trouvait des cristaux kyber d'une grande pureté, des cristaux presque parfaits, très puissants. Il y avait sur ce système un temple Jedi dédié à la Collecte, et des générations de Jedi ont trouvé leurs cristaux dans les grottes lumineuses de Florina.

Mais un jour, on comprit que le soleil de Florina se changeait en nova. La planète allait bientôt être entièrement détruite, désintégrée par l'explosion de son étoile. Le conseil Jedi décida de mettre sur pied une mission spéciale, chargée de recueillir le plus possible de cristaux avant que la planète ne soit carbonisée. Un vaisseau, l'Émissary, fut affrété, doté d'un équipage composé de dix Jedi, et lancé vers Florina.



Le vaisseau arriva à bon port, mais lorsque les Jedi examinèrent les cristaux qu'ils trouvèrent sur la planète, ils firent une découverte stupéfiante : sous l'effet de bouffées de radiations non identifiées émises par l'étoile mourante, les cristaux kyber avaient muté.

Ils s'étaient transformés et avaient acquis des propriétés différentes des cristaux normaux. Les Jedi en firent une description précise, et transmittent des mesures au temple de Coruscant.



C'est alors qu'on perdit tout contact avec le vaisseau Jedi. Toutes les transmissions furent rompues, le vaisseau disparut corps et biens, lui, son équipage et sa précieuse cargaison de cristaux kyber mutants. Personne ne sait ce qu'il est réellement advenu du vaisseau et de son équipage. On suppose qu'il a été détruit dans l'explosion prématurée de l'étoile, avec le système Florina. C'est ainsi qu'aucun cristal mutant n'a jamais pu être examiné depuis, bien qu'une description précise de ceux-ci existe dans les archives Jedi.





L'ÉPAVE DU VAISSEAU EMISSARY L'OBJECTIF EST DE RETROUVER. DE SAVOIR CE QU'EST DEVENU L'ÉQUIPAGE IMPORTANT EST AUSSI ENFIN, IL Y A LA CARGAISON. IL FAUT LA RETROUVER. PRÉCIEUSE ELLE EST !



FACILE ! ON REPÈRE L'ÉPAVE DEPUIS L'ORBITE, ON SE POSE À CÔTÉ, ON EXPLORE ET ON S'EN VÂ. RIEN DE BIEN COMPLIQUÉ.

HO ! J'PARIERAIS PAS LÀ D'SUS, MOI !



TOI, ON T'AS PAS DEMANDÉ TON AVIS. C'EST MOI LE CHEF DE CETTE FICHUE EXPÉDITION ! ALORS PLUS UN MOT !

POU-LÀ-LÀ ! OK ! MOI JE VOULAIS JUSTE AIDER !



VOUS IMAGINEZ SI UN SITH DÉCOUVRIT L'EXISTENCE DE CES CRISTAUX MUTANTS ? ÇA POURRAIT ÊTRE DRAMATIQUE !

HUM... UN GRAND DANGER NOUS POURRIONS TOUS COURIR, OUI...



MAIS PAS D'INQUIÉTUDE À AVOIR ! TRÈS PEU DE GENS AU COURANT SONT DE L'EXISTENCE DES CRISTAUX. ET DES GENS DE CONFIANCE ILS SONT TOUS !

HA BON ?



VOYONS... VOUS ET MOI IL Y A HUYANG, UTTINI, ET AUSSI LE CHANCELIER PALPATINE. MÊME MAÎTRE SECURA AU COURANT N'EST PAS...

HA BIEN ! ME VOILÀ RASSURÉ !



CEPENDANT...

LES JEDI ORGANISENT UNE EXPÉDITION SUR TATOONINE POUR Y RÉCUPÉRER DES ARTÉFACTS PRÉCIEUX, À CE QU'IL SEMBLE. ON NE SAIT PAS DE QUOI IL S'AGIT...



IL FAUT RÉCUPÉRER CES ARTÉFACTS CÔTÉ QUE CÔTÉ. NOTRE MAÎTRE COMPTE SUR NOUS, VENTRESS !

C'EST COMME SI C'ÉTAIT FAIT !



ENFIN, ATTENTION QUAND MÊME, LE JAWA SERA AVEC EUX !

JE L'AI DÉJÀ VAINCU UNE FOIS, JE PEUX LE VAINCRE ENCORE !

SI VOUS LE DITES...



J'AI ENTENDU DIRE QUE LES JAWAS DÉPEÇAIENT LES ÉPAVES. IL NÉ DOIT PAS RESTER GRAND-CHOSE DE L'EMISSARY !

AUCUN RISQUE DE CE CÔTÉ, VU L'ENDROIT OÙ IL S'EST CRASHÉ !



IL EST TOMBÉ TOUT PRÈS DU PÔLE SUD, À DES MILLIERS DE KILOMÈTRES DE LA VILLE LA PLUS PROCHE... ET PERSONNE NÉ VA JAMAIS AU PÔLE SUD.

HA BON ?



HÉ HÉ ! UN ÉPAVE QUE LES JAWAS NE PEUVENT PAS PILLER, ÇA DOIT ÊTRE FRUSTRANT, ÇA !

T'AS TOUJOURS LA LANGUE AUSSI BIEN PENDUE, TOI...

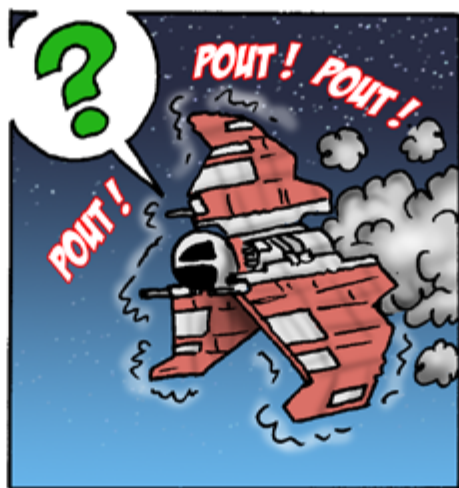



ON EST SAUVÉ ! ON NE TOMBE PLUS ! QUELLE FRAYEUR !



MAIS TU SAVAIS BIEN CE QUI ALLAIT SE PASSER, AVOUE !

BIN OUAIS !



ET POURQUOI T'AS RIEN DIT AVANT, ESPÈCE D'AVORTON ?

CHAIS PAS. COMME ÇA, J'AI VOULU VOIR.



MAINTENANT TU PEUX EXPLIQUER CE QUI S'EST PASSÉ ?

IL Y A UNE ANOMALIE AU PÔLE SUD DE TATOONIE. TOUS LES TRUCS ÉLECTRONIQUES TOMBENT EN PANNE QUAND ON S'EN APPROCHE.



ET BIEN SÛR, ELLE NE FIGURE SUR AUCUNE CARTE STANDARD TON ANOMALIE ?

PARCE-QUE TOUT LE MONDE S'EN MOQUE. Y'A QUE DU DÉSERT AU PÔLE SUD...



ET ELLE S'ÉTEND LOIN, CETTE ANOMALIE, AUTOUR DU PÔLE ?

BAH... DISONS 1000 KILOMÈTRES DANS TOUTES LES DIRECTIONS !



1000 KILOMÈTRES ? ON PEUT FAIRE ÇA À PIEDS ! ON EST DES JEDI, LA FORCE EST AVEC NOUS !

BIN MOI, J'PARIERAIS PAS LÀ D'SUS !



MAIS ENFIN, QUI C'EST QUI COMMANDE ICI ? ON NE T'AS PAS DEMANDÉ...

HEUUUU...



OUI... BON... QU'EST-CE QUE TU DISAIS ?



AU PÔLE SUD DE TATOONIE, LA TEMPÉRATURE EN PLEIN JOUR EST INSUPPORTABLE ! ON NE PEUT PAS Y ALLER À PIEDS.

PAS GRAVE. ON MARCHERA LA NUIT !



EN CETTE SAISON, C'EST L'ÉTÉ POLAIRE. LA NUIT DURE TROIS HEURES. ET LE JOUR TRENTE ET UNE HEURES. TOUJOURS PARTANTE ?

HEUU...



BON, ALORS QU'EST-CE QU'ON FAIT DANS CETTE SITUATION ?

EST-CE QUE JE SAIS ! C'EST TOI QUI COMMANDE, NON ?

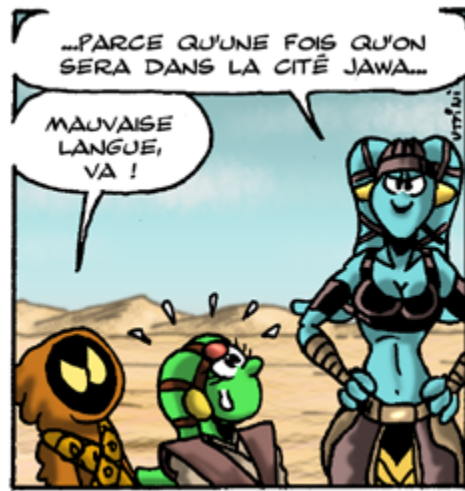

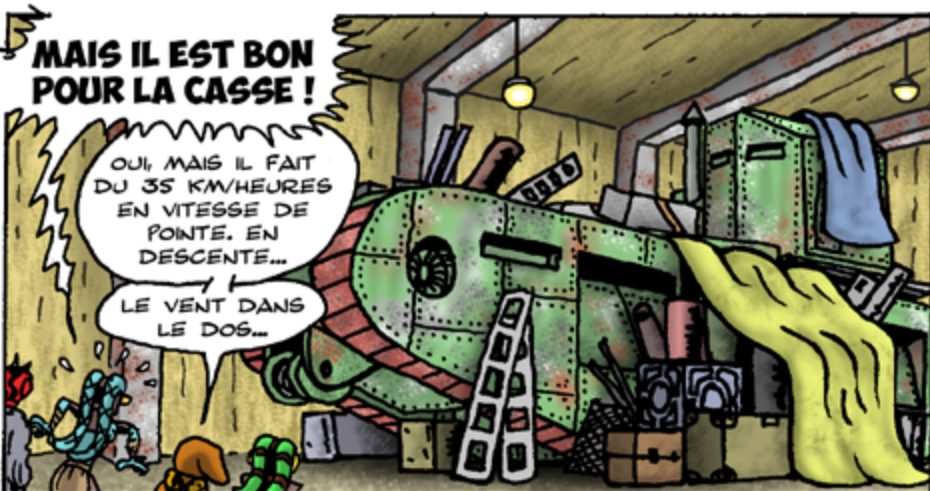

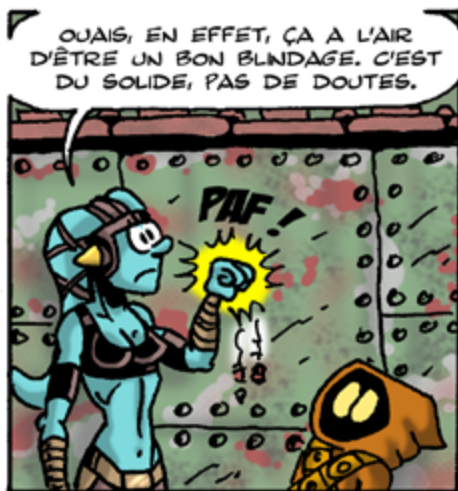





TU PEUX PAS RESTER HABILÉE  
COMME ÇA POUR ALLER AU PÔLE  
SUD ! IL TE FAUT UNE TENUE À  
LA MODE JAWA !

ESSAYE  
ÇA !



BLEEHH ! C'EST QUOI CETTE  
LOQUE ? C'EST IMMONDE ! ET  
ÇA PUE CARNAGE ! JAMAIS  
JE METTRAI UN  
TRUC COMME  
ÇA !



DIS, ÇA FAIT QUOI COMME  
COULEUR UN SUPER COUP DE  
SOLEIL SUR UNE PEAU BLEUE ?



HA BIEN ! VOUS AVEZ RÉCUPÉRÉ  
VOS AFFAIRES DANS LA NAVETTE.

ON VA POUVOIR Y  
ALLER, LE CHAR  
EST FIN PRÊT !



HEIN ? VOUS AVEZ DÉJÀ NETTOYÉ  
TOUT LE CHAR ? AUSSI VITE ?

NETTOYÉ ? POUR  
QUOI FAIRE ? ÇA  
PREND TROP DE  
TEMPS !



NAAN ! ON A APPLIQUÉ LA  
MÉTHODE JAWA : "PEINTURE SUR  
CRASSE ÉGALE PROPRE" ! ON A  
TOUT RÉPENT !  
INTÉRIEUR ET  
EXTÉRIEUR !



C'EST TRÈS...  
ORANGE !

BIN C'EST  
L'ORANGE  
STANDARD DES  
SANDCRAWLERS.



TU VOIS, LE GRAND AVANTAGE  
DE CETTE COULEUR C'EST QUE  
LA ROUILLE SE VOIT MOINS !

TU M'EN DIRAS TANT...



T'ES VRAIMENT SÛR QUE CE CHAR  
NE CRAINT PAS L'ANOMALIE ?

AUCUN RISQUE ! IL N'Y A  
PAS D'ÉLECTRONIQUE À  
BORD, RIEN QUE DU  
MÉCANIQUE, ET  
UN MOTEUR À  
EXPLOSION !



SANS ÉLECTRONIQUE, ON FERA  
COMMENT POUR LES CARTES ?

PAS DE PROBLÈME !  
NOUS LES JAWAS, ON A  
TOUTES LES CARTES  
SUR PAPIER !



MAIS T'AS RÉPONSE À TOUT, TOI !  
ET POUR LE CARBURANT, HEIN ?

PAS DE PROBLÈME !  
DISTILLATION LOCALE.  
TU VEUX GOÛTER ?

DESCRIPTIF DU CHAR  
DE PROSPECTION  
JAWA MARK V

PLATEFORME DE  
STOCKAGE  
EXTÉRIEUR

TREUIL

POSTE DE PILOTAGE  
SALLE DE COMMANDE

COMPARTIMENT  
RÉFRIGÉRÉ

SALLE DE  
RÉPOS  
(COUCHETTES)

STOCKAGE

SALLE DES  
MOTEURS

ÉCHELLE  
D'ACCÈS

RÉSERVOIR  
DE CARBURANT

TRAITEMENT  
D'AIR

CLIMATISATION

GROUPE DE  
FROID

SYSTÈME DE  
RECYCLAGE  
D'EAU

BATTERIES

CABINE ZONE  
DE VIE

RÉSERVOIRS  
D'EAU

SORTIE  
NIVEAU HAUT

PASSERELLE

CABINE  
ZONE DE  
VIE

CLIMATISATION  
TRAITEMENT  
D'AIR

RÉSERVOIR  
DE CARBURANT

POSTE DE  
PILOTAGE

CONSOLE  
TECHNIQUE

RÉSERVOIRS  
D'EAU

GAINÉ  
TECHNIQUE

ACCÈS  
PRINCIPAL

GÉNÉRATRICE  
ÉLECTRIQUE

BLOC MOTEUR  
PRINCIPAL

ARBRE DE  
TRANSMISSION

DIFFÉRENTIEL

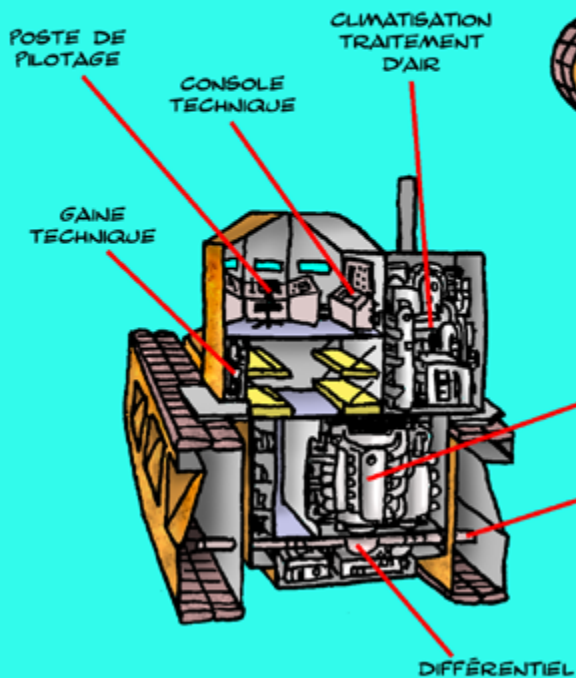
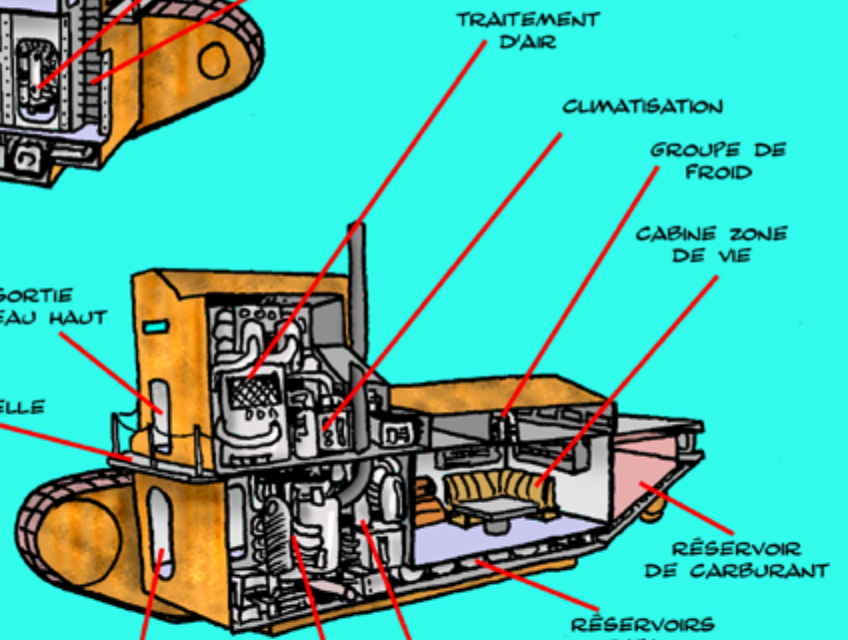
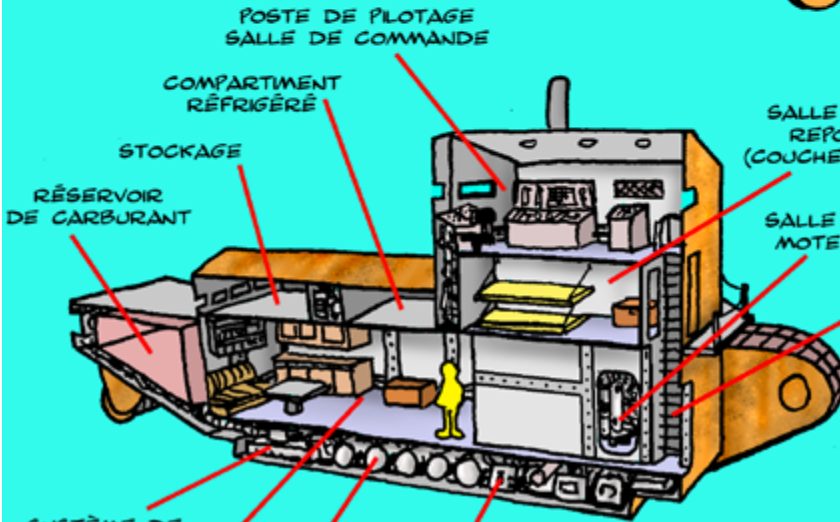
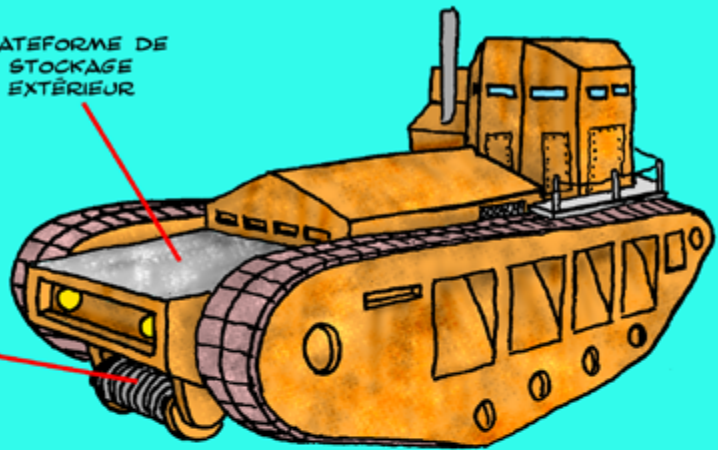







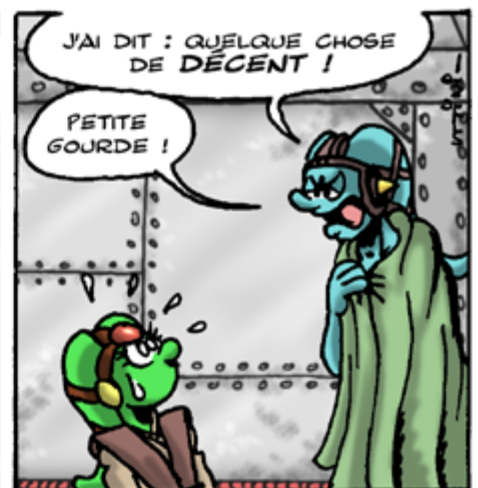

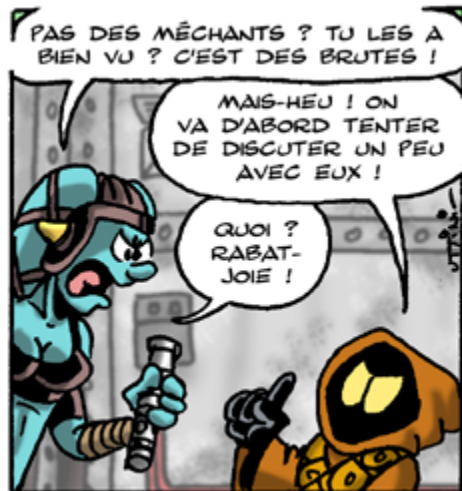





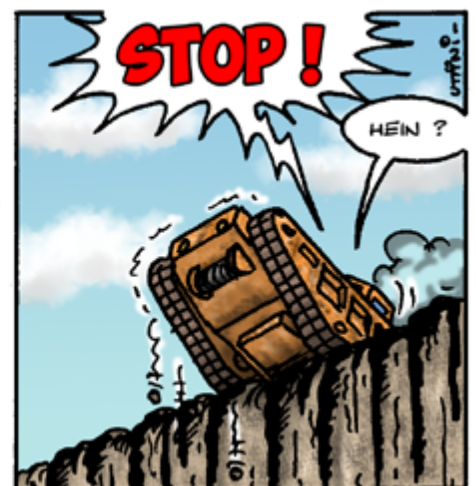



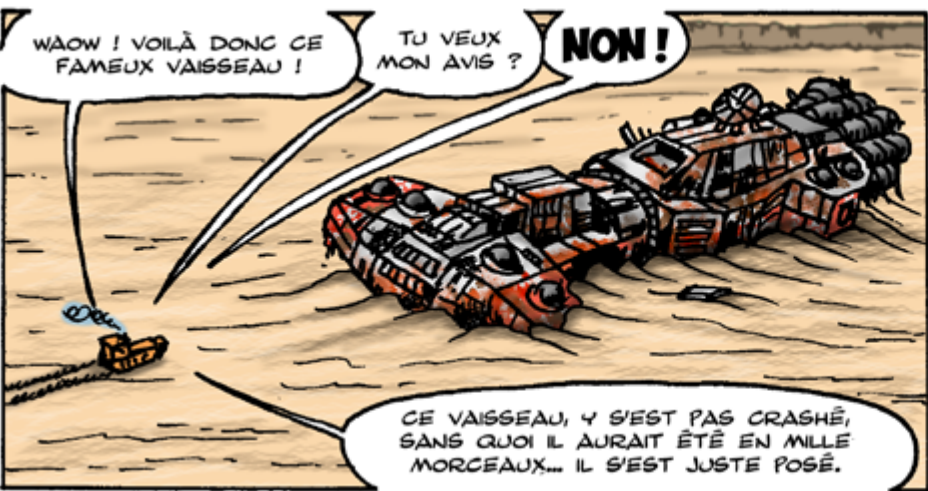



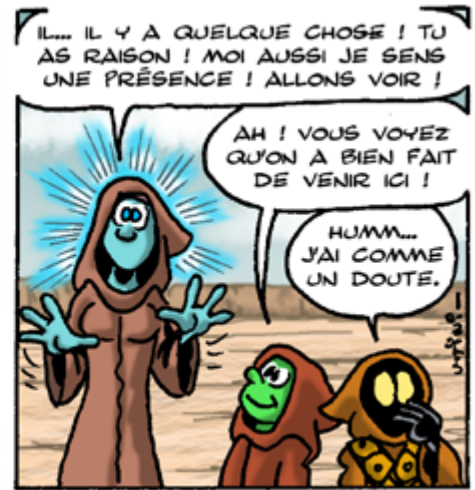









L'ÉMISSAIRE AVAIT QUITTÉ FLORINA QUELQUES MINUTES SEULEMENT AVANT QUE L'ÉTOILE N'EXPLOSE...



MAIS LE VAISSEAU ÉTAIT TRÈS ENDOMMAGÉ...

CAPITAINE ! ON EST PARTI JUSTE AVANT L'EXPLOSION, MAIS LE VAISSEAU EST TRÈS ENDOMMAGÉ !



JE SAIS, C'EST MARQUÉ DANS LA CASE PRÉCÉDENTE.

HUM... ET ON NE PEUT PLUS FAIRE QU'UN SEUL SAUT HYPERSPATIAL, ET TRÈS COURT... JE CROIS QUE J'AI UNE IDÉE. ALLONS VOIR SUR LA PASSERELLE !



UNE FOIS SUR LA PASSERELLE...

TATOONE ? VOUS VOULEZ NOUS EMMENER SUR CE SYSTÈME AUX MAINS DES HUTTS ? POUR QUOI FAIRE ?

CE SYSTÈME A UN ATOUT QUI NOUS SERA PRÉCIEUX !



IL Y A UN TEMPLE JEDI SUR CE SYSTÈME PERDU.

JAMAIS ENTENDU PARLER DE ÇA !

NORMAL. C'EST GARDÉ SECRET DEPUIS DES SIÈCLES.



ET C'EST AINSI QUE...

TATOONE ! ON Y EST !



CAPITAINE ! LES SYSTÈMES DU VAISSEAU TOMBENT EN PANNE LES UNS APRÈS LES AUTRES !

C'EST L'ANOMALIE DU PÔLE SUD. MAIS IL FAUT SE POSER LÀ !



NOUS ALLONS DEVOIR UTILISER LA FORCE AFIN DE PORTER LE VAISSEAU JUSQU'AU SOL.

MAIS... C'EST BIEN TROP GROS !

LA TAILLE NE COMPTE PAS ! EST-CE PAR LA TAILLE QUE TU ME JUGES ?



ÇA NE SERA PAS FACILE, MAIS ON PEUT LE FAIRE. LA FORCE EST TRÈS PUISSANTE EN CHACUN DE NOUS.

ALLONS-Y !



"QUE TOUT LE MONDE SE CONCENTRE..."

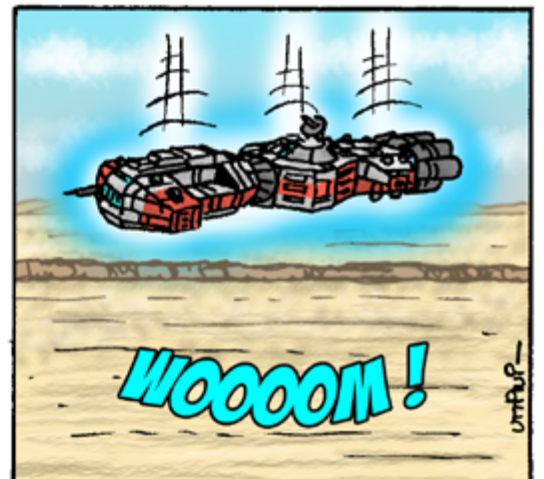





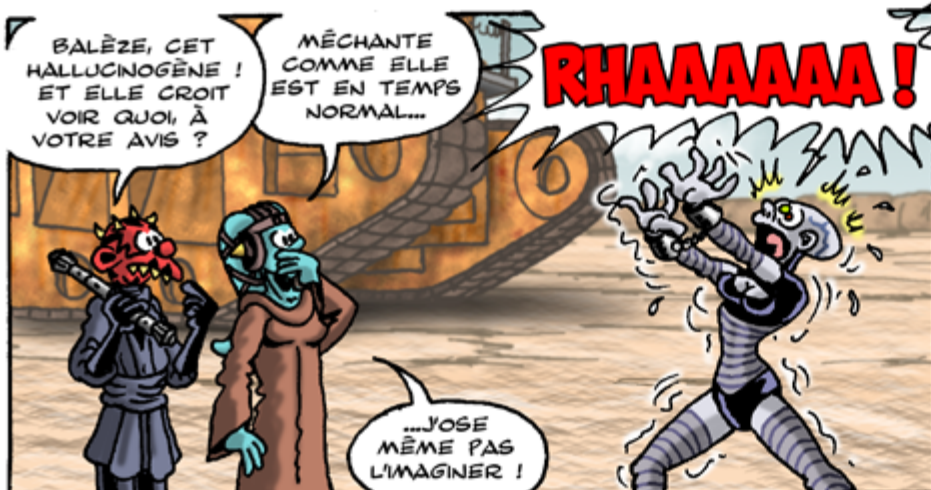



# La porte des Anciens

légende jawa



Il y a bien longtemps, alors que les jawa étaient encore les esclaves des kltkltkts, naquit un jawa pas comme les autres. Son nom était Prui'chathchidt'klavovekth, que nous appellerons pour le conte simplement Klavo. Il faisait partie du clan de la grande vallée polaire du Nord, et il se préparait à prendre la relève de son père comme contremaître de troisième niveau à bord du char des sables du clan.



A cette même époque, Hiwitoe'Echiaqik, la reine-mère de la trente-deuxième descendance, prenant conscience que sa Toute-Fin (le moment où elle ne pourrait plus pondre) approchait, décida de prendre pour elle un dernier époux royal. Elle choisit Klavo, un de ses propres descendant, pour être le père de la génération

suivante. Klavo fut retiré à son clan, interné à la cité royale et nourri de la jelikraton qui devait le préparer à l'accouplement.

Mais Klavo n'était pas un jawa comme les autres. Il était instruit, et en lui brûlait la flamme du Kekuwatan'kabeh Urip, connu dans toute la galaxie sous le nom de Force. Non seulement il ne désirait pas devenir un époux royal, mais il avait en tête de libérer son peuple de l'esclavage des insectoïdes, qui obligeaient les jawa à exploiter les minéraux nécessaires pour leurs moteurs hyperspatiaux.

Lorsqu'il s'en ouvrit à la Reine-mère, celle-ci entra en fureur et fit enfermer Klavo dans le cachot le plus profond de la cité royale, en attendant le moment du Pambuahan'pungkasan qui donnerait naissance à une nouvelle génération de jawas.

Klavo, utilisant ses capacités hors normes, s'évada, et s'enfuit au loin, le plus loin possible de la cité royale, afin d'échapper à l'ire de la reine-mère.



Il parcourut le désert de Tatoonie de long en large à la recherche d'un havre de paix. Le Kekuwatan'kabeh Urip le guidait dans ses pérégrinations, si bien qu'il finit, après des mois d'errance dans le désert aride, par arriver près d'une caverne. Là, l'attendait les trois Anciens, avertis de son arrivée par la Force. Ces trois anciens étaient des jawas, d'âge très avancé, vénérables, initiés

aux arcanes du Kekuwatan'kabeh Urip, qui leur avait révélé la venue prochaine d'un futur disciple. — Veux-tu devenir notre disciple ?

Demandèrent-ils à Klavo.

Après quelques minutes de réflexion, il demanda :

— Pourrai-je libérer le peuple jawa si je deviens votre disciple ?

— Rien ne te sera impossible, si tu deviens notre disciple. Le Kekuwatan'kabeh Urip te rendra fort, sage et avisé. Telle est sa volonté.

Fort de cette affirmation, Klavo accepta l'offre généreuse des Anciens. Il resta là, avec eux, de très nombreuses années, étudiant les pouvoirs de la Force, lisant les Livres sacrés des Anciens, et exerçant son pouvoir, qui devint de plus en plus grand.

Près de 40 ans après sa fuite de la cité royale, Klavo découvrit ce qu'il pensait être le moyen de libérer les jawas, de les faire quitter Tatoonie et peut-être même de les ramener sur le monde qui les avait vu naître. L'un des ouvrages secret des Ancien évoquait la possibilité, grâce à la Force, de briser le continuum, de créer une brèche dans l'espace et le temps, et d'ouvrir une porte vers un endroit appelé Nangendi'waeliya, un plan mystique contenant des chemins et des portes, entre le temps et l'espace, reliant entre eux tous les mondes et tous les moments. Klavo se sentait de taille à mener à bien le rituel, et à ouvrir une porte vers



cet ailleurs.

Mais les trois anciens l'avertirent :

— Prend garde à la présomption, ne te crois pas debout si tu n'es qu'à genoux. La sagesse est l'apanage des modestes. Seul de puissants maîtres du Kekuwatan'kabeh Urip ont réussi à entrer dans le Nangendi'waeliya, quand leur pouvoir, devenu trop grand, mettait en péril toute vie dans la galaxie.

— J'en suis capable, répondit Klavo. L'espace et le temps plieront sous mon pouvoir. C'est vous qui m'avez dit que rien ne me serait impossible.

Convaincu qu'il pourrait faire s'enfuir loin de Tatoonie tout le peuple jawa à travers la porte qu'il s'appropriait à ouvrir, Klavo entreprit le rituel, sous la surveillance des trois Anciens. Il concentra en lui bien plus de Force que jamais, et dans un fracas de tonnerre, il ouvrit une porte vers l'ailleurs, une petite porte, insuffisante pour faire passer tout son peuple, mais représentant un échantillon de ce qui lui était possible de faire sur une plus



plus grande échelle. La taille de la Porte n'était rien, elle ne dépendait pas de la puissance de celui qui l'ouvrait, simplement de sa volonté, et celle de Klavo était plus dure que le duracier. Mais Klavo, dans son orgueil, avait méconnu une partie des textes anciens, ceux qui faisaient référence aux forces du mal qui étaient tapies dans le Nangendi'waeliya, et qui n'attendaient qu'une ouverture pour s'introduire dans l'autre monde. Aussitôt la porte ouverte et stabilisée, deux grandes mains crochues jetant des éclairs bleus traversèrent l'horizon des événements, Klavo et les trois anciens furent balayés, jetés à terre par la puissance de celui que les livres nommaient Gustiireng, le seigneur noir du monde entre les mondes, bien décidé à profiter de ce passage pour entrer dans le nôtre. Klavo pris aussitôt conscience de son erreur. Il avait été présomptueux, il s'était cru debout, alors qu'il n'était qu'à genoux. Il lui fallait réparer, même si cela



devait lui coûter la vie.

— Je vais le repousser vers l'ailleurs, dit-il aux trois anciens, et vous, verrouillez la porte, bloquez-la pour l'éternité, soyez-en à la fois les gardiens et le verrou.

— Tu vas mourir ! Dirent les anciens, nul ne peut contenir le pouvoir déchaîné de Gustiireng !

— Sans doutes, répliqua Klavo, sans doutes vaut-il mieux que je meure pour prix de ma présomption, en retenant à jamais ce pouvoir hors de notre monde.

Et il se jeta à travers la Porte, repoussant de son pouvoir les forces du mal, qui le déchiraient vivant, vers l'intérieur, vers le Nangendi'waeliya.

Dès qu'il fut passé, les trois anciens entamèrent un rituel qui allait verrouiller la Porte. Ils devinrent eux-mêmes le verrou, chacun étant une des pièces de la combinaison qui maintenait fermée la Porte des Anciens. Elle est là jusqu'à ce jour, témoignage de l'adage suivant : la sagesse est l'apanage des modestes, mais la présomption, la fille de l'orgueil, mène au désastre.

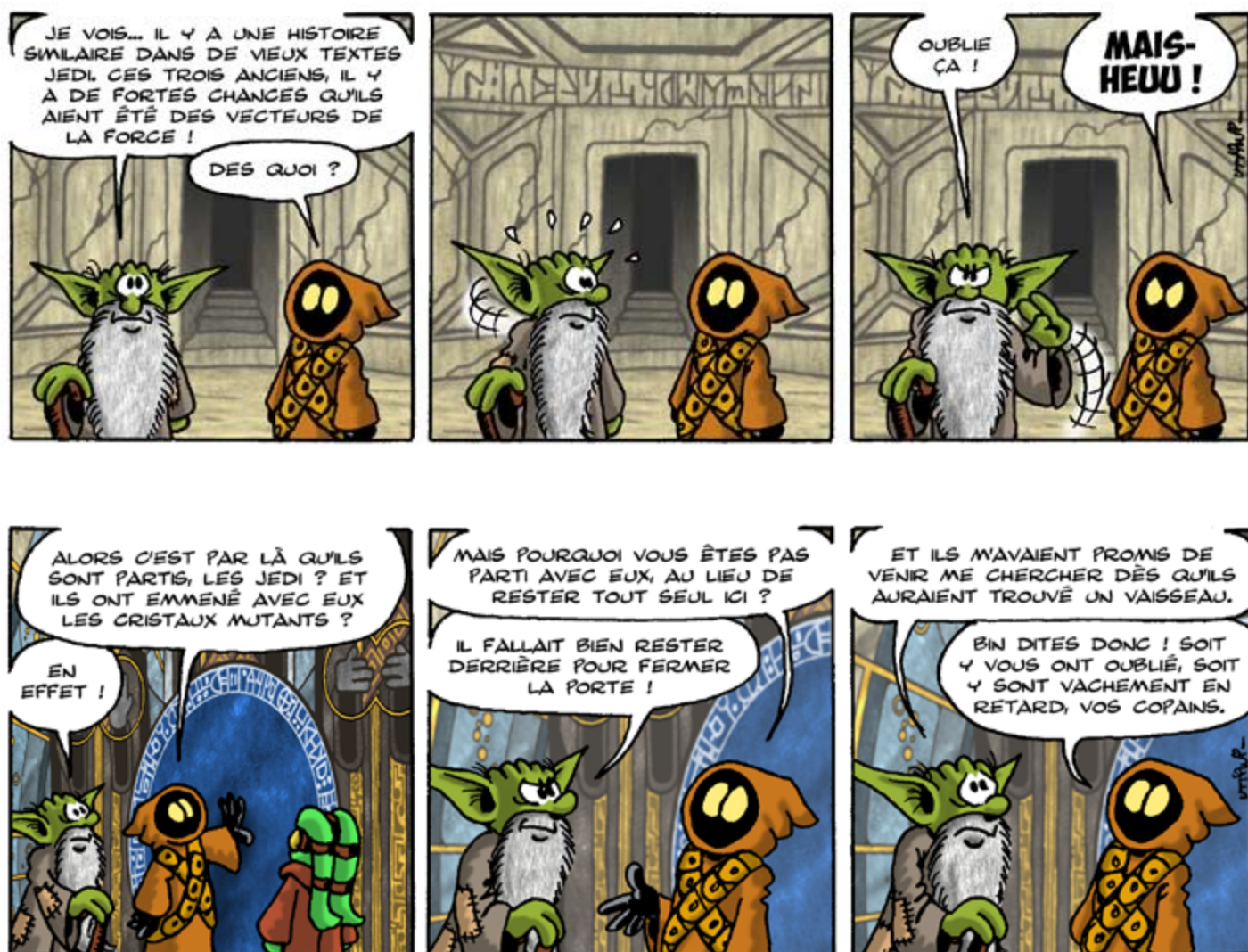





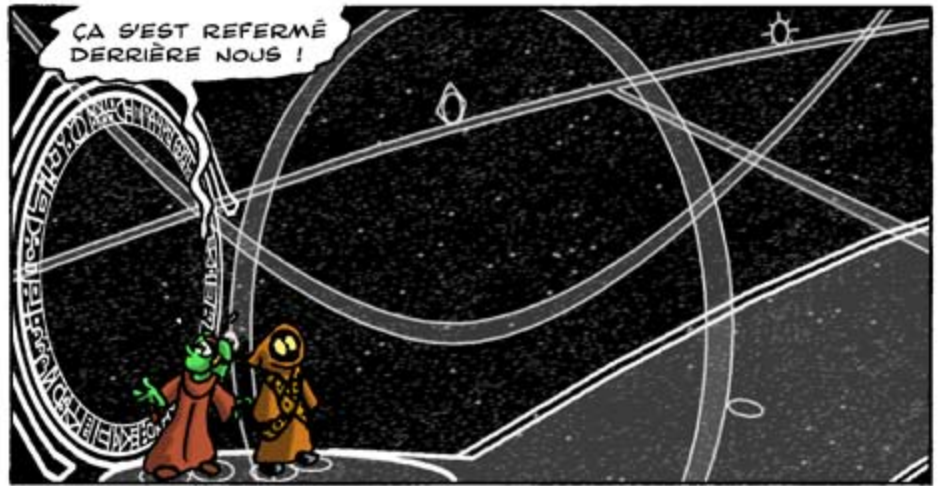











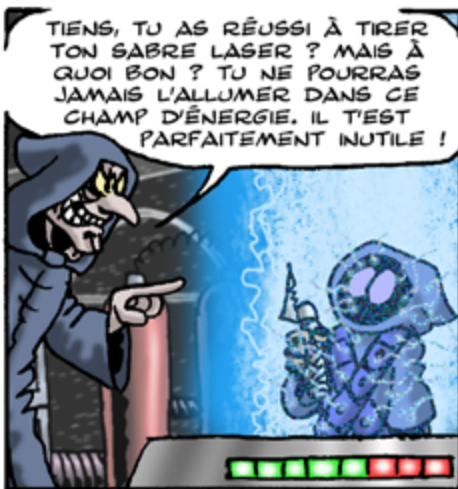

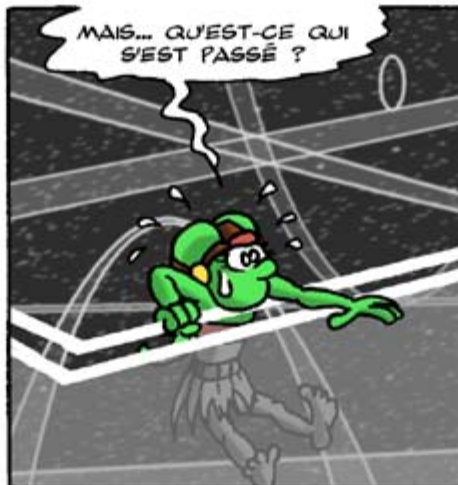



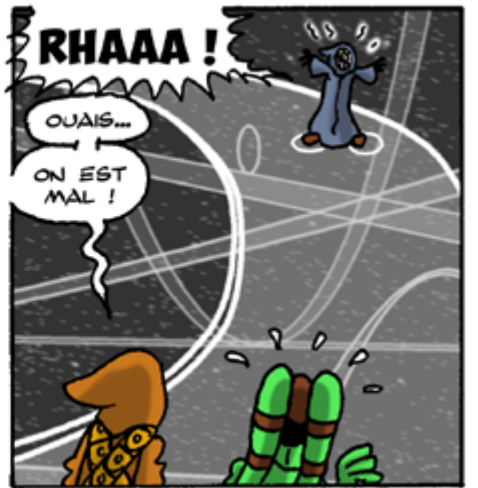



VITE ! REFERME !



WAOW ! TU AS RÉUSSI !

DIS DONC ! J'AI BIEN CRU QU'ON ÉTAIT CUIITS !

POUF !



QUELQU'UN VOUDRAIT BIEN M'EXPLIQUER CETTE COMÉDIE ?

RECTIFICATION : C'EST MAINTENANT QU'ON EST CUIITS !



CES ÉCLAIRS ! C'ÉTAIT QUOI ?

HA, ÇA ? LES FORCES DU MAL ! VOUS SAVEZ COMME DANS LA VIEILLE LÉGENDE JAWA ! MAIS RIEN DE DRAMATIQUE !



ON A GÉRÉ TOUT ÇA, HEIN, NAYRA ? PAS DE SOUCIS !

MAIS VOUS ÊTES RESTÉ LÀ-DÉDANS À PEINE DIX MINUTES !

HEU...



DIX MINUTES ? VOUS ÊTES SUR ? MAIS ÇA FAIT DES HEURES...

LE MIEUX SERAIT DE TOUT NOUS RACONTER DU DÉBUT !

HEUU... PAR QUOI JE COMMENCE ?



UN PEU PLUS TARD...

ET VOUS CROYEZ VRAIMENT QUE JE VAIS CROIRE UNE HISTOIRE AUSSI DÉMENTE ? VOUS ME PRENEZ POUR QUI ?

ET QU'EST-CE QUE C'EST QUE CETTE TENUE, PADAWAN ?



HÉ HO, UNE MINUTE ! MOI J'TE PERMETS PAS DE LUI CAUSER COMME ÇA ! ELLE M'A SAUVÉ LA VIE AU MOINS DEUX FOIS AUJOURD'HUI, ET ELLE A AFFRONTÉ TOUTE SEULE LE PUANT. C'EST SUPER COURAGEUX !



ET PIS POUR LA TENUE, JE TE FERAIS REMARQUER QU'AHSOKA ELLE ÉTAIT PAS BEAUCOUP PLUS HABILÉE QUE ÇA, AU DÉBUT.

ET ÇA DÉRANGEAIT PERSONNE. ALORS UN TON EN-DESSOUS AVEC NAYRA !



DES PORTES VERS D'AUTRES MONDES ET D'AUTRES ÉPOQUES, COMMENT VEUX-TU QU'ON CROIE UN TRUC PAREIL, ENFIN !



SI QUELQUE CHOSE DE CE GÉNRE EXISTAIT, TU CROIS QUE MOI, UN MAÎTRE JEDI, JE NE SÉRAIS PAS AU COURANT ?

COMME LES CRISTAUX MUTANTS ?



LES QUOI ?

QUAND JE TE LE DISAIS !





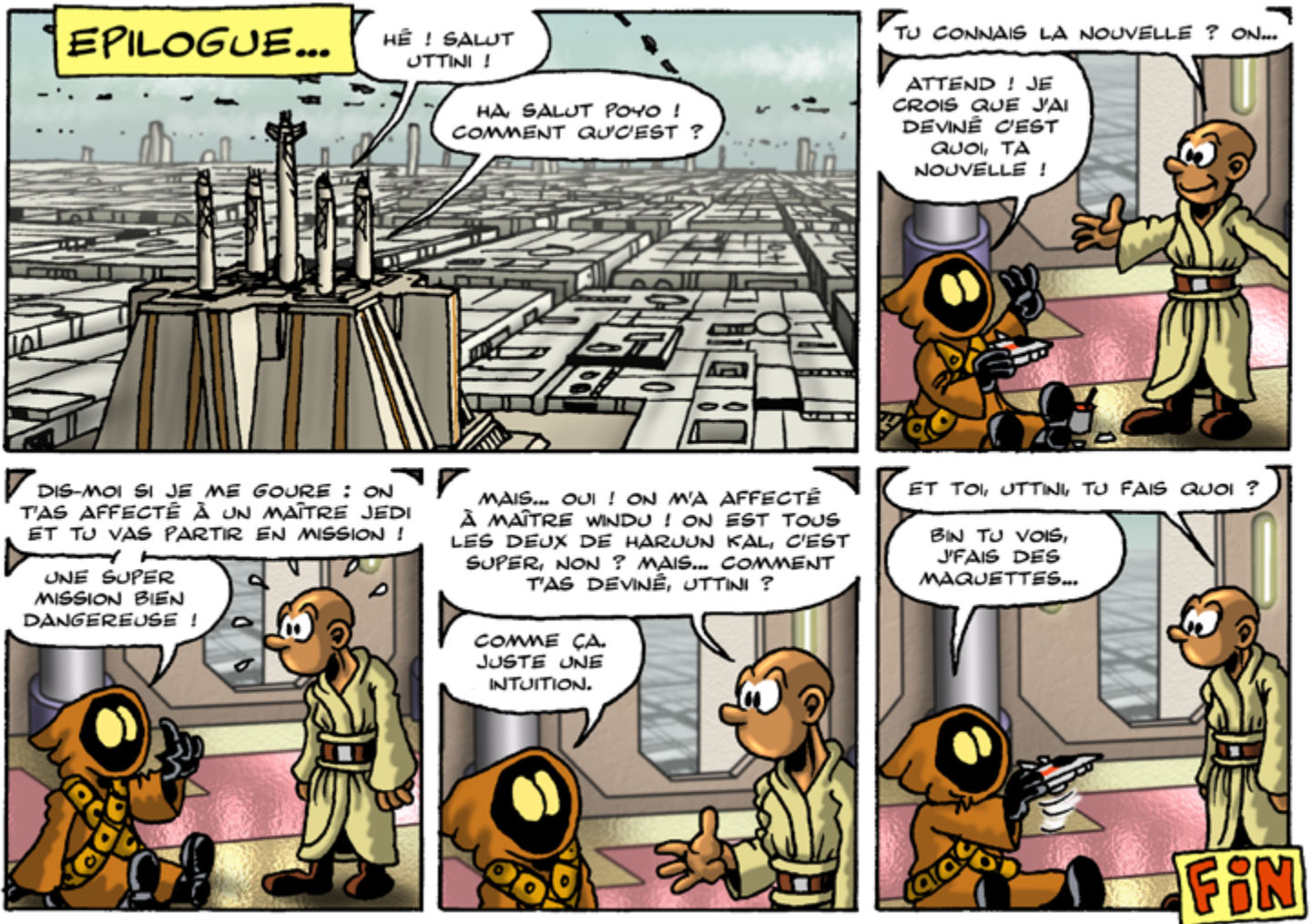

DE L'OPUS VII

## LES TEASERS DE L'OPUS VII







### La création du tank jawa.

Pour le tank jawa, j'avais au départ une idée assez confuse de ce que je voulais. Certainement pas un char conventionnel, avec une tourelle et un canon, non, il fallait quelque chose de moins agressif, de moins guerrier, et quelque chose de rustique et d'inhabituel, tout en restant plausible. Après plusieurs heures de recherches dans les tanks de la première guerre mondiale, je suis tombé sur



le char britannique Whippet mark V. Il avait globalement l'allure que je recherchais. Mais c'était une toute petite machine, transportant tant bien que mal deux personnes. Il me fallait quelque chose de plus imposant. Je me suis donc mis au travail, griffonnant des plans de char inspirés du Whippet.

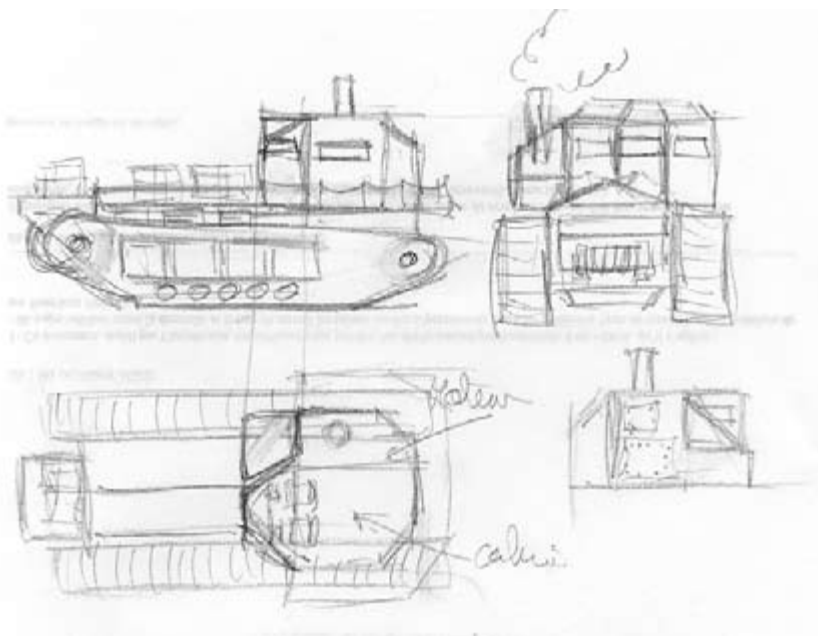

Le char jawa devait être un char d'exploration, pas de guerre. Donc pas question de lui faire des canons, des mitrailleuses, ou quoi que ce soit du genre. Il était bien plus dans l'optique du char lunaire de Tintin dans «On A Marché Sur La Lune». je lui empruntai même la couleur orange (qui est aussi celle des Sandcrawlers jawa).

Un détour par mon logiciel de modélisation 3D préféré, quelques heures de galère pour gérer certains volumes, et le tour est joué ! Je n'ai eu qu'à modéliser ensuite l'intérieur pour faire tenir toutes les scènes concernant le char, à ajouter quelques babioles, des caisses arimées sur le dessus, et le char de prospection jawa est né. Il est évidemment bien plus grand que le Whippet d'origine, et nettement moins agressif. Qu'en dites-vous ?

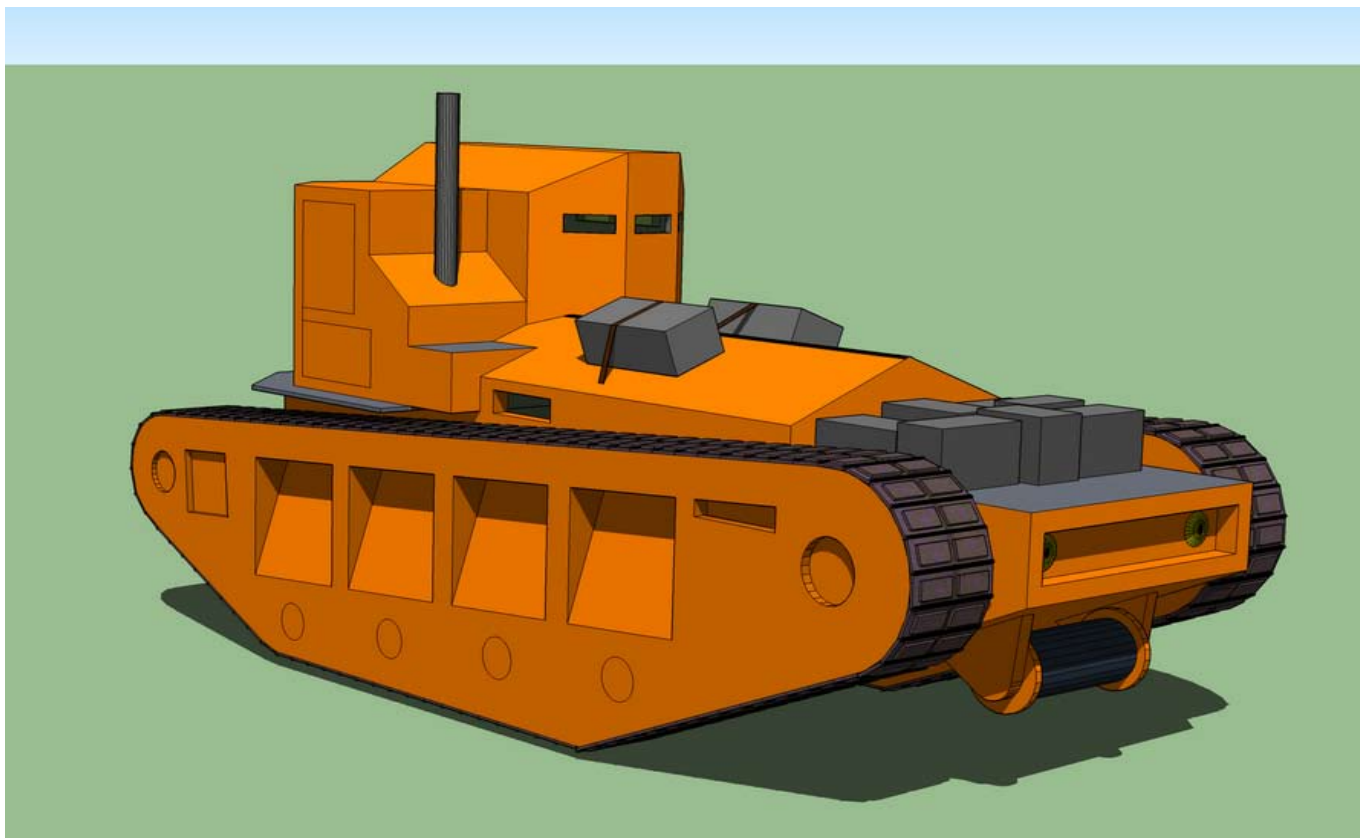

Rendez-vous très bientôt pour la suite de notre aventure dans Je Veux Être Un Jedi Opus VIII !

# LES PETITS DESSINS DE SOL

QUELQUES STRIPS "PIRATES" RÉALISÉS PAR SOL, ET UN DESSIN POUR L'ANNIVERSAIRE DE LA SÉRIE.



les (més)aventures du Tini !

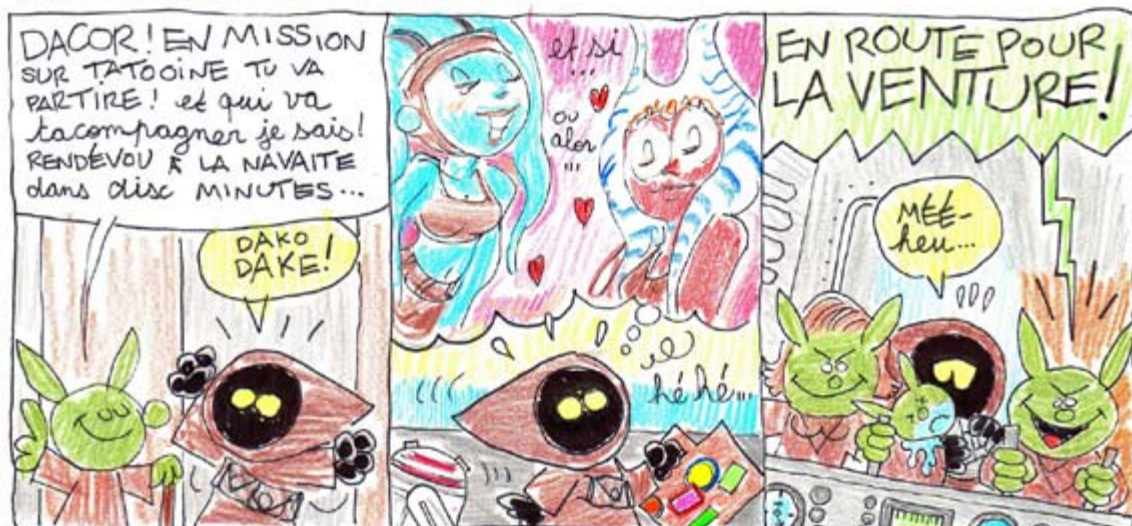

Utkini  
le JAWA



utkini le Jawa



utkini le Jawa



utkini le Jawa



utkini

A LA QUESTION "COMMENT LES JAWAS FABRIQUENT LEUR PEINTURE ORANGE", RÉPONSE ÉCLAIRÉE DE MAÎTRE SAM, UN PERSONNAGE QUE J'AI RÉCUPÉRÉ DANS UNE DE MES ANCIENNES SÉRIES DE BD DE L'ÉPOQUE DU LYCÉE.

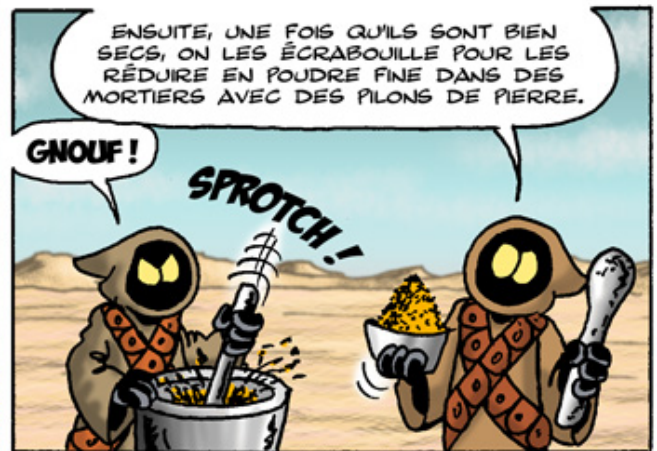

DU MÊME AUTEUR :

- JE VEUX ÊTRE UN JEDI OPUS I À VI
- STAR WARS ÉPISODE IV - UN NOUVEL ESPOIR
- THE FORCE UTTINISHED
- DOUBLE PIÈGE !
- LA CLÉ LAXIENNE
- THE PLANET KILLERS VOL I

EN COLLABORATION AVEC LAMB BEAR :

- STAR WARS EPISODE I - LA MENACE FANTÔME

VENEZ LIRE DES GAGS INÉDITS SUR  
[WWW.STARWARS-UNIVERSE.COM](http://WWW.STARWARS-UNIVERSE.COM) !  
ET REJOIGNEZ-NOUS SUR LE  
FORUM STARWARS-UNIVERSE !

